



BACnet / Modbus WALL PLATE SERIES

Installation & Operation Instructions

Phone: 1-888-967-5224

Website: workaci.com

GENERAL INFORMATION

The BACnet MS/TP / Modbus RTU Wall Plate Series sensor is designed for use with electronic controllers in commercial heating and cooling building management systems. The ACI BACnet MS/TP / Modbus RTU Wall Plate Series sensor can be ordered to monitor temperature, RH, or temp/RH in commercial applications. It uses BACnet MS/TP or Modbus RTU for physical connection to a BAS or controller, has dip switches to set addresses and baud rate, parity and stop bits (Modbus RTU only) and has on board end-of-line termination. There is no analog output.

For optimal readings, follow these tips:

- Do not install on external walls.
- Do not install near heat sources. eg: lamps, radiators, direct sunlight, copiers, chimney walls, walls concealing hot-water pipes.
- Avoid air registers, diffusers, vents, and windows.
- Avoid confined areas such as shelves, closed cabinets, closets, and behind curtains.
- Eliminate and seal all wall and conduit penetrations. Air migration from wall cavities may alter temperature readings.

WIRING INSTRUCTIONS

The BACnet/Modbus Wall Plate Series temperature sensor has a depluggable terminal block located on the front of the PCB. For ease of wiring, we recommend removing the block, wiring, and reattaching before mounting. 16 to 22 AWG two conductor shielded cable is recommended for powering the sensors.

ACI recommends using Belden 3105 or compatible cable for RS-485 communication wiring. This wire has 120 ohm input impedance. The terminal blocks allow for (1) or (2) wires to be connected in each position for daisy chaining. Daisy chain the RS-485 wiring and do not use "Star" or "T" wiring. Avoid running communication wires next to AC line voltage wires. These can be sources of noise that can affect signal quality.

FIGURE 1: ENCLOSURE DIMENSIONS

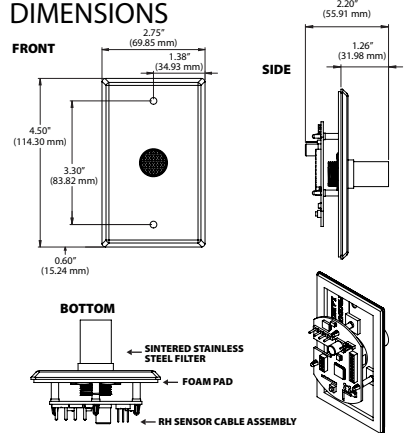

*Sintered filter and cover is for RH units only

FIGURE 2: MOUNTED ASSEMBLY

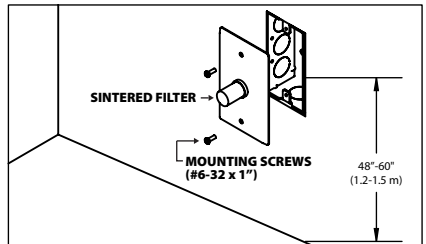
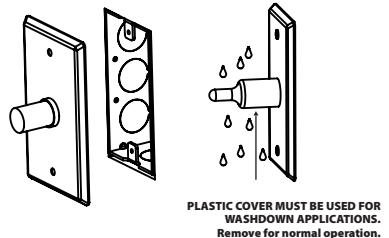

FIGURE 3: SINTERED FILTER COVER



*Sintered filter and cover is for RH units only



PRECAUTIONS

- Remove power before wiring. Never connect or disconnect wiring with power applied.

- It is recommended you use an isolated UL-listed class 2 transformer when powering the unit with 24 VAC. Failure to wire the devices with the correct polarity when sharing transformers may result in damage to any device powered by the shared transformer.

- DO NOT RUN THE WIRING IN ANY CONDUIT WITH LINE VOLTAGE (24/120/230 VAC).

- If the 24 VDC or 24VAC power is shared with devices that have coils such as relays, solenoids, or other inductors, each coil must have an MOV, DC/AC Transorb, Transient Voltage Suppressor (ACI Part: 142583), or diode placed across the coil or inductor. The cathode, or banded side of the DC Transorb or diode, connects to the positive side of the power supply. Without these snubbers, coils produce very large voltage spikes when de-energizing that can cause malfunction or destruction of electronic circuits.

FIGURE 4: LAYOUT

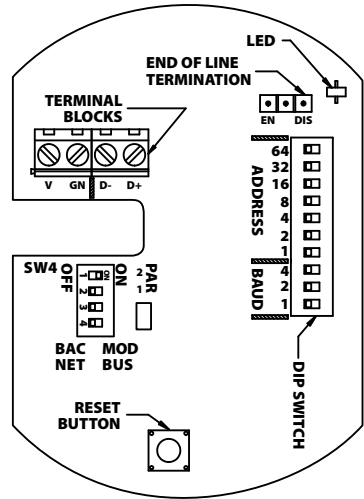

TABLE 1: WIRING CONNECTIONS

TERMINAL BLOCKS	CONNECTIONS
+V	Power Supply Positive 8-34VDC / 10-28VAC
GN	Power Supply Common or Ground
D-	EIA-485 Data Negative
D+	EIA-485 Data Positive

MOUNTING INSTRUCTIONS

Take care when mounting. Check local code for mounting height requirements. Typical mounting heights are 48-60" (1.2 - 1.5 m) off the ground and at least 1.5' (0.5 m) from the adjacent wall. The sensor should be mounted in an area where air circulation is well mixed and not blocked by obstructions.

RH Wall Plates include a Black Rubber Cap that fits over the sensor filter. This cap should be placed on the sensor filter during wet/wash down processes. **The cap must be removed for normal operation.** Plate temperature sensors (optional) are mounted on the back of a 1 Gang stainless steel plate. The foam pad will insulate the sensor from any drafts in the wall. There are (2) 6-32 x 3/4" machine screws provided for junction box mounting. Remove plastic film off stainless steel cover.

BACnet MS/TP and Modbus RTU INTERFACE

The BACnet Master-Slave/Token-Passing (MS/TP) and Modbus Remote Terminal Unit (RTU) data link protocol uses EIA-485 as a two-wire, daisy chain network. A branch is a discrete chain of devices connected to a controller. The max number of devices per segment is 32, as per the BACnet and Modbus specifications. 4000 ft (1219.2 m) is the maximum recommended length for a segment, which includes all devices from the controller to the last device in the daisy chain.

BACnet or Modbus RTU protocol selection is done via SW4 switch. Place dipswitch #4 to the OFF position for BACnet and the ON position for Modbus. Refer to **FIGURE 5 (P.3)**.

BACnet MS/TP and Modbus RTU INTERFACE (Continued)

ACI's BACnet sensors are master devices. Only master nodes are allowed to send and receive tokens on the MSTP network.

ACI's Modbus RTU sensors are slave devices. Only one master is connected to the bus and several slave nodes are connected to the same trunk. The Master initiates communication. The slave nodes only respond to a request from the Master. Slave nodes do not communicate with each other.

Each branch must have all devices connected with (+) connected to (+) and (-) connected to (-). If a shielded cable is used, this is not to be connected to the devices. The shield cable should only be connected on one end to earth ground, usually at the controller. The start and end of each branch should have a termination resistor at the device level or at the controller.

Each device must be configured for the correct baud rate and have a unique address in each branch. The baud rate for the branch is set by the controller. This product has auto-baud for ease of network configuration but setting the baud rate using the DIP switches is recommended. **Note:** Auto-baud feature does not function when Modbus is the selected protocol.

BAUD RATE SELECTION

By default, BACnet Protocol and Auto-Baud is factory set. If the sensor is field adjusted for Modbus RTU, the baud rate should be selected at this time to match the Master configuration. If Modbus RTU protocol is selected it is recommended the sensor unique address is selected at this time. Switches 8-10 are used to set the BACnet and Modbus baud rate. Refer to **TABLE 2** for switch settings. Where (0) is OFF and (1) is ON. If the system's baud rate is known, it is recommended to set the specific baud rate to match the system. **If the device is powered when a change is made, the device must be power cycled or reset for changes in baud rate to be made.**

TABLE 2: BAUD RATE SELECTION

BAUD RATE	SW 8	SW 9	SW 10
Auto-Baud	0	0	0
9600	0	0	1
19200	0	1	0
38400	0	1	1
57600	1	0	0
76800	1	0	1
Reserved	1	1	0

****Note: Auto-Baud not available for Modbus RTU.**

FIGURE 5: SW4 DIPSWITCH SETTINGS



- DIP 1 – PAR2 (only applies to Modbus)**
- DIP 2 – PAR1 (only applies to Modbus)**
- DIP 3 – OPEN (For Future Use)**
- DIP 4 -- OFF is BACNET, ON is MODBUS**

EOL TERMINATION RESISTANCE SELECTION

RS-485 requires that the last device in a chain have a termination resistor. This is controlled using a jumper in the EN (enabled) position marked on **FIGURE 6**. When the jumper is set to EN (enabled), a 120Ω resistance is added in parallel to the data line. When the jumper is set to DIS (disable), the resistance is not added. By default, the jumper is placed in the DIS (disabled) position.

FIGURE 6: EOL TERMINATION JUMPERS

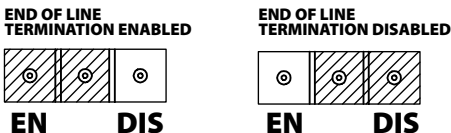

RESET

The reset button can be used to reset the device without disconnecting power. The location of this button is shown in **FIGURE 4 (P.2)**.

LED INFORMATION

One LED indicates four statuses. Solid green shows that power is good, but no data is transmitting. A solid Amber indicates that auto-baud is set and no data has been received to set a baud rate. Green/Amber flashing indicates data is being transmitted or received. Solid Red LED status indicates an error state, usually loss of communication on the network. If BACnet is the selected protocol, and this status remains for 10 times the APDU timeout, the device will automatically reset. If this state remains longer than that, reset the device.

ADDRESS SELECTION

Switches 1-7 are used to set the BACnet and Modbus addressing. Refer to **TABLE 3** for switch settings. Each device in a network branch must have a unique address. The value of each position is printed on the board. By default, the address is (0). **Note: (0) cannot be used if Modbus RTU protocol is selected and will require a unique address.** If the device is powered when a change is made, the device must be power cycled or reset for changes in address to be made.

TABLE 3: ADDRESS SELECTION

ADDRESS	SW 1 (64)	SW 2 (32)	SW 3 (16)	SW 4 (8)	SW 5 (4)	SW 6 (2)	SW 7 (1)
0	0	0	0	0	0	0	0
1	0	0	0	0	0	0	1
12	0	0	0	1	1	0	0

DEVICE CONFIGURATION THROUGH BACnet

DEVICE INSTANCE

The Device Instance, by default, is 1035000 plus the Address. For example, an Address of 21 results in a default address of 1035021. This can be changed once the device is connected to the network, but each device instance must be unique within the network, not just this segment.

DEVICE NAME

By default, the device name is based on the type of device and the address. The device name can be a character string up to (32) characters in length. This can be changed once the device is connected to the network. For example: Temperature Sensor - 034. The device name must be unique throughout the entire BACnet network, not just this segment.

TEST MODE BACnet

For the Sensor objects (AI0 and AI1), a test mode can be set by writing the Boolean value true to the "out-of-service" property. Then the present-value can be set to any valid test value the user requires. This allows a user to test reactions to specific values returned by this device.

DEVICE LOCATION

The device location is optional but is intended to allow for further definition of the device's location. The device location can be a character string up to 64 characters in length.

DEVICE DESCRIPTION

By default, the device description is optional but is intended to allow for further information about the device or its environment. The device location can be a character string up to 64 characters in length.

TEMPERATURE UNITS CONFIGURATION

For temperature, the units of measure can be configured using BACnet. By writing to the units property of the temperature sensor (AI0), the reported temperature units can be changed. **TABLE 4** shows the values to write.

TABLE 4: UNIT SETTING

UNITS	VALUE
°F	64
K	63
°C	62

TEMPERATURE AND RH OFFSET

This device allows for a temperature offset of +/-5C (9F) and an RH offset of +/-10%. By default, these values are set to 0, meaning no offset is added.

These are set by writing to the present value of the Temperature Calibration Offset (AV0) or RH Calibration Offset (AV1). The value written must be within the specified range or an error will be returned. To set back to factory settings, write any changed values to 0.

TABLE 5: BACnet OBJECT TABLE

OBJECT TYPE	OBJECT ID	OBJECT NAME	RANGE	BACnet ENGINEERING UNITS	PIC STATEMENT QR
Device	-----	BN11x0	0-4194302	-----	
Analogue	AI-0	Temperature Sensor	34.7 - 122.0	degrees-Fahrenheit (64) - default	
Inputs	AI-1	RH Sensor	0.0 - 95.0	percent-relative-humidity (29)	
Analogue	AV-0	Temperature	-9.0 - 9.0	delta-degrees-Fahrenheit (120)	
Values	AV-1	RH Calibration Offset	-10.0 - 10.0	percent-relative-humidity (29)	

Note: The table shows all objects for Temperature and RH. If you have a Temperature only model, the RH objects (AI-1 and AV-1) will not be present. If you have a RH only model, the Temperature objects (AI-0 and AV-0) will not be present.

DEVICE CONFIGURATION THROUGH MODBUS RTU

MODBUS RTU DATABITS, PARITY, AND STOP BITS SELECTION

Confirm Modbus Protocol is selected via dipswitch #4 on SW4 - see **FIGURE 5**. The device that requests information is called the Modbus Master and the devices giving the information are Modbus Slaves. The Modbus sensors are slave devices and the number of Data Bits needs to be the same as in the Master device configuration. ACI's Modbus RTU sensors utilize 8 data bits during communication exchange.

Parity and stop bit selection is performed via the SW4 switch located on the board. Dipswitches #1 and #2 are adjusted to select the Parity and stop

TABLE 6: PARITY AND STOP BITS

PAR 2	PAR 1	Mode (Databits-Parity-Stop Bits)
0	0	8-Even-1
0	1	8-Odd-1
1	0	8-None-2
1	1	8-None-1 (Non-Standard)

bits - see **TABLE 6**. Where (0) is OFF and (1) is ON. If BACnet protocol is selected these dipswitches are irrelevant.

TEST MODE Modbus RTU

There are 5 data values in test mode. Coil 1001, Holding Registers (HR) 1001 and 1002, and the Input Registers (IR) 0003 and 0004 for Temp and RH values. When Coil 1001 is enabled, reading IR 0003 and 0004 will respond with the values in HR 1001 and 1002, other wise they will respond with the actual sensor values. General process for this is to write initial test values to HR 1001 and 1002, Enable Coil 1001 and then read as normal from IR 0003 and 0004. While Coil 1001 is enable, it is possible to write a change of value to IR 1001 and 1002, which will be reflected in the next read from IR 0003 and 0004. When testing completed, disable Coil 1001. The status of Coil 1001 and HR 1001 and 1002 are not persistent between reset/power cycle.

MODBUS RTU MODEL

Modbus data model:

Four (4) primary data tables (addressable registers)

- Discrete Input (read only bit).
- Coil (read / write bit).
- Input register (read only 16 bit word, interpretation is up to application).
- Holding register (read / write 16 bit word).

MODBUS RTU MAP

REFERENCE	ADDRESS	NAME	DESCRIPTION
COILS (CL)			
1001	1000	Test Mode Enable	0 = Disable Test Mode. IR3 and IR4 will read with current Sensor Value. 1 = Enable Test Mode. IR3 and IR4 will read with the values stored in HR1001 and HR1002 .
INPUT REGISTER (IR)			
1	0	Sensors Present	For each bit location: 0 = Sensor not present 1 = Sensor present Bit 0 - Temperature Sensor Bit 1 - RH sensor
2	1	Reserved	N/A
3	2	Temperature Sensor Value	For example, a value of 312 would represent 31.2 Degrees of the units selected in HR1. Signed Integer.
4	3	RH Sensor Value	For Example: A value of 429 would represent 42.9% Relative Humidity.
2001	2000	Temperature Range Min	Temperature range Minimum value (Tenths). Signed Integer.
2002	2001	Temperature Range Max	Temperature range Maximum value (Tenths). Signed Integer.
2003	2002	RH Range Min	Relative Humidity range Minimum value (Tenths)
2004	2003	RH Range Max	Relative Humidity range Maximum value (Tenths)
9001	9000	Unsigned Integer Test Value	Always reads a value of 54321. For testing proper communication and interpretation of values.
9002	9001	Signed Integer Test Value	Always reads a value of -12345. For testing proper communication and interpretation of values.
9003 Thru 9006	9002 Thru 9005	Test String Test Value	Always reads a string value of "-123.45" (Null terminated). For testing proper communication and interpretation of values.
9007 Thru 9010	9006 Thru 9009	Serial Number	Non-null terminated character string of the Serial Number. For example, "12345678"
9011 Thru 9016	9010 Thru 9015	Firmware Version	Non-null terminated character string of the Firmware Version. For example, "02.00.000.90"
HOLDING REGISTER (HR)			
1	0	Temperature Units	Value - Units: 62 - Degrees Celsius 63 - Degrees Kelvin 64 - Degrees Fahrenheit



HOLDING REGISTER (HR)			
2	1	Temperature Offset Value	Temperature Offset Value (Tenths) Signed Integer. User can set an offset that will be added to Temperature sensor and reflected in IR3. Range of -5.0 to 5.0 degrees Celsius/degrees Kelvin (-9.0 to 9.0 degrees Fahrenheit). For example, writing -16 would add an offset of -1.6 degrees.
3	2	RH Offset Value	Relative Humidity Offset (Tenths) User can set an offset that will be added to RH sensor and reflected in IR4. Range of -10.0 to 10.0 %RH. For example, writing -16 would add an offset of -1.6 %RH.
1001	1000	Test Mode Temperature Value	User can set what temperature value (Tenths) that would be returned when reading IR3 and Test Mode is Enabled in CL1001. For Example -400 would be -40.0.
1002	1001	Test Mode RH Value	User can set what RH value (Tenths) that would be returned when reading IR4 and Test Mode is Enabled in CL1001.
9001 Thru 9016	9000 Thru 9015	Device Name	Device Name, Device Location, and Device Description are user settable character strings (Null terminated) that can be used to allow for system customization and device identification.
9017 Thru 9048	9016 Thru 9047	Device Location	For example: Device Name (Modbus 9001 thru 9016) could be set to a system ID: "S2253"
9049 Thru 9080	9048 Thru 9079	Device Description	Device Location (Modbus 9017 thru 9048) could be set to: "Building 5, Floor 2, Duct 3" Device Description (Modbus 9049 thru 9080) could be set to: "Cold air return sensor"

WARRANTY

The ACI BACnet and Modbus RTU Wall Plate Series RH sensors are covered by ACI's Five (5) Year Limited Warranty, which is located in the front of ACI'S SENSORS & TRANSMITTERS CATALOG or can be found on ACI's web site: www.workaci.com.

W.E.E.E. DIRECTIVE

At the end of their useful life the packaging and product should be disposed of via a suitable recycling centre. Do not dispose of with household waste. Do not burn.

NOTES

PRODUCT SPECIFICATIONS

Supply Voltage:	12 to 36 VDC / 24 VAC +/- 10%, 50/60 Hz (Reverse Polarity Protected)
Current Consumption:	25 mA maximum (0.67 VA)
Number Temperature Sensing Points:	One
Operating Temperature Range:	
Transmitter:	-22 to 176°F (-30 to 80°C)
Sensor (Temp-Only):	-40 to 302°F (-40 to 150°C)
Sensor (RH and Temp/RH):	-40 to 176°F (-40 to 80°C)
Temperature Measurement Accuracy:	@ 77°F (25°C): +/- 1.0°F (+/- 0.5°C)
Temperature Calibration Offset:	+/- 9°F (+/- 5°C) (Field Configurable)
Number RH Sensing Points:	One
RH Measurement Range:	0 to 100%
RH Measurement Accuracy:	@ 77°F (25°C): +/- 2% from 10 to 90% RH
RH Calibration Offset:	+/- 10% RH (Field Configurable)
Temperature / RH Update Rate:	4 seconds
Communication Protocol:	BACnet MS/TP or Modbus RTU = Field Selectable; EIA RS-485
Sensor Addresses:	0 to 127 (0 (Default - Must be changed if Modbus RTU is selected protocol); Field Selectable)
Supported Baud Rates:	Auto Baud (Default, BACnet Only), 9600, 19200, 38400, 57600, 76800, 115200 (Field Selectable)
Device Instance Number:	1035000 + Address (example: Address 127 = 1035127; Field Configurable)
Parity (Modbus RTU)	None/Even/Odd = Field Selectable
Stop Bits (Modbus RTU)	1 or 2 = Field Selectable
Databits (Modbus RTU)	8
Connections / Wire Size:	Screw Terminal Blocks / 16 AWG (1.31 mm ²) to 22 AWG (0.33 mm ²)
Terminal Block Torque Rating:	0.45 lbf-in (0.5 Nm) nominal
Storage Temperature Range:	-40 to 185°F (-40 to 85°C)
Operating Humidity Range:	10 to 95% RH, non-condensing
Sensing Probe & Filter Material:	304 Stainless Steel Diameter: 0.750" (19.05 mm)
Foam Pad Material / Flammability:	Neoprene/EPDM/SBR Polymer / UL94-HBF; FMVSS-302; MIL-R-6130C
Wall Plate Material:	430 Stainless Steel (Brushed Stainless Steel Finish)
Foam Material Foam Thickness:	Cross-linked LPDE (White) 0.25" (6.35 mm)



BACnet is a registered trademark of ASHRAE. ASHRAE does not endorse, approve or test products for compliance with ASHRAE standards. Compliance of listed products to the requirements of ASHRAE Standard 135 is the responsibility of BACnet International (BI). BTL is a registered trademark of BACnet International.

