



Automation
Components
Inc.

Q-CONTROLLER MONITOR AND CONTROL SYSTEM



INSTALLATION OPERATION AND MAINTENANCE MANUAL

AUTOMATION COMPONENTS, INC.
2305 PLEASANT VIEW ROAD | MIDDLETON, WI 53562
PHONE: (888) 967-5224 FAX: (608) 831-7407
Web: workaci.com

TABLE OF CONTENTS

1	GLOSSARY	3
2	GENERAL SYSTEM OVERVIEW.....	5
3	Q-CONTROLLER SPECIFICATIONS.....	6
4	Q-CONTROLLER INSTALLATION.....	9
4.1	TYPE AND LOCATION	9
4.2	METHOD.....	9
4.3	POSITIONING.....	9
4.4	CABLING.....	9
4.5	CONNECTORS	9
4.6	MOUNT INSTALLATION	10
4.7	POWER REQUIREMENTS	10
4.8	RS-485 INSTALLATION.....	12
5	Q-CONTROLLER FUNCTIONS.....	15
5.1	INITIAL STARTUP.....	15
5.2	SYSTEM SETTINGS.....	16
5.2.1	<i>System Options</i>	16
5.2.2	<i>Display Options</i>	20
5.2.3	<i>Other System Settings</i>	21
5.3	SETUP DEVICES	24
5.3.1	<i>Name Devices and Addressing</i>	24
5.3.2	<i>Auto Scan & Config</i>	25
5.3.3	<i>Cal 4-20mA Input for AI-Box</i>	25
5.3.4	<i>Cal 4-20mA Output for AO-Box</i>	26
5.3.5	<i>Switch Input Setup</i>	28
5.3.6	<i>Sensor Setup</i>	30
5.3.7	<i>AI (Analog Input) Setup</i>	32
5.3.8	<i>Scheduler Setup</i>	33
5.3.9	<i>Relay Setup</i>	34
5.3.10	<i>Buzzer/Strobe/Horn Setup</i>	37
5.3.11	<i>AO (Analog Output) Setup</i>	39
5.4	MODULE ADDRESS SETTING	40
5.5	MONITORING MODE.....	43
5.6	TESTING MODE	44
5.7	DATALOGGING MODE	45
5.7.1	<i>View Datalog in Table</i>	45
5.7.2	<i>View Sensor and AI in Graphic Drawing</i>	46
5.7.3	<i>View Event Log in Table</i>	46
6	MODBUS PROTOCOL SUPPORTED BY Q-CONTROLLER.....	47
7	TROUBLESHOOTING HINTS.....	47
	WARRANTY STATEMENT	48

1 Glossary

Actuate/De-Actuate: These terms are used instead of ‘make’ and ‘break’ to allow us to distinguish between performing an action due to an environmental condition and whether the contact may be closed (‘made’) or open (‘break’) because of our use of double throw contacts, and the option of normally energized relays.

Averaging: When setting alarms, the alarm can be set to operate on the basis of the average signal assigned to that relay.

Baud rate: A measure of the speed at which data is transferred over a digital communication link. Given as bit per second (bps). Generally the lower the speed, the more reliable.

bps: See Baud rate

Configuration Database: System configuration requires entering a great deal of information concerning relay operation, sensor type and so on.

Dry Contacts: The relay contacts are supplied without power applied to any output terminal.

Normally Energized: The relay coil is energized in the non-alarm state. This is sometimes referred to as ‘fail-safe’ because in the case of controller failure or loss of power, the relay contacts will open.

Normally Open Contacts: In the non-alarm state, but under power, the contacts are open.

Latching: A relay once actuated remains actuated even though the condition has been removed. Requires a manual operation to reset.

Protocol: The actual language of communication between devices, as distinguished from the electrical standard.

RS-485 (properly EIA-485): A wiring and electrical standard for digital communication in a multi drop environment. It is a 2-wire system, with a differential signal allowing relative immunity to variations in grounds between devices. RS-485: maximum 32 transceivers per loop, 4000 ft (1300 meters) max. 120 ohm line termination required. (Line termination resistors are available on all ACI devices via selectable jumpers).

Stub: A short wiring link branching from the main line.

Voting: When more than one sensor and setpoint is assigned to a relay, then voting defines how many must reach the setpoint before the relay actuates.

Window: When we want the relay to actuate between two setpoints, e.g. with setpoints at 50 and 100, the fan will operate only between 50 and 100. Not a feature of Q-Controller.

2 General System Overview

ACI gas monitoring system is a set of remote sensors, switch input, 4-20mA analog input, 4-20mA analog output and relay control modules tied together and controlled by the Q-Controller. ACI sensor/transmitters comprise a group of remote mountable sensors complete with electronics, most of which have both analog and digital communications, and most of which have LCD display and onboard relay.

The Q-Controller is a flexible programmable controller with capability to work with up to 128 digital sensor/transmitters, up to 128 4-20mA analog input signals and up to 128 switch input signals. With four on-board relays, the controller can also direct up to 128 relay outputs and 128 analog outputs.

The Q-Controller equips 6x RS-485 serial ports to communicate with remote devices.

- 4x RS-485 ports for ACI remote digital sensors/transmitters and modules
- 1x RS-485 ports with Modbus RTU slave protocol for BAS or SCADA
- 1x RS-485 port for ACI BACnet/IP module BAC-Box.

With the four RS-485 sensor ports, the controller can communicate with M-Series digital sensors and Q-Series digital sensors, as well as Q-Series Modules.

- Module AI-Box supports 8 channel 4-20mA analog inputs.
- Module AO-Box supports 8 channel 4-20mA analog outputs.
- Module BI-Box supports 4 channel switch input (Binary Input).
- Module BO-Box supports 4 channel relay outputs (Binary Output).

The Q-Controller config 4 switch inputs and 4 relay outputs onboard, if more inputs and outputs are needed in a system, the corresponding modules will be installed and connected to the one or all of the four sensor ports along with the digital sensors. The Q-Controller is able to work with up to 16x AI-Box, 16x AO-Box, 31x BI-Box and 31x BO-Box and 128 digital sensors.

The Q-Controller is a powerful 128 channel digital sensor data logger, 128 channel AI data logger, 128 channel BI data logger, 128 channel AO data logger and 128 channel Relay (BO) data logger. Event logging is also supported for all AO and relay outputs action.

Additional features include relay outputs for strobe light, horn and on-board Buzzer, Wi-Fi for wireless monitoring and configurations, 7 inch LCD touch screen for display and setup on-site.

Power supply is designed for 24VAC or 24VDC input power. ACI can supply a transformer for external mounting sized to the application if requested.

3 Q-Controller Specifications

NOTICE: Installing or using this equipment in a manner not specified by the manufacturer could cause electric shock, bodily injury, or risk of fire.

Specification:	
Power Supply	<p>Voltage: 24VDC nominal, range 18 to 30VDC 24VAC nominal, range 15 to 24VAC 50/60HZ</p> <p>Note: Input Power is half-wave rectifier circuit, it can be either floating or grounded. You will damage devices if you mix half wave and full wave rectifiers on the same AC source. Use extreme caution when sharing a common AC source. Sharing a common DC source is less problematic.</p> <p>Current: Q-Controller: max. 0.75 A (fuse protected) Strobe & Horn: max. 0.75 A (fuse protected)</p> <p>Total actual power is dependent on the system design. The power may be supplied to sensors and modules or each may have separate power supplies. Each type of sensor varies in its power requirements.</p> <p>Note: No external over-current protection is required. Over-current protection is provided by means of fuses F1 and F2. See fuse specification below.</p>
Fuse	<p>F1, F2 on Main Board: Polyswitch 750mA Polyswitch device resets after the fault is cleared and power to the circuit is removed</p>
Power Switch	<p>Slide switch on circuit card (SW1). This switch disconnects power to the main circuit cards and LCD display.</p> <p>NOTICE: A switch or circuit breaker must be provided in the installation, which can remove power from the Q-Controller in case of emergency or any other related requirement.</p> <p>Since the Q-Controller enclosure can be locked to prevent unwanted tampering, the internal power switch is not</p>

	<p>guaranteed to be accessible.</p> <p>Feeding the Q-Controller power from a rack main switch or from a switch in a distribution box is adequate.</p>
Enclosure	<p>UL 508 Type 1, 2, 3, 4, 4X, 12 and 13 CSA Type 1, 2, 3, 4, 4X, 12 and 13 NEMA Type 1, 2, 3, 4, 4X, 12 and 13 IEC 60529, IP66 Flammability V-O per UL 94 UV rating (f1) per UL746C</p>
Environmental conditions	<p>Location: Indoor use only Altitude: Up to 2 000 m Temperature: 0 °C to 49 °C Relative Humidity: 85±5 % RH for temperatures up to 30 °C decreasing linearly to 50 % at 40 °C. Pollution Degree: 3, in accordance with IEC 664. Installation Categories (Overvoltage Categories) II</p>
Display & Keypad	<p>7 inch LCD touchscreen display delivers 800 x 480 resolution and offers a capacitive multi-touch TN panel for easily navigate screen</p>
Panel Indicators	<p>15 Status LEDs Power Status USB TX/RX status 4 RS-485 port TX/RX Status for Sensor Network 1 RS-485 port TX/RX Status for Modbus 1 RS-485 port TX/RX Status for BACnet Module BAC-Box</p>
On-Board Relays	<p>4 pluggable Relays SPDT, Dry contacts Resistive load: 10A at 250VAC 10A at 30VDC Inductive load: 7.5A at 250VAC 5A at 30VDC</p>
On-Board Switch Inputs:	<p>4 channel switch inputs The switch can be Q-Switch or any ON-OFF switch</p>

On-Board Buzzer	Used for internal warning and alarm, 3700 Hz Continuous It's not used for Alarm-Sounding Appliance. For external Alarm-Sounding Appliance, they can be connected to the below Horn/Strobe terminal blocks, the Alarm-Sounding Appliance sound-pressure level should be at least 85dB at 10 feet according standard UL2017 Audibility Test
Horn & Strobe	Two relay dry contact are for Horn and Strobe Dedicated 24VDC terminals are supplied for connection to standard strobe and horn set. Maximum of 750mA on the 24VDC power supply
Remote Devices	4x RS-485 Ports with ACI Controller Protocol - Available ACI digital transmitters, such as Q5C - Available I/O box: AI-Box, AO-Box, BI-Box, BO-Box
Modbus Slave Port	RS-485 port Responds as a Modbus Slave using RTU protocol. Q-Controller supplies read status information only
BACnet Port	RS-485 port Connect to ACI BACnet/IP module BAC-Box
Certification	UL2017 Standard for Safety General-Purpose Signaling Device and Systems Project#: G103011776 for Canada, G103014445 for US, for details, contact ACI. Tested with ACI gas transmitter Q5C and IO-Box ACI Q5C is certified with UL2075 Standard for Safety

4 Q-Controller Installation

4.1 Type and Location

The Q-Controller is designed and certified for installation in a fixed location. The location should be indoors and dry. Please observe the temperature and humidity specifications above for ambient conditions. Observe the possibility of leaks or possible water damage from cleaning done in the area.

4.2 Method

Four mounting screw locations are provided on the base of the enclosure. The unit should be mounted to a wall or other fixture that remains in a fixed location.

4.3 Positioning

The mounting height and location should provide easy access to the wiring terminals and front-panel. Backlighting is provided for the display in case of low lighting conditions.

4.4 Cabling

Approved cable conduit and conduit connectors should be used to ensure a safe and reliable installation. Check the local wiring code for more information. Make sure all conduit connectors are screwed in tight and that they are not coming in contact with any bare conductor.

Strain relief should be installed to the enclosure to prevent any mechanical stress from being transmitted to terminals and internal connections.

We recommend using BELDEN 9841 for communications. This wire has 120 ohm input impedance, which will eliminate RS-485 communication problems.

ACI warrantees and support only covers installation with proper cable. If in doubt please contact ACI support personnel.

4.5 Connectors

The terminal block TB1 to TB20 accept 12 AWG to 24 AWG wire, Use 16 AWG or 18 AWG wire for Power Supply in long wiring runs, which can be up to 1km (1,000 meters) long.

Make sure to observe wiring to the correct terminal blocks. Removable terminal blocks are provided. Make sure there is no confusion about which terminal block to wire to.

Note: Incorrect wiring to any of the terminals of the Q-Controller could cause permanent damage to the unit, which is not covered by the warranty. Incorrect wiring could also cause

fire, electric shock, or bodily injury. Please observe the polarity on all connections.

Warning: Disconnect the mains supply and switch off the Q-Controller when changing any of the wiring to the unit. Be especially cautious when wiring high voltage to the relays. Do not touch sensitive components on the circuit card to prevent static discharge damage to the unit.

4.6 Mount Installation

It is recommended that controllers be installed 5 feet (1.5 m) above the floor, at approximate eye level. Securely mount the Q-Controller using the appropriate screws.

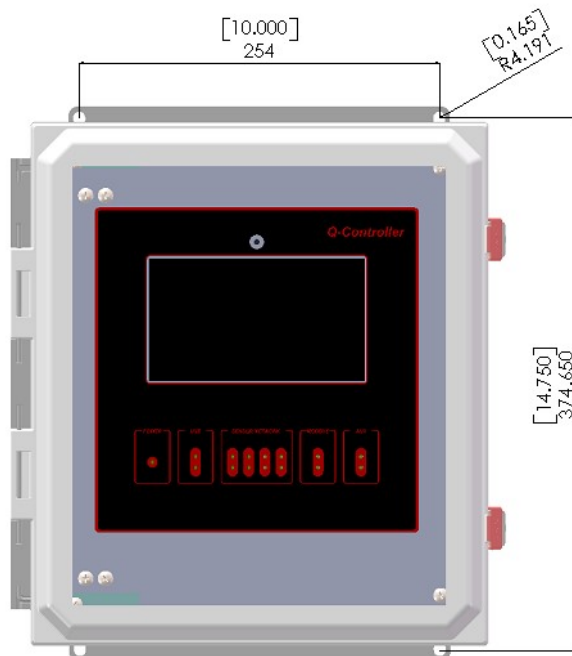

The enclosure is a NEMA 4X rated enclosure and can be wall mounted with 4 screws. To maintain the NEMA rating, it is important that the conduit opening is sealed upon installation.

4.7 Power Requirements

The Q-Controller power supply voltage requirements are nominally 24VAC or 24VDC

NOTE: Input Power is half-wave rectifier circuit, it can be either non-grounded or grounded. You will damage devices if you mix half wave and full wave rectifiers on the same AC source. Use extreme caution when sharing a common AC source. Sharing a common DC source is less problematic.

General Guideline:

- Q-Controller uses half-wave rectifier only
- Q5 TB5 is half-wave rectifier
- Q8 TB6 is half-wave rectifier
- All I/O boxes are half-wave rectifier
- It is okay to connect multiple devices to the same AC transformer and share signal commons if
 - Every device uses a half-wave rectifier
 - And the same AC lead on every device is used for common
- If the power supply is 24VAC, no matter it is GROUNDED (one side of AC is connected to ground), or FLOATING (neither side of AC is connected to ground), the polarization is important, make sure the Neutral or the same AC lead is connected to the GND of TB10. Make sure the same AC lead is connected to ground in all devices that share the AC source. Treat AC like DC for purposes of watching polarity in this case.
 - For Q5, the TB5 of Q5 can only be connected to the same AC source
 - For Q8, the TB6 of Q8 can only be connected to the same AC source
 - For I/O boxes, they can be directly connected to the same AC source
 - For other devices, only the device with half-wave rectifier can be connected to the same AC source. If it doesn't have, or any doubt exists, provide a dedicated isolated transformer to the device
- If the power supply is 24VDC, all the devices can be powered by the same DC source.
- Whenever you have different devices from different manufacturers, be careful to separate those devices that utilize a Full-wave rectifier from those using a Half-wave rectifier. When any doubt exists, provide a separate transformer. The small expense of an additional transformer or two will more than make up for all of the time and money spent on troubleshooting
- Please refer to Q-Controller Installation Drawing for power & RS-485 Connection
- It is necessary to bear in mind the actual installation when sizing the transformer. The installation requirements can run theoretically from only 15 VA to over 200 VA. These systems ranging from a single controller, a few electrochemical sensors to a full 128 Combustible sensors with several remote relay modules.
- It is always best to allow some safety margin in designing power supplies, and 25% to 50% allowance for startup surges and future requirements is recommended.

ACI supplies one standard transformer

M-Transformer 120 to 24 VAC 200 VA

4.8 RS-485 Installation

The RS-485 (EIA-485) standard specifies the electrical characteristics for a digital communication link allowing communication between multiple devices on a single link. The RS-485 uses two wires, A+ and B-, and works on the voltage difference between them. If the voltage difference is positive, then that is a “1” if negative then that is a “0”.

Connections: Wire terminals A+ to A+ to A+ etc., and B- to B- to B- etc.

End-Of-Line Termination Resistance: The terminator on each end of the RS485 loop is designed to match the electrical impedance characteristic of the twisted pair loop, and will prevent signal echoes from corrupting the data on the line. The terminator should be enabled on BOTH ends of the RS485 loop. Short and medium length modbus/485 loops can operate without the terminating resistor. Longer runs may require the terminating resistors. But adding terminator dramatically increases power consumption. All ACI equipment supplies the end-of-line resistor on the circuit card. It is enabled or disabled with a shunt jumper. (See relevant Installation Drawings for information).

Q-Controller supplies this resistor on the main board, and it is chosen using a jumper at J2, J5, J7, J8 and J9.

 **JX 1-2: Terminator Disabled /OFF (Default)**

 **JX 2-3: Terminator Enabled /ON**

Factory default setting is disabled terminator.

Distances: The RS-485 standard allows up to 1300 meters (4000 feet) of line length. It is best to avoid lines of this length if at all possible.

Stubs: Short lengths of cable from the main cable over to a device are called Stubs. When the Baud rate (communication bit rate) is low – e.g. 2400 baud, then it is often possible to use short lengths of a few inches without seriously impairing the signal integrity, especially when overall distances are relatively short; however, this is taking a chance on garbling your signals and is not recommended.

Cable Shields: Cable shields are aluminum and so only ‘proof’ against electrical fields, not against magnetic fields. The twist in the pair is to reduce the effects of magnetic fields. Take care not to run cable close to magnetic sources. Iron conduit is a good shield for both electrical and magnetic fields.

Shield Grounding: There are certain things to keep in mind for the shield.

- The shield must be grounded otherwise it can make the situation worse.
- Ground the shield at only one end to prevent ground loops.

- If you cut the cable then either ground each section of the shield at that point or connect the shields together to ground back at an origin point.

Devices and Ports: The RS-485 standard allows up to 32 devices on each communication line. The Q-Controller supports up to 256 ACI devices on each RS-485 port. The Q-Controller does not need to be at the end of the line. The Q-Controller has four RS-485 ports for remote devices (digital sensors and I/O modules). The ports are logically parallel so that it does not matter which port a sensor is connected to. This allows flexibility of wiring to suit wiring for zones, and reduction of length of lines. Minimizing the installation total wiring distances increases the reliability of the system.

RS-485 Driver Replacement: RS-485 lines in heavy industrial environments are sometimes subjected to magnetic disturbances causing sufficient inducted power surges to damage the driver integrated circuit (IC). This IC U6, U7, U10, U11, U13 and U16 have sockets on the circuit card for ease of replacement in the field.

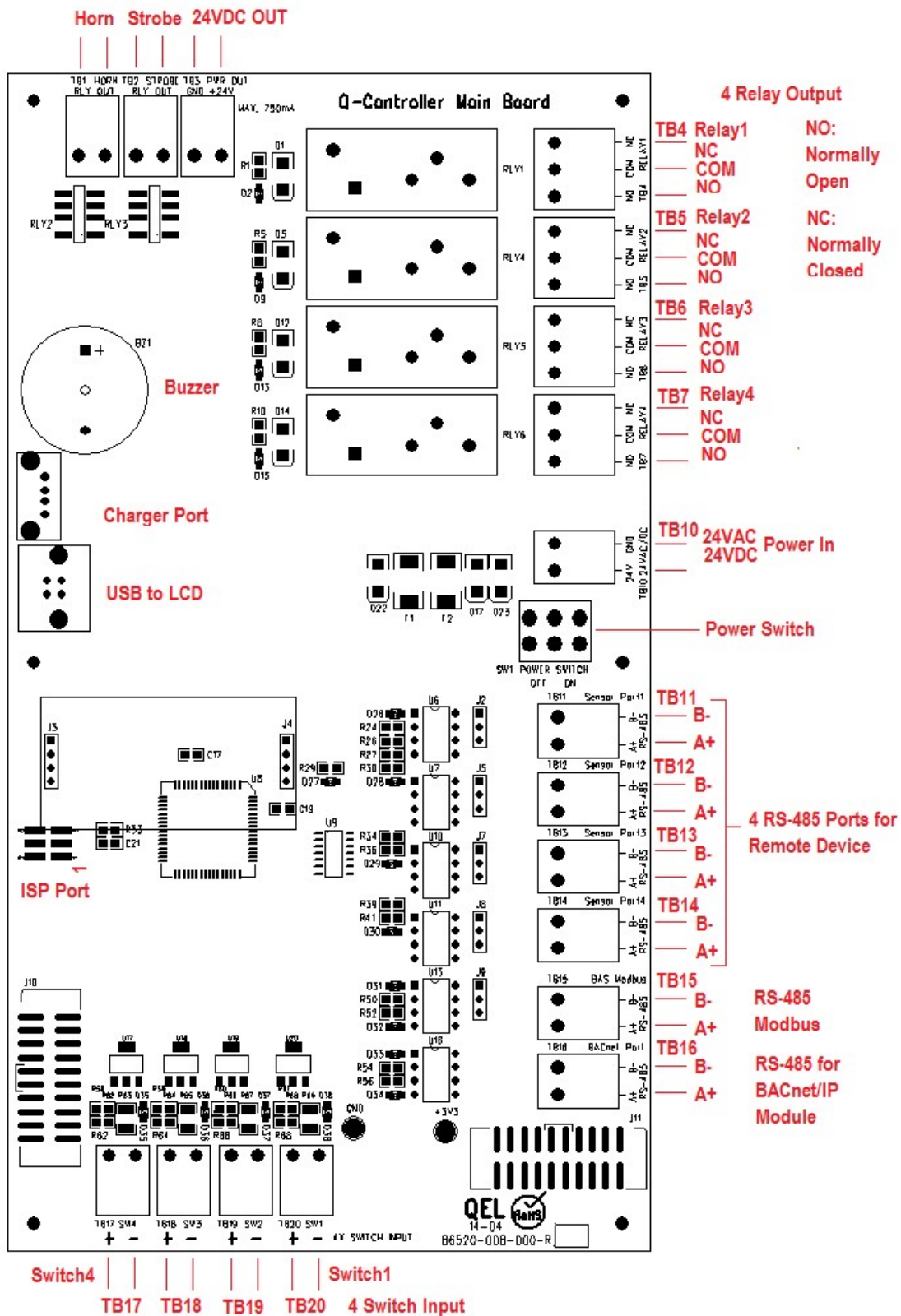

5 Q-Controller Functions

5.1 Initial Startup

Make sure that all wiring has been completed according to specifications in the wiring details before powering up the unit. When all is secure, switch the Power Switch to ON position to power-up the unit. It should only take a few seconds until the unit is fully operative. After it fully powers up, it will automatically enter into Monitoring Mode. As there is no device enabled as the factory defaults, so the LCD display will look like below.

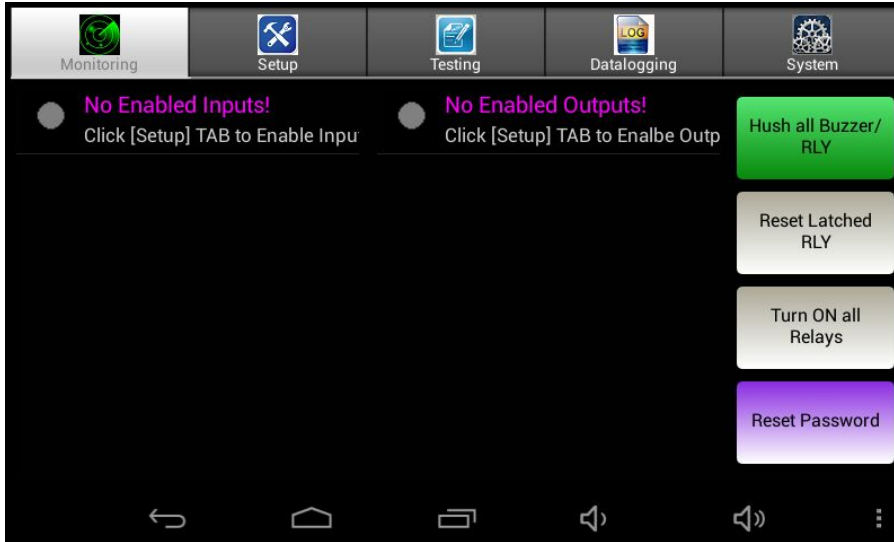

If the tablet is not powered up automatically, it may have run out of battery. Press the power button on the tablet to manually turn on the tablet.

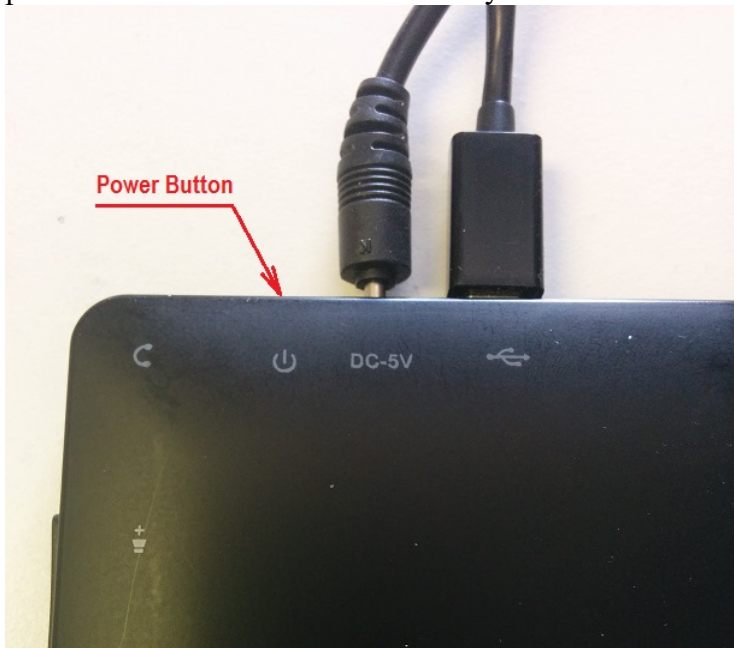

If the Q-Controller Monitoring program does not run automatically, click the icon of the Q-Controller QC-MMI to run Q-Controller Monitoring program

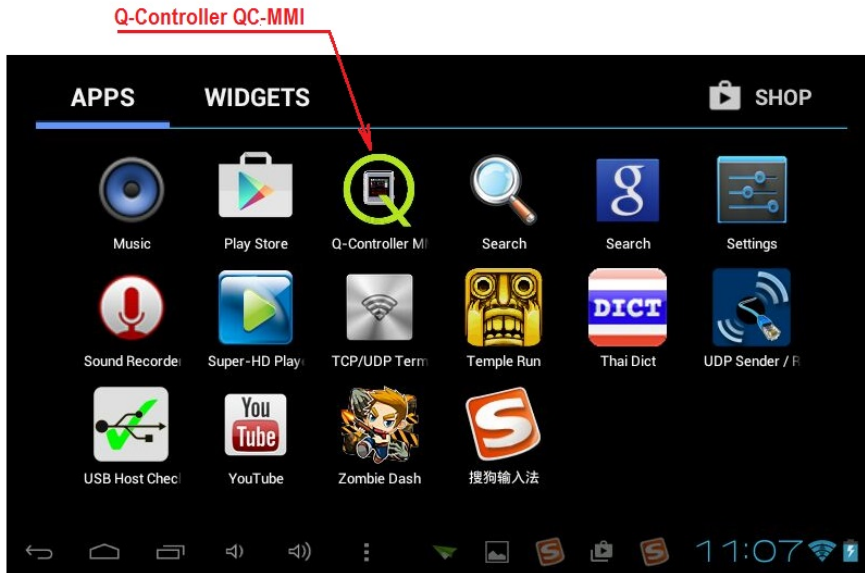

5.2 System Settings

5.2.1 System Options...

Before setup and define how sensors and relays function together, the Q-Controller needs to know how many remote devices are connected to it. Click [System] tab to config the Q-Controller. It's password protected. **Default password is 4321.**

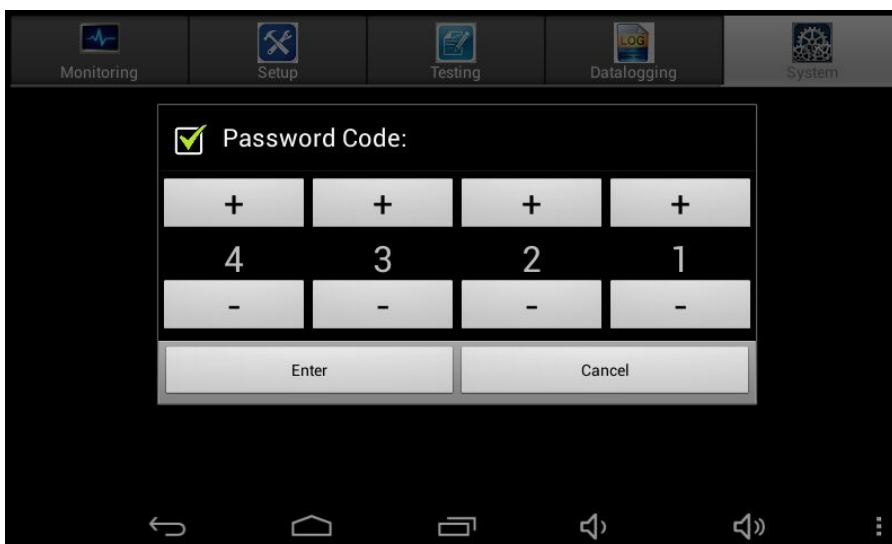

Once the password is accepted, it will enter into System Menu.

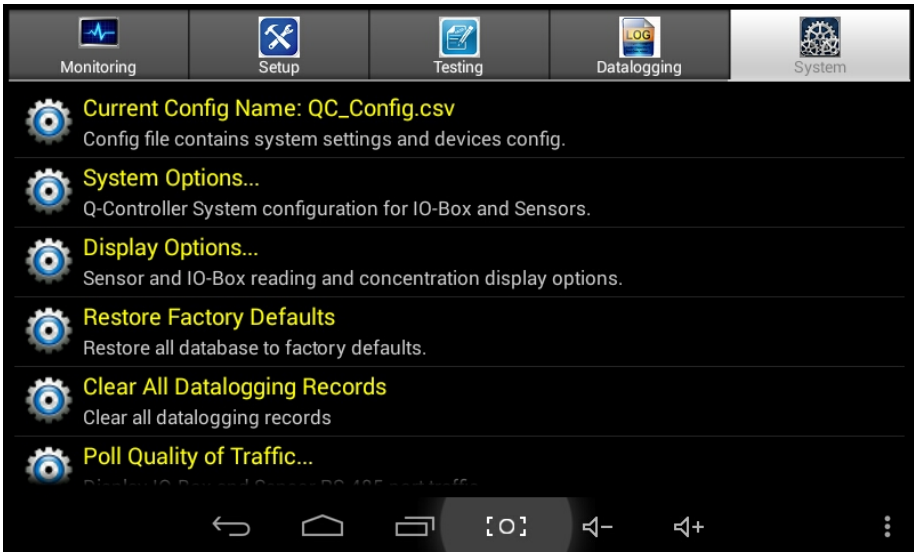

. Click [System Options] to configure the Q-Controller



Setting	Description
IO-Box Icons:	To input the amount number of the connected devices
Change Password:	Change Password allows any combination of up to four digits. Default is 4321. Warning: Be sure that you record the new password in a safe and secure location!

Monitoring Mode:	Set the Q-Controller to read all connected inputs and control outputs in real time
Simulation Mode:	Simulation is to assist in testing the installation before commissioning. When the simulation mode is selected, the Q-Controller will stop polling remote input devices, you can manually input simulation gas value or switch input status in tab [Monitoring] screen. The Q-Controller will display the simulating value and use it to calculate the statuses of relays and buzzer, as well as 4-20mA analog output. This feature is able to evaluate the user settings and testing the installation (e.g.: the travel of the valve, fan speed, relay set points, etc. can be verified.)
Calibration Mode:	This function is for calibration, system testing etc. When the calibration mode is selected, the relay, buzzer and analog output, etc., statuses will freeze in whatever state they are already in.

. Click Q-Controller icon to configure the Q-Controller communication settings

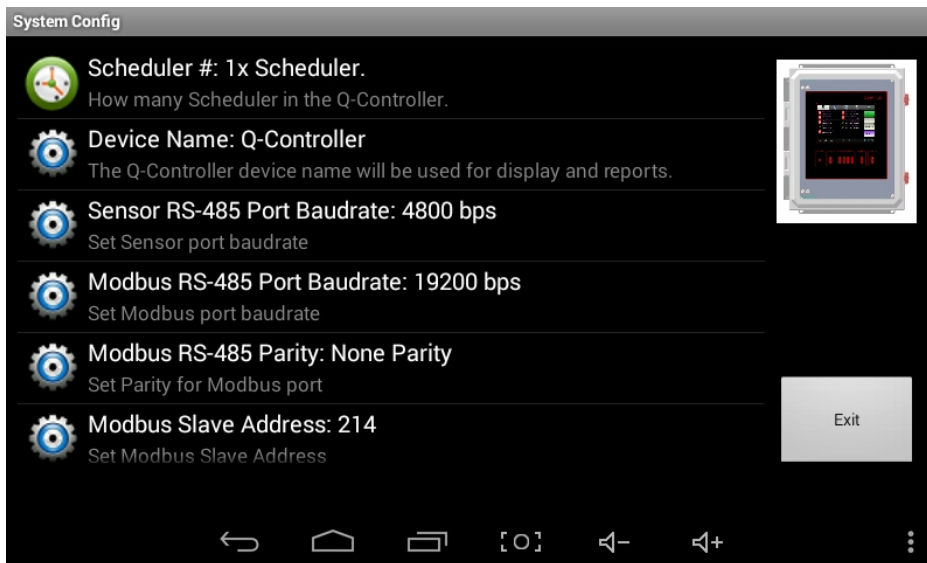

Scheduler #	How many Schedulers in the Q-Controller System
Device Name:	The name will be used to display for this Q-Controller. It's also used to be model name in Device Object in BACnet /IP protocol

Sensor RS-485 Port Baudrate:	Baud Rate for the 4x RS-485 Port at TB11 to TB14 remote device network OptoMux protocol, default 4800bps
Modbus RS-485 Port Baudrate:	Baud Rate for RS-485 Port for Modbus protocol, the Q-Controller responds as a Modbus slave using RTU protocol. Default is 19200 bps.
Modbus RS-485 Parity:	The parity bit can be set to “EVEN”, “ODD” and “No Parity”. Default is “No Parity”.
Modbus Slave Address:	The assigned address is the Q-Controller as a slave device in Modbus protocol. Range 1 to 247. Default is 214.
Hush Period Timer:	When a hush button or hush style switch is pressed to silence Buzzer/Horn and buzzer style relays, the timer is active at the same time. When the timer is timeout, the hush button will be expired and will not silence the buzzer/horn and relays any more. If the alarm is still present, the buzzer/horn and relays will be actuated again. Expired switch needs to manually reset (push again) in order to function again. Default is 5 minutes
Reset Relay Period Timer:	When a reset style switch is pressed to manually reset its assigned relays, the relays will be overridden to reset, the timer is active at the same time. When the timer is timeout, the switch input will be expired and the relays will not be overridden any more. If the alarm is still present, the relays will actuate again. Expired switch input needs to manually reset in order to function again. Default is 5 minutes
Exit:	Save settings and Return to previous menu

5.2.2 Display Options...

. Click [Display Options] to configure the Q-Controller display

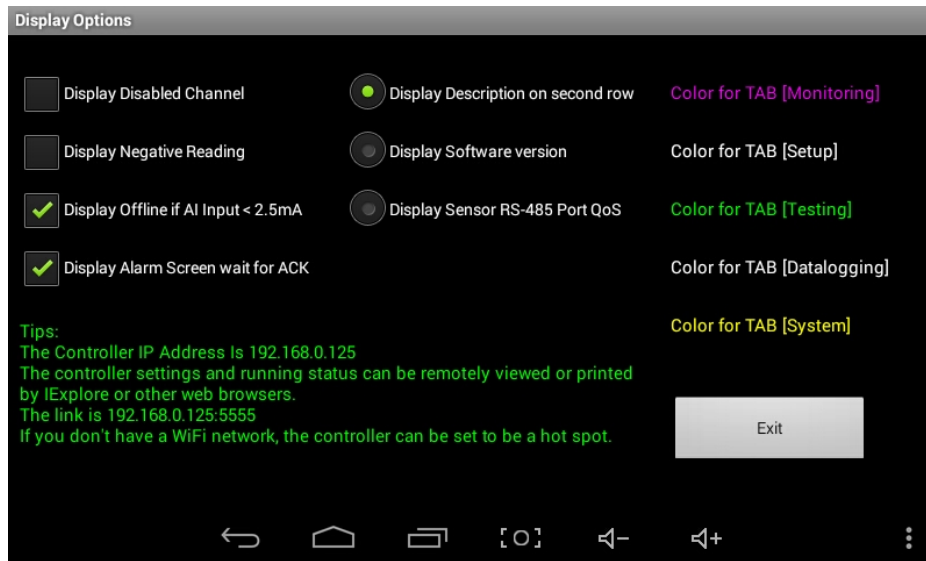

Setting	Description
Display Disabled Channel:	When a remote module is connected and you may disable any unused channels. If it's "Checked", the disabled channel will be displayed in tab [Monitoring]. If it's "Unchecked", the disabled channel will not appear in tab [Monitoring] screen.
Display Negative Reading:	It only works on the digital sensors and Analog Inputs value. If it's "Unchecked", all negative readings will be displayed as "0"
Display OFFLINE if AI Input < 2.5mA:	The feature only works on the Analog Inputs value. If it's "Checked", the AI channel will report "CH OFFLINE" when the input signal is less than 2.5mA. If it's "Unchecked", the reading will be zero or negative reading if "Display Negative Reading" is "Checked".
Display Alarm Screen and Wait for ACK:	When any alarm or output status changed, a red color flash screen will be displayed if it's "Checked", it can only be cancelled by clicking the right button [Acknowledge] to acknowledge the alarms. If it's "Unchecked", no flash screen is popped up.

Setting	Description
<ul style="list-style-type: none"> Display Description on second row: 	There are three options for the second row display in the tab [Monitoring], in normal monitoring mode, the description is displayed.
<ul style="list-style-type: none"> Display Software version: 	If you want to check what software version in the remote devices, you can choose “Display Software version”. This setting will be reset after the APP is restarted.
<ul style="list-style-type: none"> Display Sensor RS-485 port QoS: 	If you want to display the Quality of Traffic or Network Service in the remote devices, you can choose “Display Sensor RS-485 port QoS”. This setting will be reset after the APP is restarted. The QoS reading of each remote device can only be read out from performing the function of “Poll Quality of Traffic...”

Setting	Description
Change TAB TextColor:	You can customize the text color in tab [Monitoring], [Setup], [Testing], [Datalogging] and [System]

5.2.3 Other System Settings

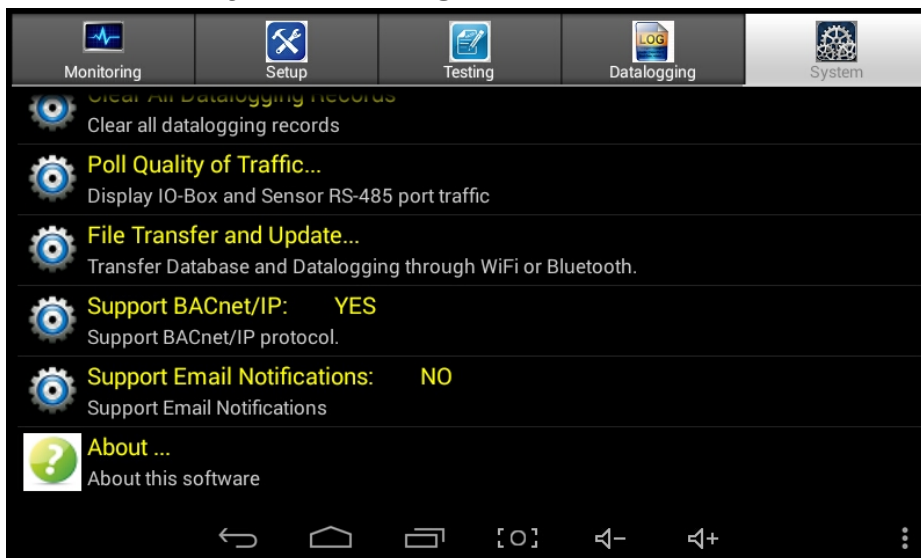

Setting	Description
Restore Factory Defaults:	To load factory defaults to system settings, to restore the unit to correct operation.
Clear all datalogging Records:	Delete datalogging records and event logging records
Poll Quality of Traffic...	Q-Controller reads the QoS data out of each remote device. The QoS data contains the amount of polling command sent from Q-Controller and the amount of the reply data sent out of the remote device. It reflects the command pass rate.

File Transfer and Update... It will pop up a screen to show the Q-Controller’s IP address in a wireless network through Wi-Fi, so you can run Android app QC-Mate in your Android devices, such as cellphone or tablet to remote connect to the Q-Controller through Wi-Fi or internet.

The datalogging database and event database can only be downloaded to your Android devices.

The system configures file can be downloaded and uploaded between your Android devices and Q-Controller. It’s saved to the root directory of the device; you have to open the file manually to have the file as current setting file.

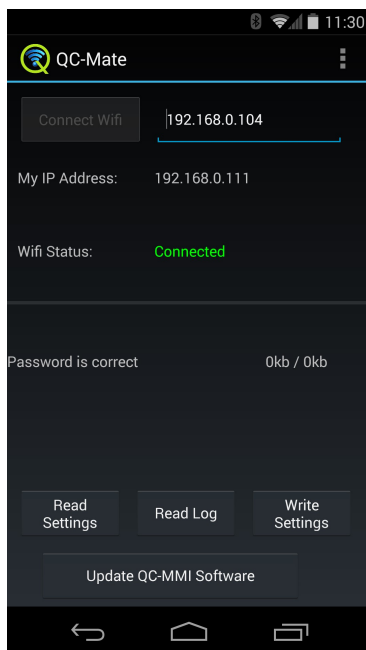

You can download the software QC-Mate from “Google Play Store” to your

Android device. iPad is not supported.

QC-Mate App Link:

https://play.google.com/store/apps/details?id=com.ACIsafety.QC_mate&hl=en

Q-Controller Wi-Fi is able to connect to a network or internet via a wireless Access Point (AP) or Hotspot. Consult your network administration on internet access.

Q-Controller can be set to be a hotspot too. It's default IP address is 192.168.43.1

Support BACnet/IP:: Setup ACI BACnet/IP module "BAC-Box", with the module, the Q-Controller is able to connect to a BACnet network via TCP/IP networks.

BAC-Box supports DHCP and static IP both IP address assignments. Each device must have a unique IP address on a network. Your system administrator generally provides the IP address and corresponding subnet mask and gateway if static IP address is selected.

Support Email Notifications: Q-Controller can send an email to multiple recipients when any alarm is detected. It is also able to send a daily datalogging file to multiple recipients or just the current configuration file and datalogging file to multiple recipients.

Email setup requires SMTP Server and sent from email address and password. Gmail is preferred and tested.

About ... About Q-Controller QC-MMI software version

5.3 Setup Devices

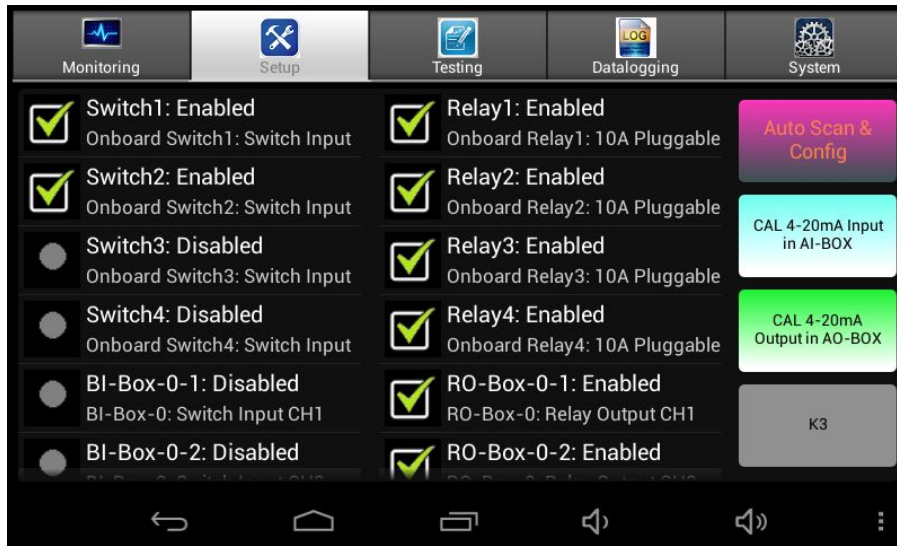

5.3.1 Name Devices and Addressing

The term “sensor” used throughout means a digitally communicating sensor/transmitter unless otherwise stated. It can be any ACI digital sensor, such as Q5, Q8, M5, M17, QIRF, QTS-8000 etc.

The Q-Controller supports up to 128x remote digital sensors, 16x AI-Box, 16x AO-Box, 31x BI-Box and 31x BO-Box.

In order to communicate with Q-Controller through the 4x RS-485 Sensor ports, each device must have a unique address in its device group.

- For digital sensors, the acceptable addresses are 0 ... 127
- For AI-Box, the acceptable addresses are 0 ... 15
- For AO-Box, the acceptable addresses are 0 ... 15
- For BI-Box, the acceptable addresses are 0 ... 30
- For BO-Box, the acceptable addresses are 0 ... 30

Sensor is named from Sensor 0 to Sensor 127.

AI-Box is named from AI-Box-0 to AI-Box-15.

AO-Box is named from AO-Box-0 to AO-Box-15.

BI-Box is named from BI-Box-0 to BI-Box-30.

BO-Box is named from RO-Box-0 to RO-Box-30.

Channel Number:

The last digit in the BI-Box-0-2 is the channel number, so “BI-Box-0-2: Disabled” in the screen means the second channel in the address 0 of BI-Box is disabled.

5.3.2 Auto Scan & Config

Click the button [Auto Scan & Config] on the right corner of the screen, the Q-Controller will automatically scan all online devices and generate a config file for all devices setup. It will replace the existed config file in the Q-Controller, and not all information can be generated, so we strongly recommend setting up each device individually and manually.

5.3.3 Cal 4-20mA Input for AI-Box

This feature is only for factory calibration.

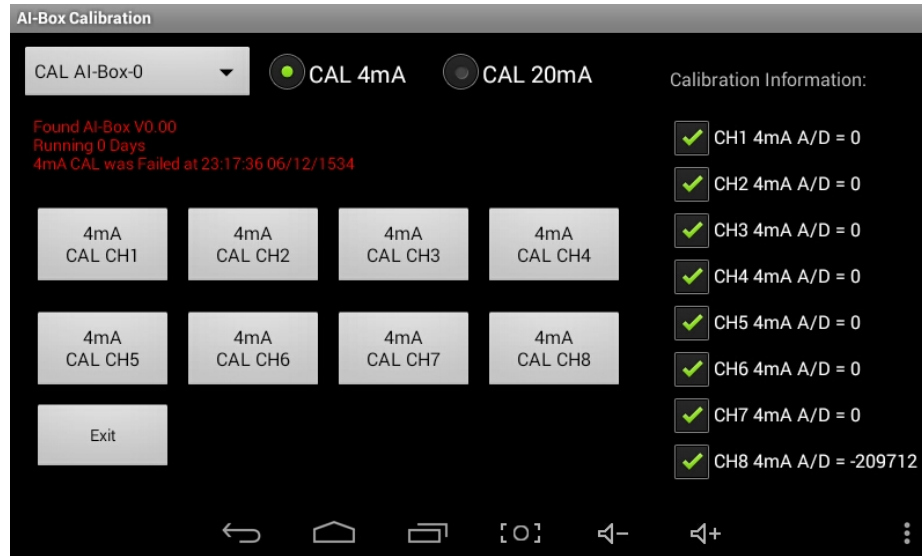

Settings	Description
Drop list “CAL AI-Box-0”	The Address of the being calibrated AI-Box. It supports AI-Box-0 to AI-Box-15. Each AI-Box can be calibrated individually on the bus.
CAL 4mA	Each channel of the AI-Box can be calibrated individually. Apply 4mA signal to Channel 1 to Channel 8 of the AI-Box, then click the each channel button [4mA CAL CHx] to calibrate the 4mA signal, the AI-Box will sample the value and store it to the AI-Box EEPROM. The value will be displayed on the right side of “CHx 4mA A/D = XXXX”
CAL 20mA	Apply 20mA signal to Channel 1 to Channel 8 of the AI-Box, then click the each channel button [20mA CAL CHx] to calibrate the 20mA signal, the AI-Box will sample the value and store it to the AI-Box EEPROM. The value will be displayed on the right side of “CHx 20mA A/D = XXXX”

Warning: This procedure is part of factory setup. In most circumstances it will not be necessary to perform this procedure in the field. These functions require the use of precision reference instrumentation.

5.3.4 Cal 4-20mA Output for AO-Box

This feature is only for factory calibration.

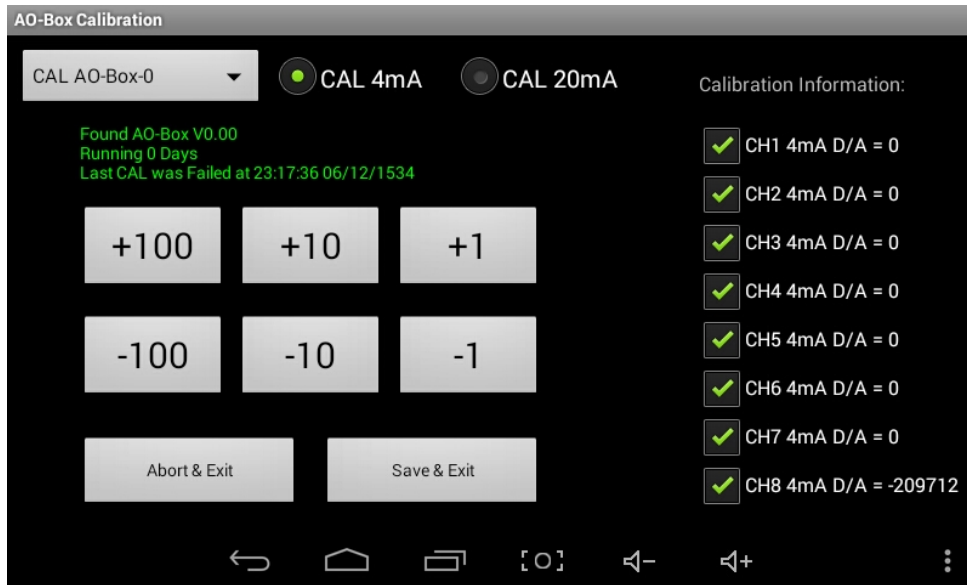

Switch	Description
Drop list “CAL AO-Box-0”	The Address of the being calibrated AO-Box. It supports AO-Box-0 to AO-Box-15. Each AO-Box can be calibrated individually on the bus.
CAL 4mA	Connect a current meter to the being calibrated channel. Click the six buttons [+100] to [-1] to adjust the D/A output on the channel so that the channel output is measured at 4.00mA. The D/A value will be displayed on the right side of “CHx 4mA D/A = XXXX” Calibrate all 8 channels individually
CAL 20mA	Connect a current meter to the being calibrated channel. Click the six buttons [+100] to [-1] to adjust the D/A output on the channel so that the channel output is measured at 20.00mA. The D/A value will be displayed on the right side of “CHx 20mA D/A = XXXX” Calibrate all 8 channels individually

Save & Exit	Click the button to save the calibrated values for 4mA and 20mA signal to the AO-Box EEPROM and return to previous menu
Abort & Exit	Click the button to return to previous menu without saving any information, but AO-Box still has nothing to change

Warning: This procedure is part of factory setup. In most circumstances it will not be necessary to perform this procedure in the field. These functions require the use of precision reference instrumentation.

5.3.5 Switch Input Setup

Click any switch or BI-Box on the screen will enter switch configuration screen.

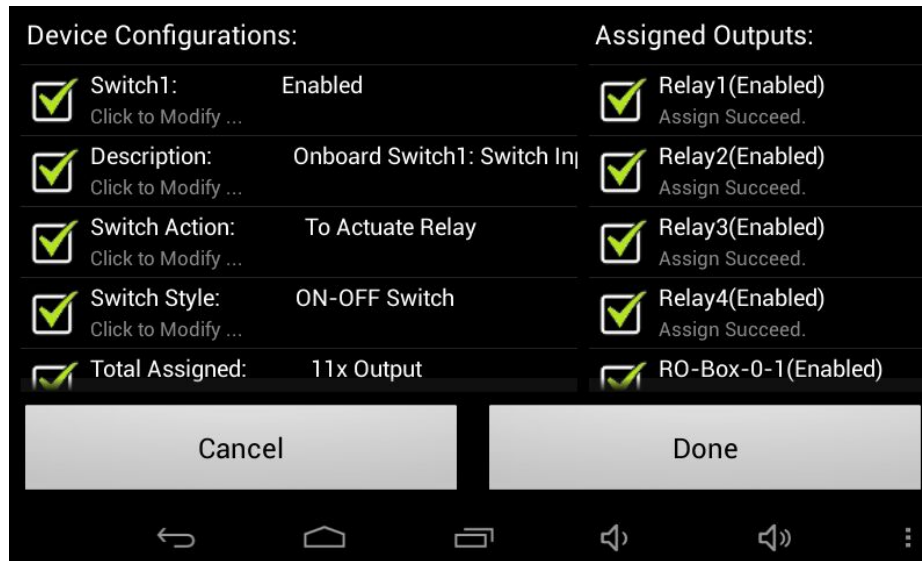

Switch	Description
Enable/Disable	Q-Controller only monitors and controls enabled devices. Q-Controller will ignore the device if the device is disabled.
Description	Each device or channel description can be modified to describe exactly what it can do or to be easy identified.
Switch Style	Q-Controller only supports ON-OFF Switch
Assigned Output	Define which outputs the switch will trigger to when the switch is ON. How to actuate the outputs will depend on the Switch Action.
Total Assigned	Summary for assigned output

Each switch can be defined to one of the four actions to work with the assigned outputs.

Switch Action	Description
To Reset Relay:	When the switch is ON, the assigned output (Relays and Buzzers) will be overridden to RESET (OFF State) for the time of Reset Relay Period Timer. The switch can be used to reset alarmed relay or buzzer.
To Actuate Relay:	When the switch is ON, the assigned output (Relays and Buzzers) will be overridden to ON state. The switch can be used to manually actuate assigned relay or buzzer.
To Hush Buzzer and Relay:	When the switch is ON, the assigned output (Relays and Buzzers) will be hushed for the time of Hush Period Timer.
To Reset Latched Relay:	When the switch is ON, all latched relays will be reset. The switch needs to press again to switch OFF manually when it's shown "Expired".

NOTE: As the switch is ON-OFF style switch, it may show "Expired" in Monitoring mode when the switch has lost its function due to the switch timeout or the function has been performed at the same time the switch is still ON. At this situation, the switch needs to press again to switch OFF manually.

Click button [Done] will save the configuration to Q-Controller and exit to previous screen. Click button [Cancel] will exit to previous screen without saving.

5.3.6 Sensor Setup

Click any sensor list item will enter sensor configuration screen.

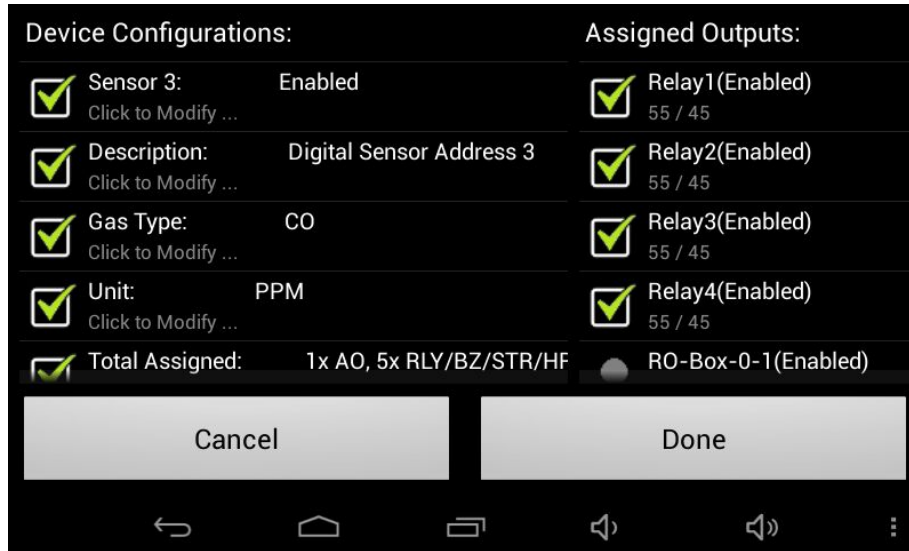

Sensor	Description
Enable/Disable	Q-Controller only monitor and control enabled devices
Description	Description for this sensor
Gas Type	The gas type of the sensor
Unit	The Unit of measurement of the sensor
Assigned Output	Define which outputs the sensor will assign to. If the output is working on Voting Mode, the ON Concentration and OFF Concentration will be asked. See NOTE below. If the output is working on Averaging Mode, the sensor's concentration will be counted with other assigned sensors to calculate the averaging concentration

NOTE:

If On Concentration is great than or equal to Off Concentration:

On Concentration: For each sensor or analog input assigned, set the concentration at or above which the sensor or AI will be in Alarm Status and will be counted into Voting Number.

Off Concentration: For each sensor or analog input assigned, set the concentration at or below which the sensor or AI will return to Normal Status.

If On Concentration is less than Off Concentration:

On Concentration: For each sensor or analog input assigned, set the concentration below which the sensor or AI will return to Normal Status.

Off Concentration: For each sensor or analog input assigned, set the concentration above which the sensor or AI will be in Alarm Status and will be counted into Voting Number.

5.3.7 AI (Analog Input) Setup

Click any AI-Box list item will enter AI configuration screen.

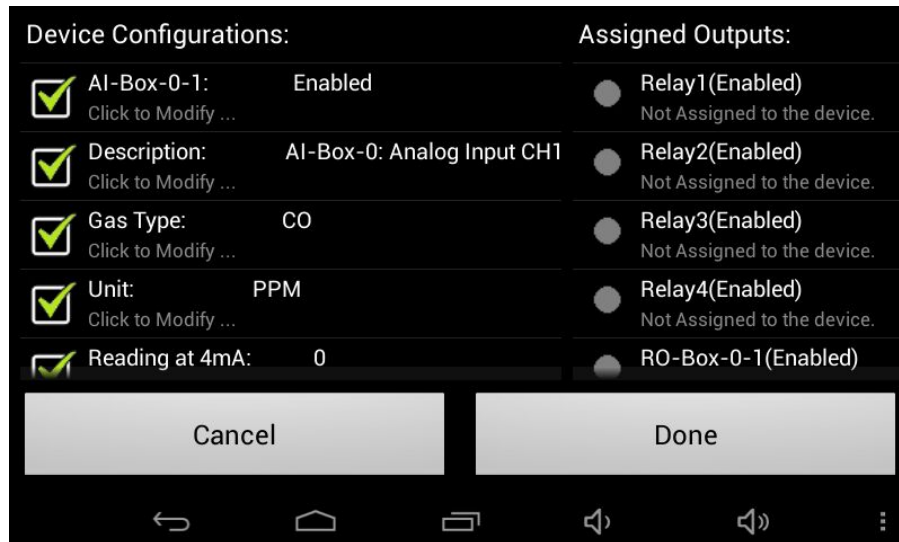

AI-BOX	Description
Enable/Disable	Q-Controller only monitor and control enabled devices
Description	Description for this AI channel
Gas Type	The gas type of the AI channel
Unit	The Unit of measurement of the AI channel
Reading at 4mA	Measure Range: Assign the two readings at 4.0 milliamps and 20.0 milliamps input signal. You may even assign a gas concentration to 4 mA, which is higher than the concentration assigned to 20 milliamps. The Q-Controller will draw a straight line between.
Reading at 20mA	See above
Assigned Output	Define which outputs the channel will assign to. If the output is working on Voting Mode, the ON Concentration and OFF Concentration will be asked.

5.3.8 Scheduler Setup

Q-Controller supports up to 8 schedulers on-board. Scheduler is used as a periodic schedule of events that may repeat within a range of dates/time.

Click any scheduler list item will enter scheduler configuration screen.

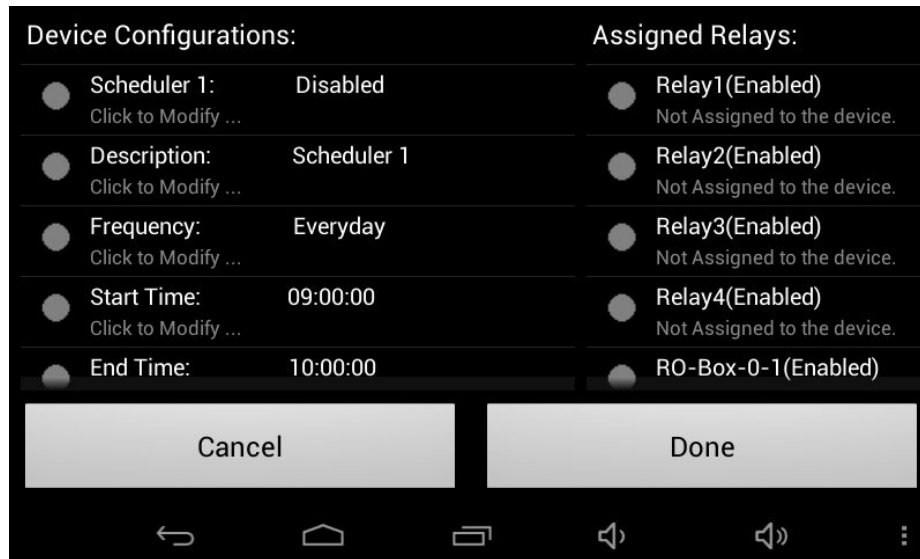

Sensor	Description
Enable/Disable	Q-Controller only monitor and control enabled devices
Description	Description for this scheduler
Frequency	<ul style="list-style-type: none"> • Only Once: The scheduler only works once • Every Weekday: The scheduler works on weekday • Every Weekend: The scheduler works on weekend • Every day: The scheduler works everyday
Start Time	The assigned outputs will be actuated from the time
End Time	The assigned outputs will be reset from the time
Assigned Output	Define which outputs the scheduler will trigger and actuate to.

5.3.9 Relay Setup

Click any relay or RO-Box list item will enter relay configuration screen.

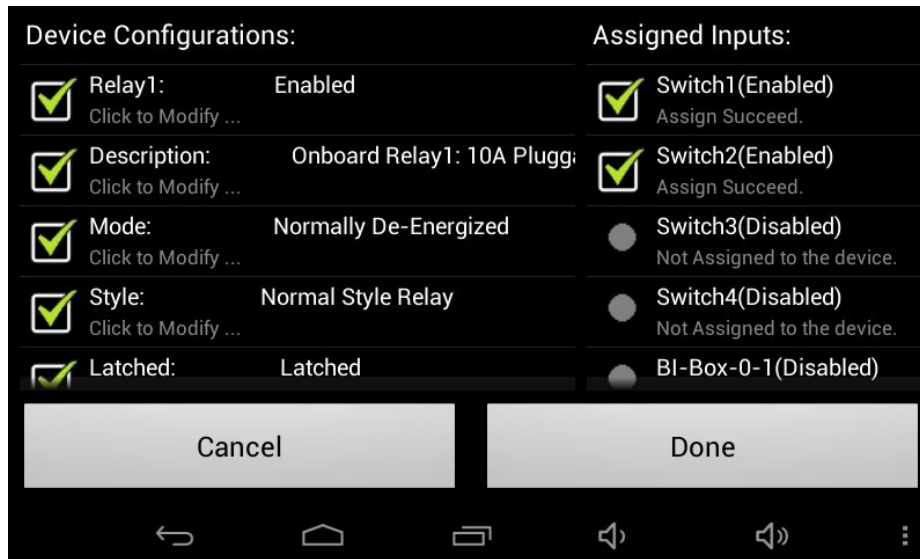

Relay	Description
Enable/Disable	Q-Controller only monitor and control enabled devices
Description	Description for this relay
Mode	Each relay may be individually set to be <ul style="list-style-type: none"> • Normally De-Energized • Normally Energized
Style	<ul style="list-style-type: none"> • Normal Style Relay • Buzzer Style Relay <p>The Buzzer Style Relay can be reset by HUSH button or Switch Input with Hush Action</p>
Latched	<ul style="list-style-type: none"> • Latched • Non-Latched <p>The Latched Relay will be latched in actuate status until acknowledged by the button [Reset Latched RLY] on the Monitoring Screen or Switch Input with Reset Latched Relay Action</p>

Mode	<ul style="list-style-type: none"> • Voting Mode If the Relay is set to Voting Mode, The voting number will be asked • Averaging Mode If the relay is set to Averaging Mode, the Average ON and Average OFF will be asked
Voting Number	<p>Only work in Voting Mode</p> <p>For a given list of sensors and AI assigned to a relay actuation list, this number indicates the minimum number of sensors which must pass or equal their alarm “On Concentration” before the relay will actuate</p> <p>For “On Concentration” and “Off Concentration”, see NOTE in Sensor Setup</p>
Average ON	<p>Only works in Averaging Mode</p> <p><i>If Average On is great than or equal to Average Off:</i></p> <p>Average On: The gas concentration at or above which the average of all the sensors assigned to this relay will cause the relay to actuate.</p> <p>Average Off: The gas concentration at or below which the average of all the sensors assigned to this relay will cause the relay to de-actuate.</p> <p><i>If Average On is less than Average Off:</i></p> <p>Average On: The gas concentration at or below which the average of all the sensors assigned to this relay will cause the relay to actuate.</p> <p>Average Off: The gas concentration at or above which the average of all the sensors assigned to this relay will cause the relay to de-actuate.</p>
Average OFF	<p>Only works in Averaging Mode</p> <p>See Average ON above</p>
Actuate on Fault	<p>If it’s set to “YES”, any sensor or AI with OFFLINE Fault will cause the relay actuate</p>

On Delay	Delay on Make. For each relay a separate time delay may be set up to 9999 seconds before an alarm condition will cause the relay to actuate. Default is 10 seconds
Off Delay	Delay on Break. For each relay a separate time delay may be set up to 9999 seconds before a return to a non-alarming signal condition will cause the relay to de-actuate. Default is 10 seconds
Assigned Input	Define which inputs assigned to the relay

5.3.10 Buzzer/Strobe/Horn Setup

Click buzzer/strobe/horn list item will enter below configuration screen.

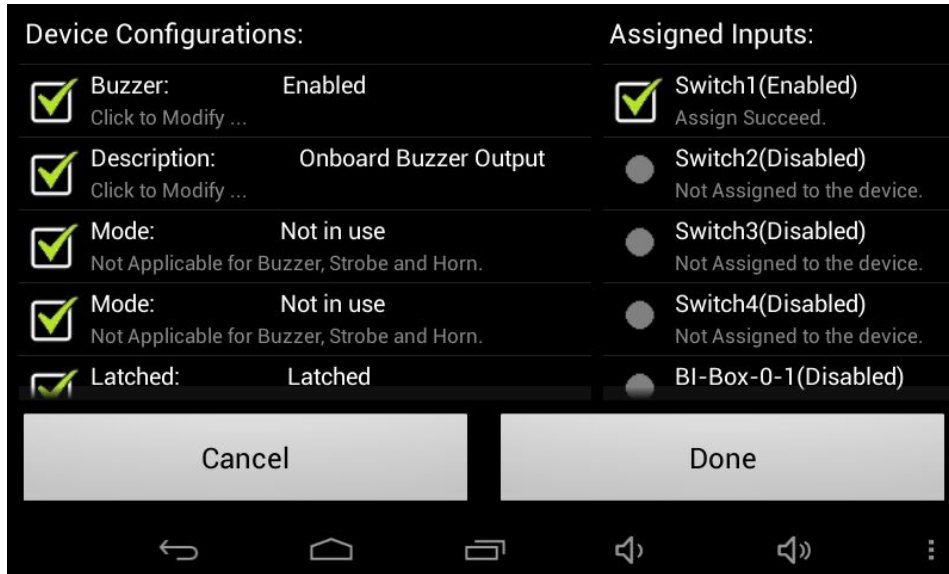

Buzzer	Description
Enable/Disable	Q-Controller only monitor and control enabled devices
Description	Description for this relay
Latched	<ul style="list-style-type: none"> • Latched • Non-Latched <p>The Latched Buzzer will be latched in actuate status until acknowledged by the button [Reset Latched RLY] on the Monitoring Screen or Switch Input with Reset Latched Relay Action</p>
Mode	<ul style="list-style-type: none"> • Voting Mode • Averaging Mode <p>For details see Relay Setup</p>
Voting Number	For details see Relay Setup

Average ON	For details see Relay Setup
Average OFF	For details see Relay Setup
Actuate on Fault	For details see Relay Setup
On Delay	For details see Relay Setup
Off Delay	For details see Relay Setup
Assigned Input	Define which inputs assigned to the buzzer

5.3.11 AO (Analog Output) Setup

Click AO-Box list item will enter below configuration screen.

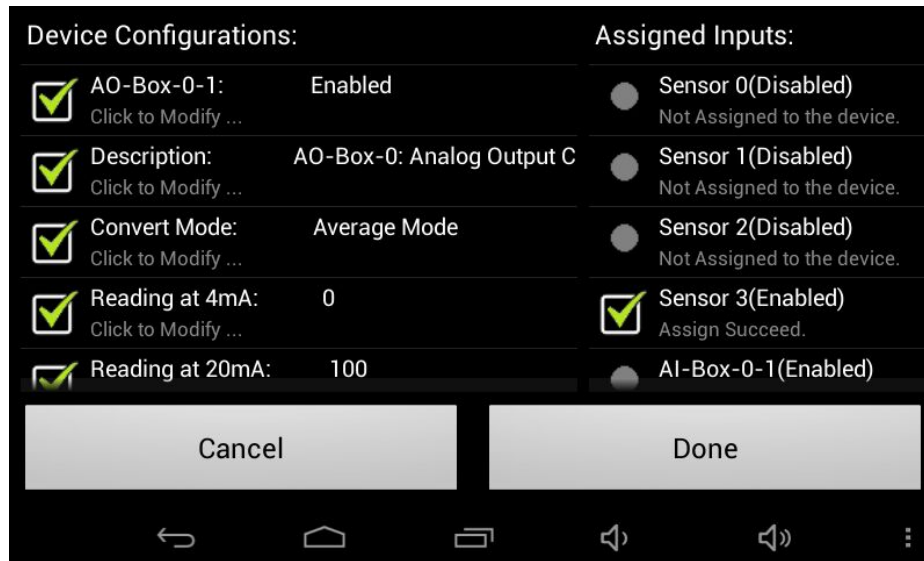

AO-Box	Description
Enable/Disable	Q-Controller only monitor and control enabled devices
Description	Description for this channel of AO-Box
Convert Mode	<ul style="list-style-type: none"> • Average Mode • Peak Mode <p>Analog outputs may work with sensors and analog inputs. It's allowed to assign more than one input per output channel. The inputs could be averaged or taken the peak among the inputs as the value to convert output current.</p>
Reading at 4mA	Assign a concentration for both the 4.0 milliamp signal, and the 20 milliamp signal. You may assign a larger concentration for 4.0 milliamps than for 20 milliamps; the Q-Controller will still stretch a straight line signal between the two points.
Reading at 20mA	See above
Assigned Input	Define which inputs assigned to the AO channel

5.4 Module Address Setting

The remote modules are designed to allow expandability for control to the Q-Controller. Controlled over the 4x RS-485 Sensor Port they allow flexibility in installation and wiring. They operate from 24 VAC/VDC and may be powered via the same power of the Q-Controller or directly from a local power source.

Each module is addressed as a module number from 0 to 15/31. The module address is defined on a four or five position dipswitch on the circuit card.

Name: BI-Box-Module Address-Channel#

AI-Box-Module Address-Channel#

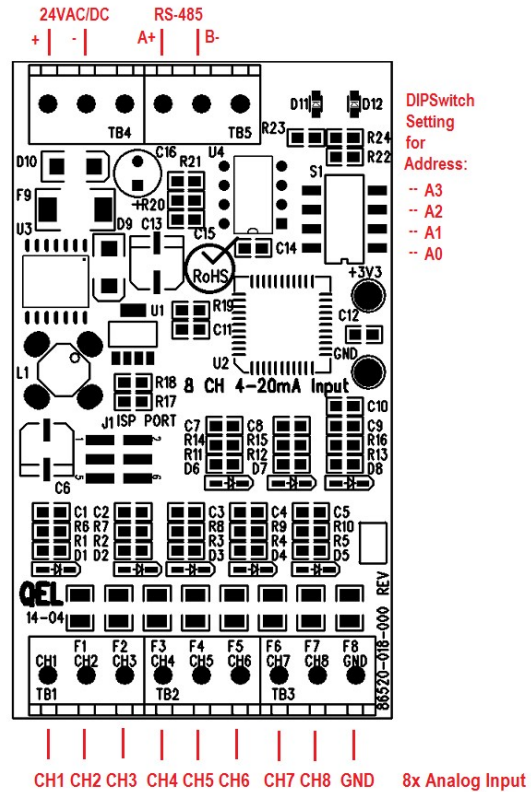
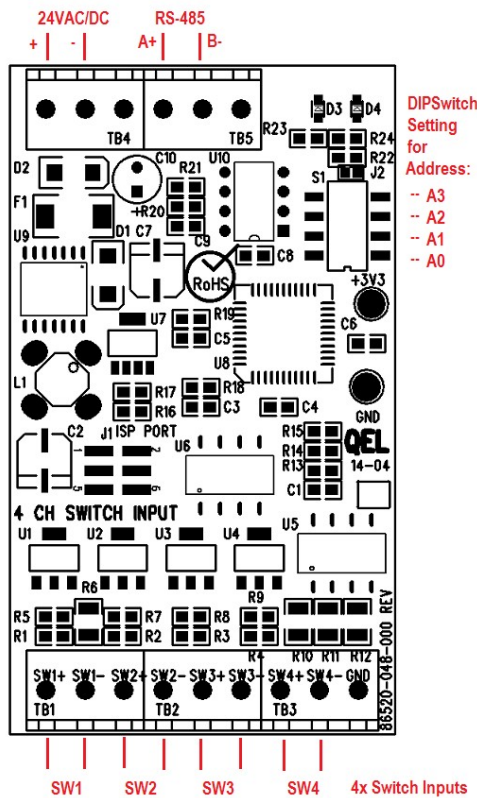

Name: RO-Box-Module Address-Channel#

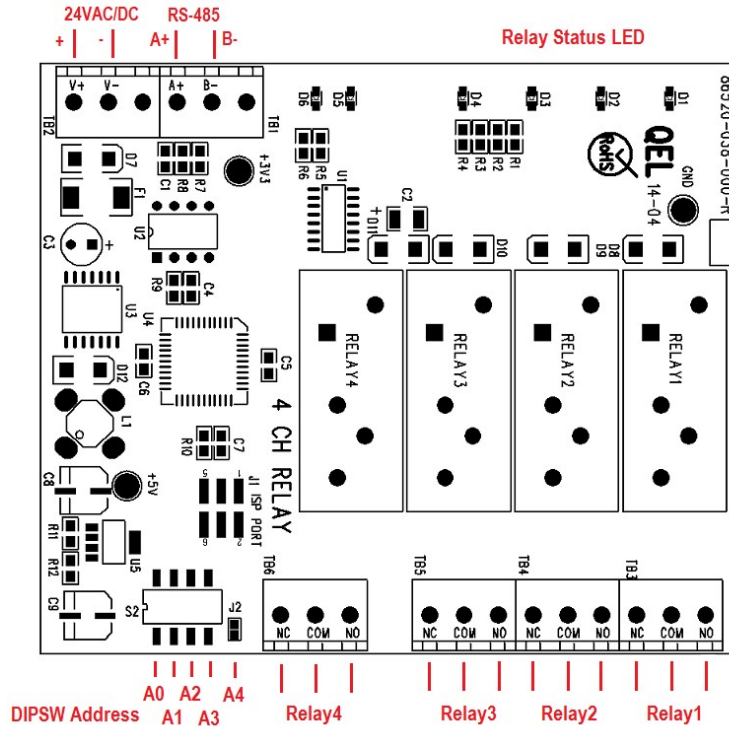

Name: AO-Box-Module Address-Channel#

J2= OPEN means A0= OFF

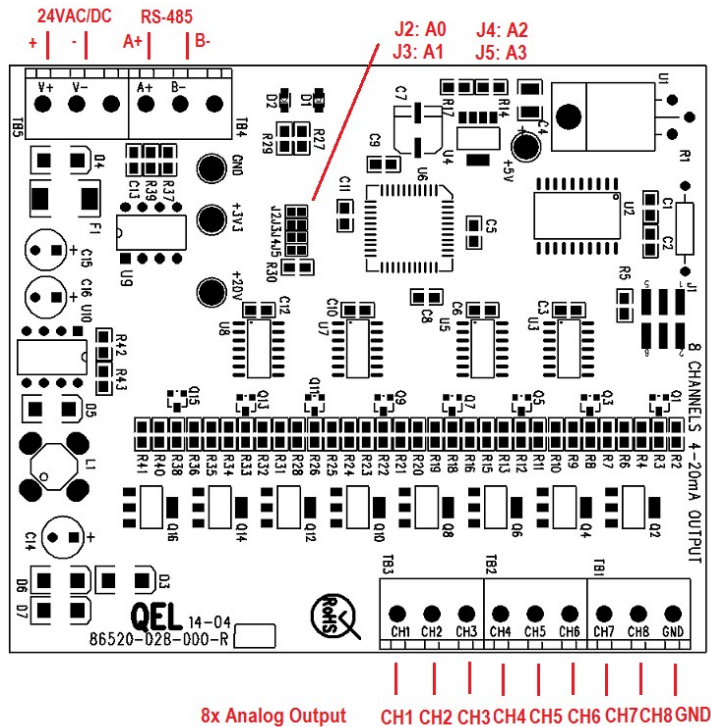

The following table indicates the relationships.

Module Address	Dip Switch Setting				
	A0	A1	A2	A3	J2
0	OFF	OFF	OFF	OFF	Open
1	ON	OFF	OFF	OFF	Open
2	OFF	ON	OFF	OFF	Open
3	ON	ON	OFF	OFF	Open
4	OFF	OFF	ON	OFF	Open
5	ON	OFF	ON	OFF	Open
6	OFF	ON	ON	OFF	Open
7	ON	ON	ON	OFF	Open
8	OFF	OFF	OFF	ON	Open
9	ON	OFF	OFF	ON	Open
10	OFF	ON	OFF	ON	Open
11	ON	ON	OFF	ON	Open
12	OFF	OFF	ON	ON	Open
13	ON	OFF	ON	ON	Open
14	OFF	ON	ON	ON	Open
15	ON	ON	ON	ON	Open
16	OFF	OFF	OFF	OFF	Closed
17	ON	OFF	OFF	OFF	Closed
18	OFF	ON	OFF	OFF	Closed
19	ON	ON	OFF	OFF	Closed
20	OFF	OFF	ON	OFF	Closed
21	ON	OFF	ON	OFF	Closed
22	OFF	ON	ON	OFF	Closed
23	ON	ON	ON	OFF	Closed
24	OFF	OFF	OFF	ON	Closed
25	ON	OFF	OFF	ON	Closed
26	OFF	ON	OFF	ON	Closed
27	ON	ON	OFF	ON	Closed
28	OFF	OFF	ON	ON	Closed
29	ON	OFF	ON	ON	Closed
30	OFF	ON	ON	ON	Closed
31	ON	ON	ON	ON	Closed

Module AI-Box and AO-Box do not have J2 on-board, as their valid address is from 0 to 15. Every Module address is set to 0 as factory default.

5.5 Monitoring Mode

After Setup the remote device and modules, click the tab [Monitoring] to enter to monitoring screen.

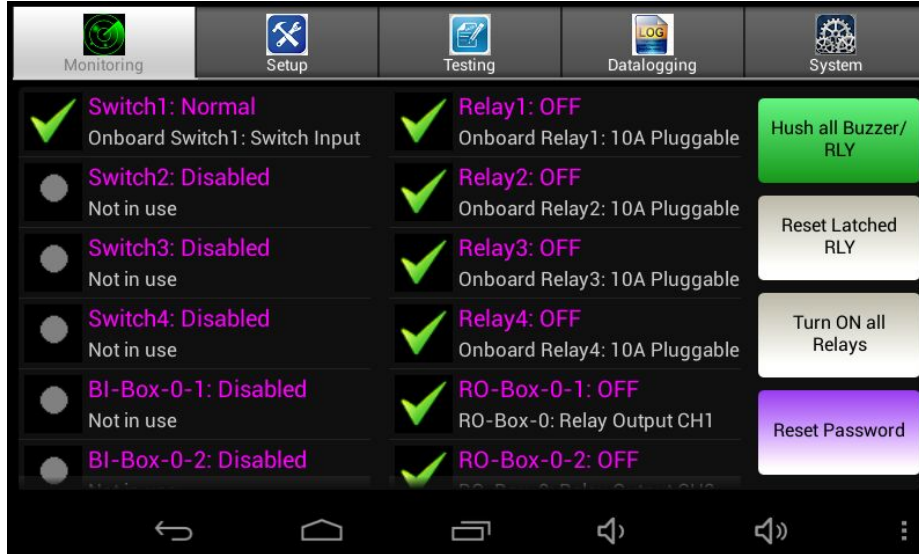

On-board switch input, on-board relay/buzzer/strobe/horn output and all remote modules are real time monitored in the screen.

Click on each item, you can view the running statuses and its program configuration.

There are four buttons on the right of the screen:

Button	Description
Hush all Buzzer/RLY	Press this button to silence the buzzer/horn and all buzzer style relays
Reset Latched RLY	Press this button to acknowledge a latched condition, all latched relays for which the alarm condition has been removed will reset. If the alarm condition (e.g. high gas concentration) is still present the relay(s)/buzzer will not reset.
Turn ON all Relays	This is quick testing in the field. All relays and buzzer/horn will be actuated.
Reset Password	To reset password A factory code is needed to unlock and reset the password to factory default password 4321

5.6 Testing Mode

Click the tab [Testing] to enter to Testing screen.

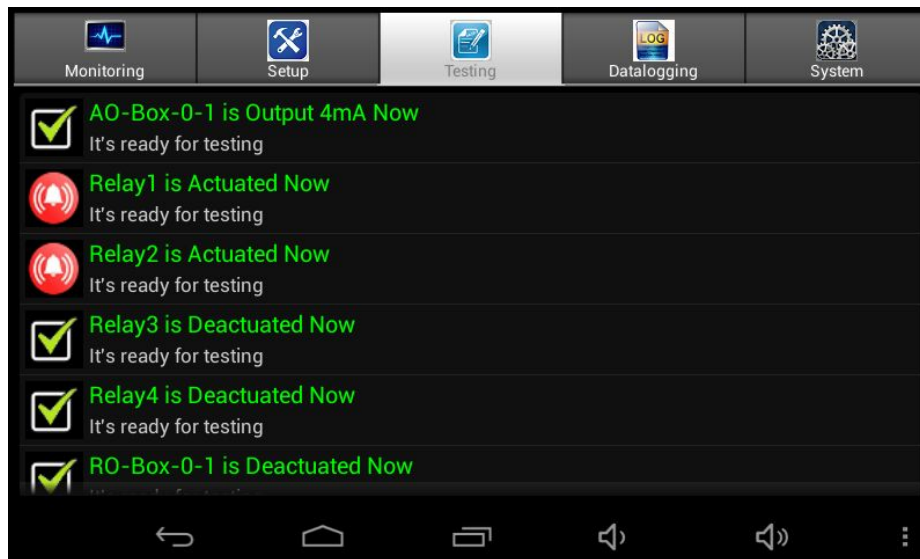

For system installation testing, it is necessary to force relay, buzzer and strobe actions.

The Testing Mode only works to the output devices, such as 4-20mA Output Module, Relays, and Buzzer/Strobe/Horn.

Click on each item, you can manually actuate or reset the device for testing.

Note that while not in the Monitoring Mode, all normal monitoring operations stop.

5.7 Datalogging Mode

Click the tab [Datalogging] to enter to Datalogging screen.

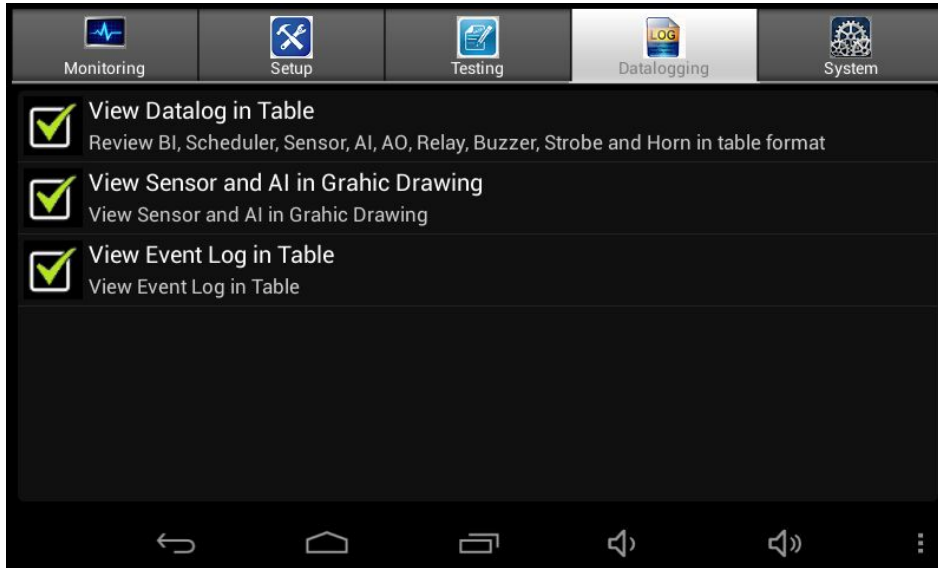

5.7.1 View Datalog in Table

Start Date:	End Date:	Left Form:	Left CH:	Right Form:	Right CH:	Quit
09/25/2014	09/25/2014	BI & SCH	All	RO & RZ	All	

Device	Status	DateTime
Switch1	OFF	00:00:00 09/25/2014
BI-Box-0-3	OFF	00:00:00 09/25/2014
BI-Box-0-4	OFF	00:00:00 09/25/2014
Switch1	OFF	01:00:00 09/25/2014
BI-Box-0-3	OFF	01:00:00 09/25/2014
BI-Box-0-4	OFF	01:00:00 09/25/2014
Switch1	OFF	02:00:00 09/25/2014
BI-Box-0-3	OFF	02:00:00 09/25/2014
BI-Box-0-4	OFF	02:00:00 09/25/2014
Switch1	OFF	03:00:01 09/25/2014
BI-Box-0-3	OFF	03:00:01 09/25/2014
BI-Box-0-4	OFF	03:00:01 09/25/2014

Device	Status	DateTime
Relay1	Latched	00:00:00 09/25/2014
Relay2	OFF	00:00:00 09/25/2014
Relay3	OFF	00:00:00 09/25/2014
Relay4	OFF	00:00:00 09/25/2014
RO-Box-0-1	OFF	00:00:00 09/25/2014
RO-Box-0-2	OFF	00:00:00 09/25/2014
RO-Box-0-3	OFF	00:00:00 09/25/2014

There are two forms or tables in the screen.

You can choose the start date, end date and what kind of device you want to see in the two forms. If there is no value or status changed on the channel, it will show the channel's value or status every hour.

Click button [Quit] to exit to previous screen.

5.7.2 View Sensor and AI in Graphic Drawing

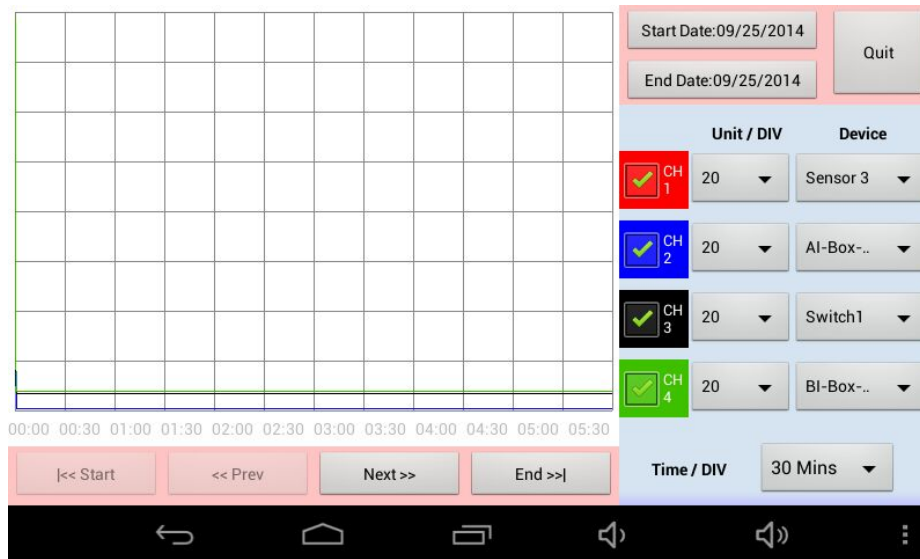

Click button [Quit] to exit to previous screen.

5.7.3 View Event Log in Table

Start Date:	End Date:	Left Form:	Allleft CH:	Right Form:	Allright CH:	Quit
09/25/2014	09/25/2014	RI & SCH	A#	RO & R7	A#	
DateTime	Event					
09:39:07 09/25/2014	QC-MMI in Setup Mode.					
09:41:20 09/25/2014	QC-MMI in Monitoring Mode.					
09:59:22 09/25/2014	QC-MMI in Setup Mode.					
09:59:30 09/25/2014	QC-MMI in Monitoring Mode.					
09:59:36 09/25/2014	QC-MMI in System Mode.					
09:59:47 09/25/2014	QC-MMI in Monitoring Mode.					
10:06:38 09/25/2014	QC-MMI in Setup Mode.					
10:07:31 09/25/2014	QC-MMI in Monitoring Mode.					
10:07:47 09/25/2014	QC-MMI in Setup Mode.					
10:08:38 09/25/2014	QC-MMI in Monitoring Mode.					
10:13:08 09/25/2014	QC-MMI in Setup Mode.					
10:13:59 09/25/2014	QC-MMI in Monitoring Mode.					

Click button [Quit] to exit to previous screen.

6 MODBUS Protocol Supported By Q-Controller

For Modbus protocol, please contact ACI.

7 Troubleshooting Hints

Q-Controller has advanced features and functions. Before assuming that unexpected behavior is caused by a system defect or breakdown, the operator should use this manual to become thoroughly familiar with the Q-Controller operation. This troubleshooting guide is intended as an aid in identifying the cause of unexpected behavior and determining whether the behavior is due to normal operation or an internal or external problem.

SYMPTOMS	PROBABLE CAUSE	SUGGESTED SOLUTION
LCD Display does not come on	<ul style="list-style-type: none"> No power supply LCD has problem Program has crashed 	<ul style="list-style-type: none"> Check power / ground connections Change LCD Reprogram
RS-485 RX LED or TX LED constantly ON	<ul style="list-style-type: none"> RS-485 bus connection has problem RS-485 Driver is damaged Remote Device side RS-485 Driver has problem 	<ul style="list-style-type: none"> Disconnect the Cable to isolate the problem Replace Driver on main board Replace RS-485 Driver in Remote Device
Q-Controller reports "Vote no Sensor!" or "AV no Sensor!"	<ul style="list-style-type: none"> No sensor was assigned to the output (relay or analog output) 	<ul style="list-style-type: none"> Assign sensor to the output
Q-Controller reports "Sensor Offline" or "Relay Offline"	<ul style="list-style-type: none"> Comm setting is wrong Connection is wrong Remote Device is in Fault End-of-line matching resistors are not properly set. 	<ul style="list-style-type: none"> Check the remote baud rate in Q-Controller System Setting is same as the baud rate in Digital Sensor or M-Relay. Check connection between Q-Controller and Digital Sensor and M-Relay. Make sure all have power on and no shorts or opens in wiring. Be certain that polarity for RS-485 connections is correct. A-A and B-B Examine remote devices Review end-of-line resistor settings

WARRANTY STATEMENT

All ACI equipment is warranted against defects in material and workmanship for a period of two years from date of shipment with the following exceptions:

Electrochemical Sensors (Toxic) Six Months

Catalytic Sensors (Combustible) One Year

Full warranty information can be found on ACI's website:
<http://www.workaci.com/sites/default/files/warranty.pdf>

LIMITED LIABILITY

All ACI systems shall be installed by a qualified technician/electrician and maintained in strict accordance with data provided for individual systems in the form of installation/maintenance manuals. ACI assumes no responsibility for improper installation, maintenance, etc., and stresses the importance of reading all manuals. ACI shall not be responsible for any liability arising from auxiliary interfaced equipment nor any damage resulting from the installation or operation of this equipment.

ACI's total liability is contained as above with no other liability expressed or implied as the purchaser is entirely responsible for installation and maintenance of systems.

This warranty is in lieu of all other warranties, expressed or implied, and no representative or person is authorized to represent or assume for ACI any liability in connection with the sales of our products other than that set forth herein.

NOTE: Due to on-going product development, ACI reserves the right to change specifications without notice and will assume no responsibility for any costs as a result of modifications.

For further information or assistance, contact:

AUTOMATION COMPONENTS, INC.

2305 Pleasant View Road

Middleton, Wisconsin

Tel: (888) 967-5224

Fax: (608) 831-7407

Web: workaci.com