

H931



Hawkeye® 931

Split-Core Current Transducer with Relay, 4-20mA Output

Installer's Specifications

Sensor Power	30mA (max.)@12-30VDC
Insulation Class	600VAC RMS
Frequency Range	50/60Hz
Temperature Range	-15° to 60°C (5° to 140°F)
Humidity Range	10 - 90% RH, non-condensing
Accuracy	±2% full scale from 10% to 100% (selected range)
Response Time	2 sec.
Terminal Block Maximum Wire Size	14 AWG
Terminal Block Torque (nominal)	4 in-lbs (0.45 N-m)
Agency Approvals	UL 508 open device listing

Do not use LED status indicators as evidence of applied voltage

DANGER

HAZARD OF ELECTRIC SHOCK, EXPLOSION, OR ARC FLASH

- Follow safe electrical work practices. See NFPA 70E in the USA, or applicable local codes.
- This equipment must only be installed and serviced by qualified electrical personnel.
- Read, understand and follow the instructions before installing this product.
- Turn off all power supplying equipment before working on or inside the equipment.
- Use a properly rated voltage sensing device to confirm power is off.
DO NOT DEPEND ON THIS PRODUCT FOR VOLTAGE INDICATION
- Only install this product on insulated conductors.

Failure to follow these instructions will result in death or serious injury.

NOTICE

- This product is not intended for life or safety applications.
- Do not install this product in hazardous or classified locations.
- The installer is responsible for conformance to all applicable codes.
- Mount this product inside a suitable fire and electrical enclosure.

QUICK INSTALL

1. Disconnect and lock out power to the conductor to be monitored.

Plan the installation:

Locate a mounting surface for the removable mounting bracket that will allow the monitored conductor to pass through the iris, or "window" when it is installed and keep the product at least 1/2" from any uninsulated conductors. Determine cable routing for the controller connection, allowing wiring to reach the mounting location. If using with a variable frequency drive, the sensor must be located on the LINE side.

2. Install mounting bracket
Drill holes to mount the bracket to the chosen surface using the included screws.
3. Set the desired amperage range (30, 60, or 120 Amps).
4. Wire the output connections between the sensor and the controller (4-20mA).
5. Snap the sensor over the wire to be monitored and clip the assembly to the mounting bracket.
6. Scale the controller software to match the sensor's output.
7. Close up and power up.

DIMENSIONS

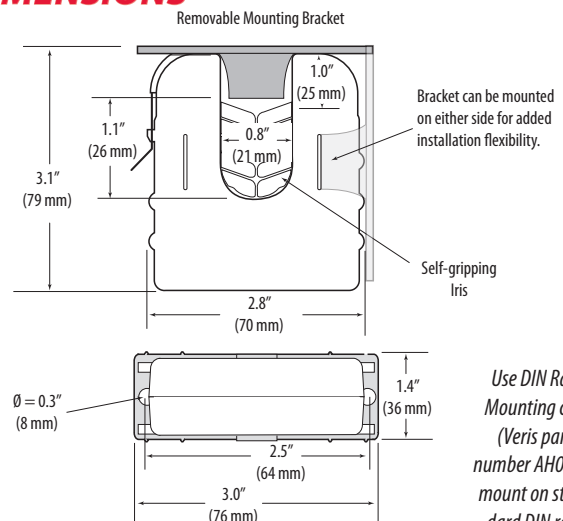
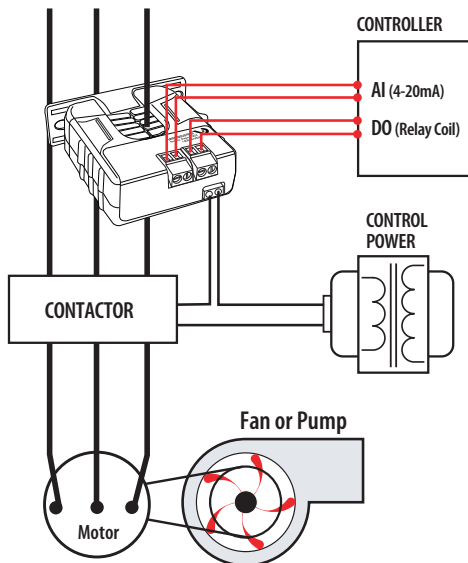

Use DIN Rail Mounting clip (Veris part number AH01) to mount on standard DIN rail.

OPERATION

The H931 is a current-sensitive device that monitors current (amperage) in any of three field-selectable ranges; zero-to-thirty, zero-to-sixty, or zero-to-one hundred twenty amperes. These ranges represent the maximum current which can be applied to the monitored conductor. The H931 transforms the monitored current into a 4-20mA output suitable for connection to building controllers or other appropriate data acquisition equipment. It is also equipped with a command relay.

The H931 housing offers unprecedented mounting flexibility. The mounting bracket can be attached in three different places. Additionally, the bracket is compatible with the Veris AH01 DIN Rail clip, allowing DIN mounting.

NOTES

For load currents greater than sensor maximum rating:

Use a 5 Amp (H68xx series) Current Transformer (CT) as shown.

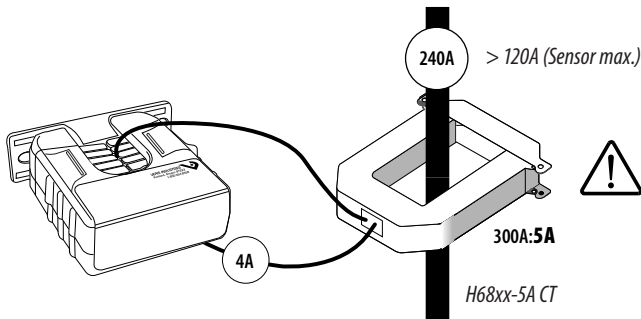

! DANGER: 5A CTs can present hazardous voltages. Install CTs in accordance with manufacturer's instructions. Terminate the CT secondary before applying current.

CAUTION

RISK OF EQUIPMENT DAMAGE

- Derate the product's maximum current for the number of turns through the sensing window using the following formula.

$$\text{Rated Max. Amps} \div \text{Number of Turns} = \text{Max. monitored Amps}$$
 e.g. : $100A \div 4 \text{ Turns} = 25 \text{ Amps max. in monitored conductor}$
- Failure to follow these instructions can result in overheating and permanent equipment damage.

For load currents less than sensor minimum rating:

Wrap the monitored conductor through the center hole and around the sensor body to produce multiple turns through the "window." This increases the current measured by the transducer.

Controller must be programmed to account for the extra turns. e.g., if four turns pass through the sensor (as shown) the normal controller reading must be divided by 4.

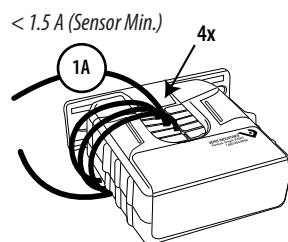

WIRING

Sinking Panel (+ Common)

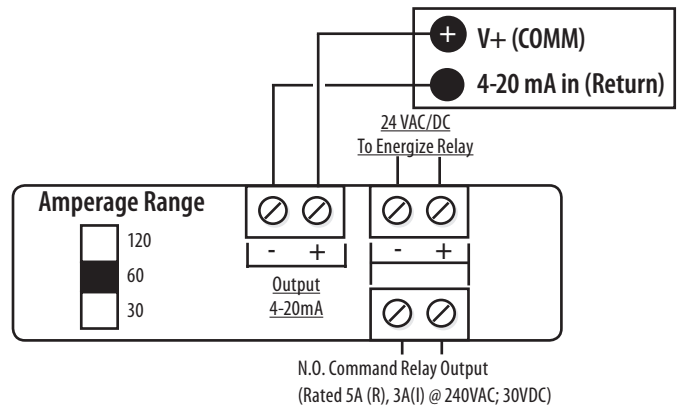

Sourcing Panel (- Common)

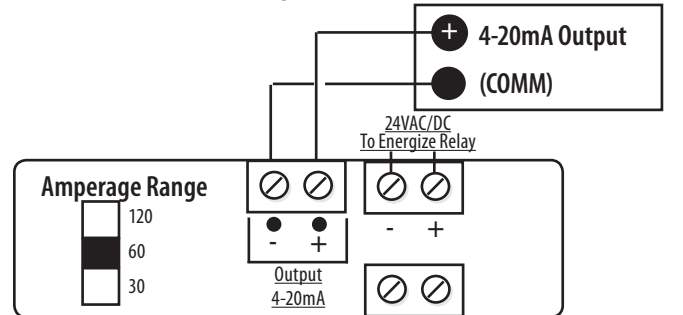

External Power Voltage Input

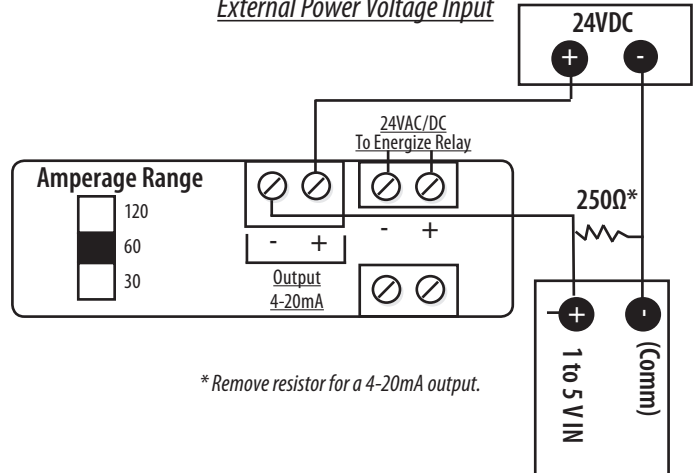

SCALING

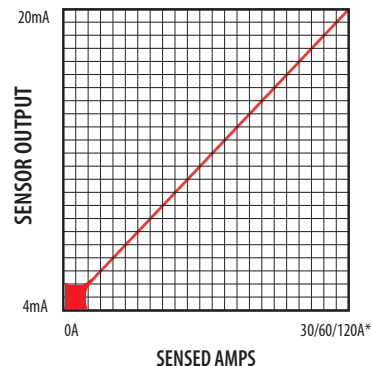

*Factory calibrated ranges selected with the amperage range switch