

H906



Hawkeye® 906

Split-Core Current Switch, Adjustable Trip Point, N.C. Status Output

Installer's Specifications

Sensor Power	5-30VDC
Insulation Class	600VAC RMS (UL), 300VAC RMS (CE)
Frequency Range	50/60Hz
Temperature Range	-15° to 60°C (5° to 140°F)
Humidity Range	10-90% RH non-condensing
Hysteresis	10% of setpoint, typical
Off-State Leakage	34µA@5VDC, 200µA@30VDC
On-State Voltage Drop	1.9VDC max.@0.1A
Amperage Range	2.5 - 135A Continuous
Output	N.C. 0.1A@30VDC, polarity sensitive
Safety	UL 508, IEC 61010-1: 2001 CAT III

Specification Note: For CE compliance, conductor shall be insulated according to IEC 61010-1:2001, Installation Category III or equivalent. The product design provides for basic insulation only.

QUICK INSTALL

1. Disconnect and lock out power to the conductor to be monitored.
2. Plan the installation:
Locate a mounting surface for the removable mounting bracket that will allow the monitored conductor to pass through the iris, or "window" when it is installed and keep the product at least 1/2" (13mm) from any uninsulated conductors (CE). Determine cable routing for the controller connection, allowing wiring to reach the mounting location.
3. Install mounting bracket
Drill holes to mount the bracket to the chosen surface using the included screws.
4. Wire the output connections between the sensor, the controller (solid-state contact), and external power supply.
5. Snap the sensor over the wire to be monitored and clip the assembly to the mounting bracket.
6. Calibrate the sensor (see page 2) with the load running normally.

DANGER

HAZARD OF ELECTRIC SHOCK, EXPLOSION, OR ARC FLASH

- Follow safe electrical work practices. See NFPA 70E in the USA, or applicable local codes.
- This equipment must only be installed and serviced by qualified electrical personnel.
- Read, understand and follow the instructions before installing this product.
- Turn off all power supplying equipment before working on or inside the equipment.
- Use a properly rated voltage sensing device to confirm power is off.
- **DO NOT DEPEND ON THIS PRODUCT FOR VOLTAGE INDICATION**
- Only install this product on insulated conductors.

Failure to follow these instructions will result in death or serious injury.

NOTICE

- This product is not intended for life or safety applications.
- Do not install this product in hazardous or classified locations.
- The installer is responsible for conformance to all applicable codes.
- Mount this product inside a suitable fire and electrical enclosure.

WIRING EXAMPLE

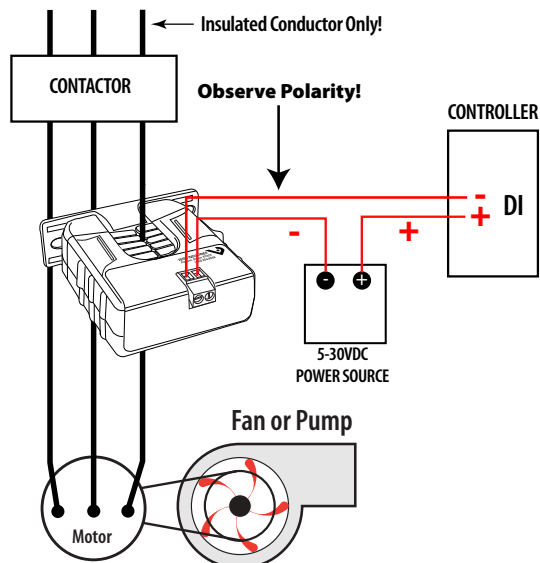

DIMENSIONS

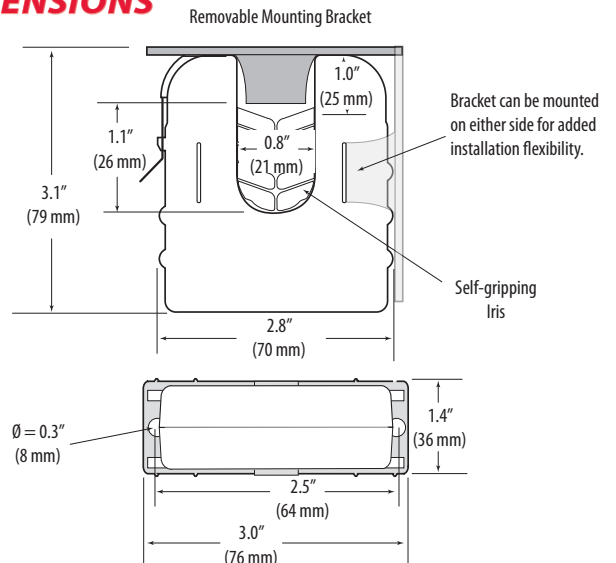

OPERATION

The H906 is a current-sensitive switching device that monitors current (amperage) in the conductor passing through it. A change in amperage in the monitored conductor that crosses the switch (setpoint) threshold plus the hysteresis value will cause the resistance of the FET status output to change state, similar to the action of a mechanical switch. In this model, the setpoint is adjustable through the action of a twenty (20) turn potentiometer (see the Calibration section). The status output is suitable for connection to building controllers or other appropriate data acquisition equipment operating at up to 30 volts. The H906 requires a 5-30VDC external power supply to generate its output.

The H906 housing offers unprecedented mounting flexibility. The mounting bracket can be attached in three different places. Additionally, the bracket is compatible with the Veris AH01 DIN Rail clip, allowing DIN mounting.

NOTES

For load currents greater than sensor maximum rating:

Use a 5 Amp (H68xx series) Current Transformer (CT) as shown.

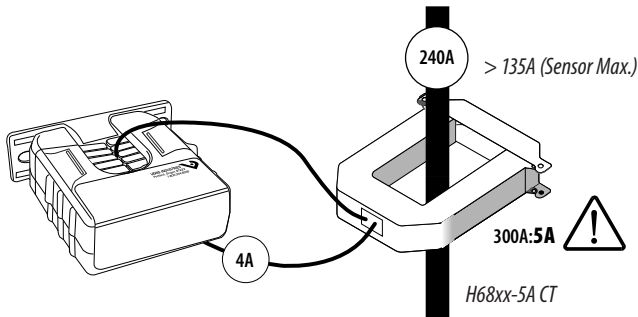

DANGER: 5A CTs can present hazardous voltages. Install CTs in accordance with manufacturer's instructions. Terminate the CT secondary before applying current.

CAUTION

RISK OF EQUIPMENT DAMAGE

- Derate the product's maximum current for the number of turns through the sensing window using the following formula.

$$\text{Rated Max. Amps} \div \text{Number of Turns} = \text{Max. monitored Amps}$$
 e.g. : $100A \div 4 \text{ Turns} = 25 \text{ Amps max. in monitored conductor}$
- Failure to follow these instructions can result in overheating and permanent equipment damage.

For load currents less than sensor minimum rating:

Wrap the monitored conductor through the center hole and around the sensor body to produce multiple turns through the "window." This increases the current measured by the transducer.

Controller must be programmed to account for the extra turns. e.g., if four turns pass through the sensor (as shown) the normal controller reading must be divided by 4.

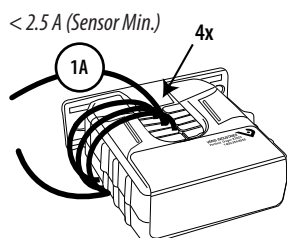

CALIBRATION

Before beginning calibration, establish normal load conditions.

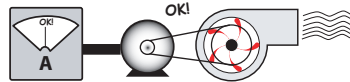

Then choose either A or B below.

A. To monitor under-current (belt loss, coupling shear, status)

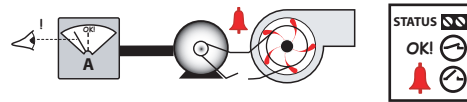

1. Turn setpoint screw clockwise until Status CLOSED LED turns ON.



2. Slowly turn the screw counter-clockwise until the Status OPEN LED just turns ON.

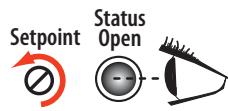

3. Turn the screw an additional 1/4 turn counter-clockwise for operational margin.

B. To monitor over-current (mechanical problems, seized impeller)

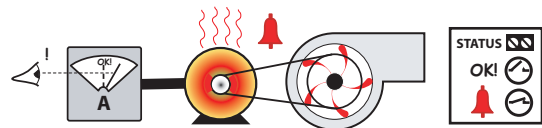

1. Turn setpoint screw counter-clockwise until Status OPEN LED turns ON.

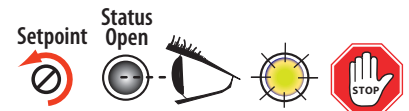

2. Slowly turn the setpoint screw clockwise until the Status CLOSED LED just turns ON.

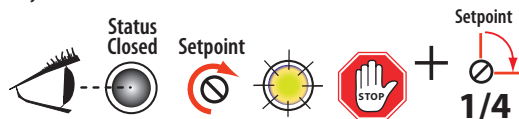

3. Turn the setpoint screw an additional 1/4 turn clockwise for operational margin.

TROUBLESHOOTING

Problem	Solution
No Reading at Controller	<ul style="list-style-type: none"> • Check sensor calibration (see above) • Check for control voltage at sensor (5VDC < voltage < 30V) • Check for amperage in monitored conductor (> 2.5A) • Assure that sensor core mating surfaces are clean and that the core clamp is completely closed
Setpoint screw has no stops	The setpoint screw has a slip-clutch at both ends of its travel to avoid damage. Twenty turns CCW will reset the sensor to be most sensitive. Repeat calibration above.
Both LEDs are lit	Setpoint screw is too far clockwise. See solution above.