

# H800



# Hawkeye® 800

## Solid-Core Go/No Go Current Switch

### Installer's Specifications

|                       |   |
|-----------------------|---|
| Amperage Range        | 0.25-200A Continuous                                  |
| Sensor Supply Voltage | Induced from monitored conductor                      |
| Isolation             | 600VAC rms. (UL) 300VAC (CE)                          |
| Temperature Range     | -15° to 60°C  |
| Humidity Range        | 10-90% RH non-condensing                              |
| Status Output Ratings | N.O. 1.0A@30VAC/DC non-polarity sensitive             |
| Off-state leakage     | 0 (open switch represents 1 + MEG ohms of resistance) |

Specification Note: For CE compliance, conductor shall be insulated according to IEC 61010-1:2001, Installation Category III or equivalent. The unit design provides for basic insulation only.

## ⚠ DANGER ⚡

### HAZARD OF ELECTRIC SHOCK, EXPLOSION, OR ARC FLASH

- Follow safe electrical work practices. See NFPA 70E in the USA, or applicable local codes.
- This equipment must only be installed and serviced by qualified electrical personnel.
- Read, understand and follow the instructions before installing this product.
- Turn off all power supplying equipment before working on or inside the equipment.
- Use a properly rated voltage sensing device to confirm power is off.
- **DO NOT DEPEND ON THIS PRODUCT FOR VOLTAGE INDICATION**
- Only install this product on insulated conductors.

**Failure to follow these instructions will result in death or serious injury.**

## NOTICE

- This product is not intended for life or safety applications.
- Do not install this product in hazardous or classified locations.
- The installer is responsible for conformance to all applicable codes.
- Mount this product inside a suitable fire and electrical enclosure.

## QUICK INSTALL

1. Plan the installation:
  - Locate a mounting surface for the removable mounting bracket that will allow the monitored conductor to pass through the iris, or "window" when it is installed and keep the product at least ½" from any uninsulated conductors (CE). Determine cable routing for the controller connection, allowing wiring to reach the mounting location.
2. Install mounting bracket
  - Drill holes to mount the bracket to the chosen surface using the included screws.
3. Wire the output connections between the sensor and the controller (solid-state contact).
4. Route the wire to be monitored through the product iris and clip the assembly to the mounting bracket.
5. Close up and power up!

## DIMENSIONS

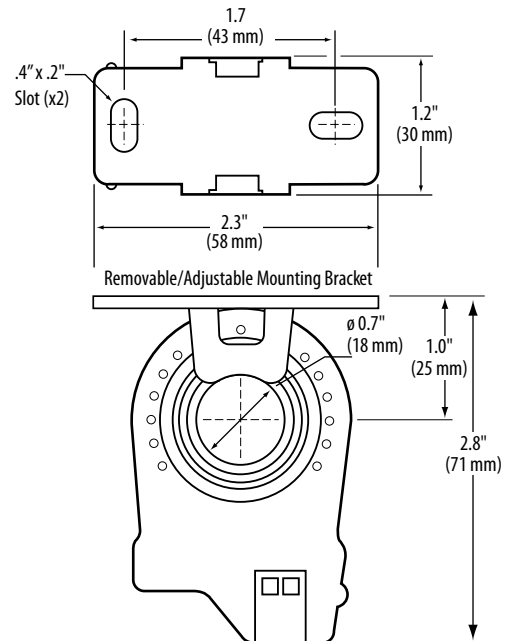

### Wiring Example

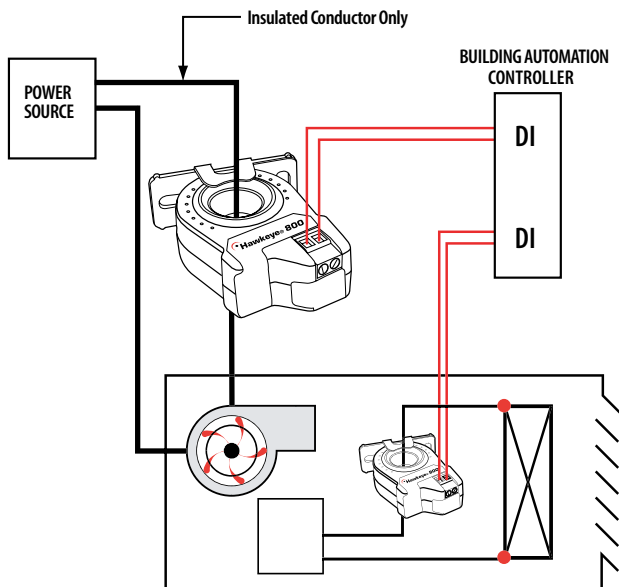

**OPERATION**

The H800 is a current-sensitive switching device which monitors current (amperage) in the conductor passing through it. A change in amperage in the monitored conductor which crosses the switch threshold will cause the resistance of the status output to change state, similar to the action of a mechanical switch. In this model, the threshold is fixed at 250mA AC max. The status output is suitable for connection to building controllers, or other appropriate data acquisition equipment operating at up to 30 volts. The H800 requires no external power supply to generate its output.

**TROUBLESHOOTING**

| Problem                  | Solution  |
|--------------------------|---|
| No Reading at Controller | <ul style="list-style-type: none"> <li>• Check for control voltage at sensor (&lt;30V)</li> <li>• Check for amperage in monitored conductor (&gt; 0.25A)</li> </ul> |

**NOTES**

**For load currents greater than sensor maximum rating:**

Use a 5 Amp (H681x series) Current Transformer (CT) as shown.

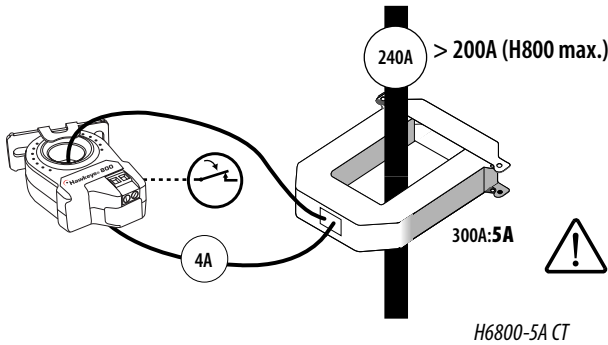

 **DANGER: 5A CTS CAN PRESENT HAZARDOUS VOLTAGES. INSTALL CTS IN ACCORDANCE WITH MANUFACTURER'S INSTRUCTIONS. TERMINATE THE CT SECONDARY BEFORE APPLYING CURRENT.**

**CAUTION**

**RISK OF EQUIPMENT DAMAGE**

- Derate the product's maximum current for the number of turns through the sensing window using the following formula.  

$$\text{Rated Max. Amps} \div \text{Number of Turns} = \text{Max. monitored Amps}$$
 e.g. : 100A ÷ 4 Turns = 25 Amps max. in monitored conductor
- Failure to follow these instructions can result in overheating and permanent equipment damage.

**For load currents less than sensor minimum rating:**

Wrap the monitored conductor through the center hole and around the sensor body to produce multiple turns through the "window." This increases the current measured by the transducer.

- Controller must be programmed to account for the extra turns. e.g., if four turns pass through the sensor (as shown) the normal threshold current must be divided by 4.

