

# Installation Instructions HAWKEYE 738

## Solid Core Adjustable Current Status Sensor with Command Relay AC/DC switching output

**VERIS INDUSTRIES, INC.**

PORTLAND, OREGON USA

Toll Free in USA 1.800.354.8556

Tel USA 1.503.598.4564

FAX USA 1.503.598.4664

http://www.veris.com email: sales@veris.com



### INSTALLATION

#### !CAUTION!

- This product is not intended for life or safety applications.
- Installing sensors in an energized motor control center or on any energized conductor can be hazardous.

Severe injury or death can result from electrical shock during contact with high voltage conductors or related equipment. Disconnect and lock-out all power sources prior to installation.

Applications shown are suggested means of installing sensors, but it is the responsibility of the installer to ensure that the installation is in compliance with all national and local codes. Installation should be attempted only by individuals familiar with codes, standards, and proper safety procedures for high-voltage installations.

1. **Ensure power conductor to be monitored is disconnected and locked out from the power source!**

2. Install the adjustable mounting bracket to the back of the motor control center. The sensor may be located at any point on the conductor between the motor and the motor starter.

3. Align to permit the conductor to fit through the hole. Slide the conductor through the center hole in the sensor and connect the conductor to the lugs on the motor starter.

**Note:** Low (<1 amp) and high (>135 amps) applications may require special installation:

a. Low amperage (<1 amp FLA) - to provide adequate current, wrap conductor through the center hole and around the sensor body to produce multiple turns and increase flow. Measured current = Actual Current x Number of turns.

b. High amperage (>135 amp FLA) - current flows in excess of 135 amps require the use of an appropriately sized external current transformer. Install the external CT on the conductor and run the CT secondary wire through the sensor. **CAUTION:** CTs can contain hazardous voltages. Install CTs in accordance to manufacturers' specifications and instructions.

4. Wire as shown below. Use copper conductors only for command relay output. Tighten relay output terminals to 3.5 lb. in.torque **Note:** Testing the solid-state output of this sensor with a digital ohm meter may yield inaccurate, but relative readings of switching (i.e., 6 Meg Ohms.) Use an Analog VOM for readings similar to loop.

#### Status output is not polarity sensitive

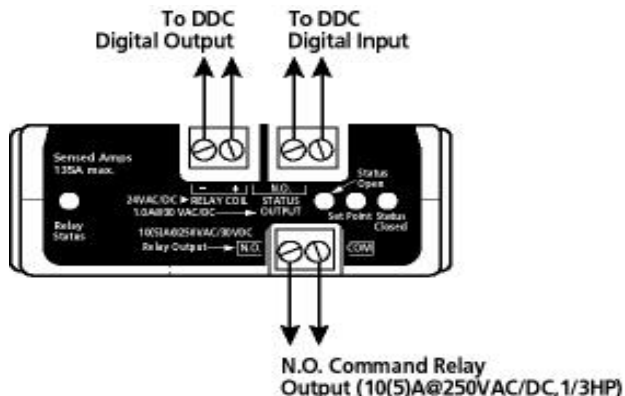

### CALIBRATION

Orient the current switch so the status output terminal is facing you and follow method number 1 or 2 below.

1. For under current status indication: (Belt loss, fan & pump status)

- Turn the set point screw clockwise until the status closed LED goes out and the status open LED comes on.
- Turn the set point screw counter-clockwise until the status open LED goes out and the status closed LED comes on.
- Turn the set point screw ¼ turn counter-clockwise.
- The sensor is now calibrated to provide indication of current flows below normal full load amps.

Output Status:

Normal: Output closed

Alarm: Output open

2. For over current status indication: (Locked rotor)

- Turn the set point screw counter-clockwise until the status open LED goes out and the status closed LED comes on.
- Turn the set point screw clockwise until the status closed LED goes out and the status open LED comes on.
- Turn the set point screw clockwise ¼ turn
- The sensor is now calibrated to provide indication of current flows above normal full load amps

Output Status:

Normal: Output open

Alarm: Output closed

#### !CAUTION!

Status indicators of this device should not be relied on to determine whether or not the monitored conductor is connected to a power source. Doing so may result in injury or death from electrical shock.

**For technical assistance, please call 1-800-354-8556**

### SPECIFICATIONS

Amperage Ratings.....	1 to 135A continuous
Sensor Supply Voltage....	Induced from monitored conductor
Isolation.....	600VAC rms
Sealing.....	N.E.M.A. 1
Temperature range.....	-15 to 60°C
Humidity range.....	0-95% non-condensing
Relay output.....	10(5)A@250VAC/30VDC, 1/3HP
Relay coil.....	24VAC/DC ; 10mA nom
Status Output.....	N.O. 1.0A @ 30 VAC/DC