

H10F



Hawkeye® 10F

Split-Core, Auto-calibration, Current Switch

Installer's Specifications

Amperage Range	3.5-100A Continuous
Sensor Supply Voltage	Induced from monitored conductor
Isolation	600VAC rms.(UL); 300VAC rms (CE)
Temperature Range	-15° to 60° C
Humidity Range	10-90% RH non-condensing
Status Output Ratings	N.O. 1.0A@30VAC/DC not polarity sensitive
On-state Resistance	≤1.0 ohms
Off-state Resistance	≥1 megohm
Frequency Range	50/60Hz
Setpoint Target Range	±20% window around learned setpoint, nominal@25 °C*
Alarm Reset Range	±15% window around learned setpoint, nominal@25 °C*
Setpoint Calibration Learn Period	Self-learning on 5 sec pushbutton actuation, 30 sec. learn period

NORMAL-to-ALARM Status Output Delay 1 second max.
 ALARM-to-NORMAL Status Output Delay 30 seconds nominal**

*For best performance, monitor 5A or more current. At currents less than 5A, these ranges are approximate.

**If current switch experiences a momentary loss of power, 30 second delay may or may not apply.

Specification Note: For CE compliance, conductor shall be insulated according to IEC 61010-1:2001, Installation Category III or equivalent. The unit design provides for basic insulation only.

⚠ DANGER ⚡

HAZARD OF ELECTRIC SHOCK, EXPLOSION, OR ARC FLASH

- Follow safe electrical work practices. See NFPA 70E in the USA, or applicable local codes.
- This equipment must only be installed and serviced by qualified electrical personnel.
- Read, understand and follow the instructions before installing this product.
- Turn off all power supplying equipment before working on or inside the equipment.
- Use a properly rated voltage sensing device to confirm power is off.
DO NOT DEPEND ON THIS PRODUCT FOR VOLTAGE INDICATION
- Only install this product on insulated conductors.

Failure to follow these instructions will result in death or serious injury.

NOTICE

- This product is not intended for life or safety applications.
- Do not install this product in hazardous or classified locations.
- The installer is responsible for conformance to all applicable codes.
- Mount this product inside a suitable fire and electrical enclosure.

QUICK INSTALL

1. Plan the installation:
Locate a mounting surface for the removable mounting bracket that will allow the monitored conductor to pass through the iris, or "window" when it is installed and keep the product at least ½" from any uninsulated conductors (CE). Determine cable routing for the controller connection, allowing wiring to reach the mounting location.
2. Install mounting bracket
Drill holes to mount the bracket to the chosen surface using the included screws.
3. Wire the output connections between the sensor and the controller (solid-state contact).
4. Snap the sensor over the wire to be monitored and clip the assembly to the mounting bracket.
5. Close up and power up!

DIMENSIONS

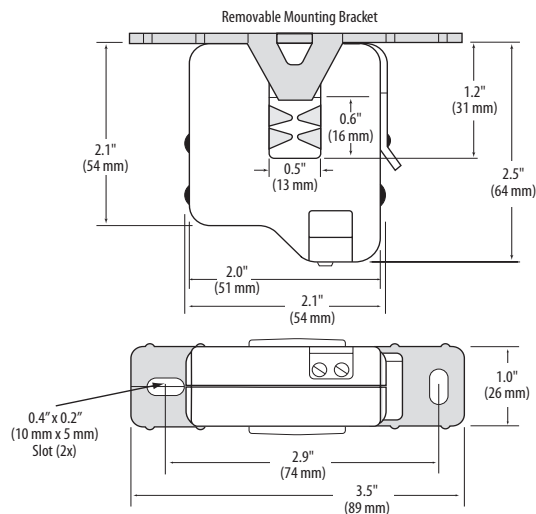

Wiring Example

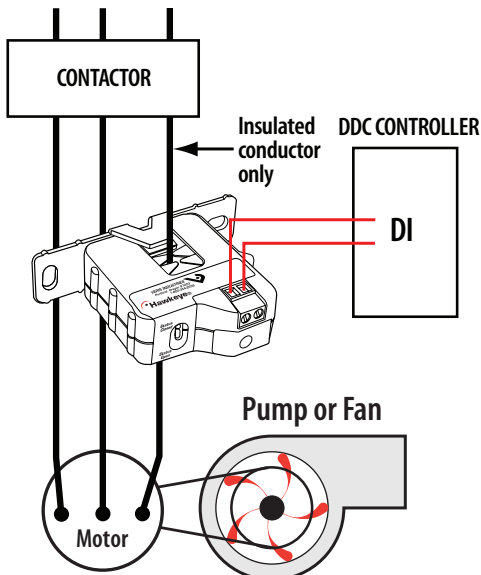

OPERATION

The H10F is a over-current and under-current monitor device intended for use with a PLC or other system controller. The current switch learns the nominal amperage on the line, then monitors for amperage changes greater than +/-20% of the learned value. If the amperage goes out of the normal range, the current switch changes output state, raising an alarm in the system controller. This alarm state will persist until the amperage comes back to within +/-15% of the learned value for 30 seconds to ensure that the system has truly returned to normal operation. The status output is suitable for connection to system controllers or other data acquisition equipment operating at up to 1A and 30VDC. The H10F requires no external power supply to generate its output.

NOTES

For load currents greater than sensor maximum rating:
Use a 5 Amp (H681x series) Current Transformer (CT) as shown.

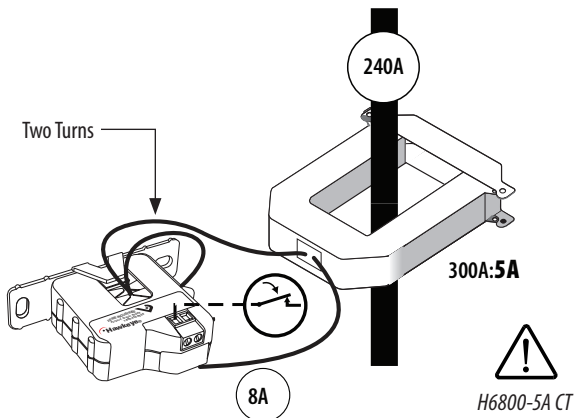

⚠ DANGER: 5A CTS CAN PRESENT HAZARDOUS VOLTAGES. INSTALL CTS IN ACCORDANCE WITH MANUFACTURER'S INSTRUCTIONS. TERMINATE THE CT SECONDARY BEFORE APPLYING CURRENT.

CAUTION

RISK OF EQUIPMENT DAMAGE

- Derate the product's maximum current for the number of turns through the sensing window using the following formula.
Rated Max. Amps ÷ Number of Turns = Max. monitored Amps
e.g. : 100A ÷ 4 Turns = 25 Amps max. in monitored conductor
- Failure to follow these instructions can result in overheating and permanent equipment damage.

For load currents less than sensor minimum rating:

Wrap the monitored conductor through the center hole and around the sensor body to produce multiple turns through the "window." This increases the current measured by the switch.

- Controller must be programmed to account for the extra turns. e.g., if four turns pass through the sensor (as shown) the normal controller reading must be divided by 4.

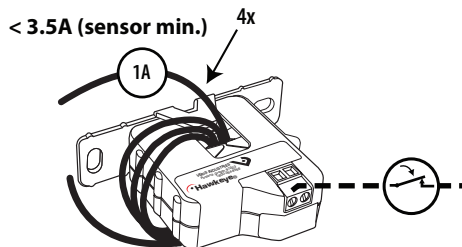

CALIBRATION

Establish normal load conditions.

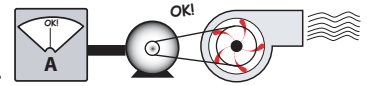

First Time Power Up: No calibration needed, unit will automatically learn normal load when powered.

To manually learn normal load:

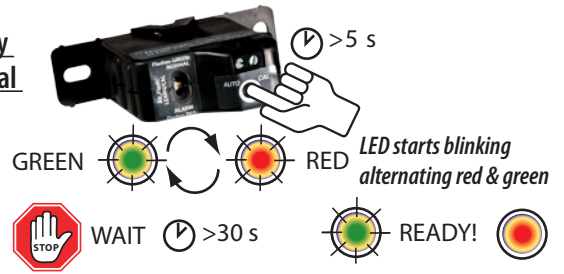

When only the GREEN LED blinks, the unit is measuring normal current.

To reset automatic learn normal load:

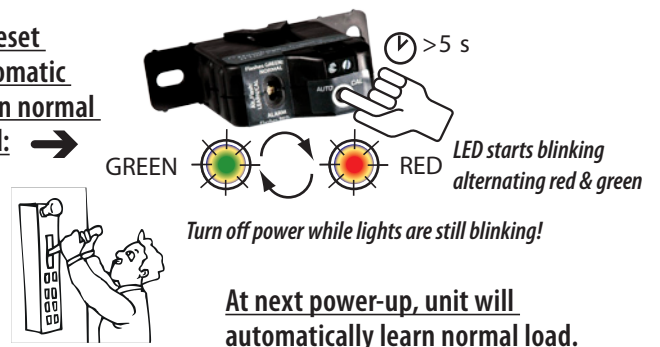

At next power-up, unit will automatically learn normal load.

OPERATING STATES

Mode	Output Status	LED Indication
LEARN (30 sec)	Closed ($\leq 1 \Omega$)	Alternating Red/Green
NORMAL	Closed ($\leq 1 \Omega$)	Blinking Green
ALARM	Open ($\geq 1 m\Omega$)	Blinking Red

Status Output Logic Sense:
 • Open = No primary current or primary current out of range,
 • Closed = Primary current within range
Note: Status contacts may close momentarily when unit is initially recovering from an extended (typically longer than 10 seconds) power OFF state to an ALARM state.

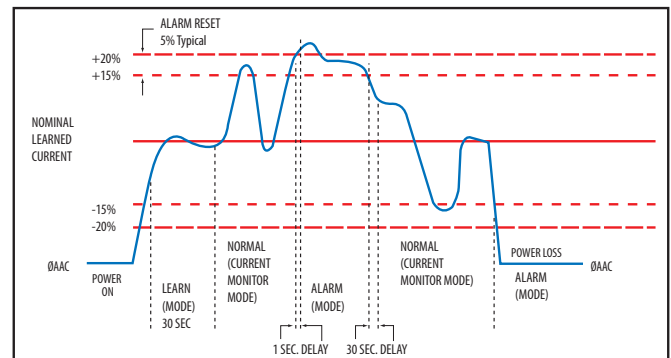

TROUBLESHOOTING

Problem	Solution
No Reading at Controller	<ul style="list-style-type: none"> • Check sensor calibration (see above) • Check for control voltage at sensor (<30V) • Check for amperage in monitored conductor (> 3.5A) • Assure that sensor core mating surfaces are clean and that the core clamp is completely closed