

MODEL	REF	CUSTOMER	HP	VOLTS	AMPS	HZ	RPM	ROTATION	CAT. NO	DESCRIPTION / REMARKS
K55HXTDM-8416	A100988	STANDARD	3/4	115	10.6	60	1075/4 SPD	C.CW LEAD END REV	5463	

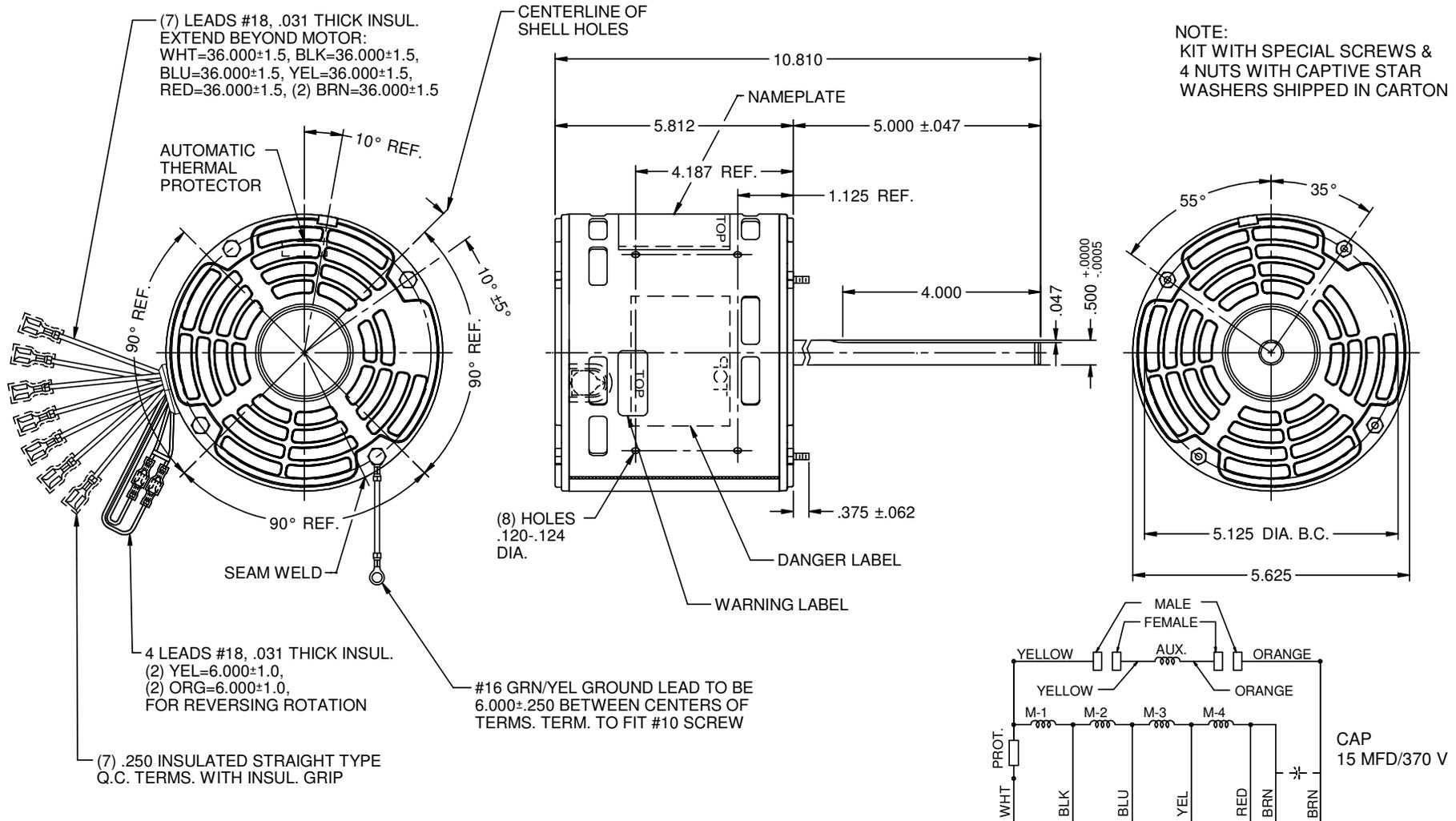

NIDEC MOTOR CORPORATION 16-Oct-18

REVISION RECORD FOR:	ECO: E32195
CREATED NEW DRAWING	
ISSUED BY:	F. GARCIA
ENGINEER APPROVED:	P. RODRIGUEZ

DIMENSIONS ARE FOR REFERENCE ONLY

UNLESS TOLERANCE IS SPECIFIED

NIDEC MOTOR CORPORATION			
INFORMATION DISCLOSED ON THIS DOCUMENT IS CONSIDERED PROPRIETARY AND SHALL NOT BE REPRODUCED OR DISCLOSED WITHOUT WRITTEN CONSENT OF NIDEC MOTOR CORPORATION			
TITLE			REVISION DATE:
CUSTOMER DETAIL DRAWING			16-OCT-18
CODE	ITEM NO.	REV	SHEET NUMBER
V02	823184	--	1 OF 3
			DWG SIZE
			B