

MODEL	REF	CUSTOMER	CUSTOMER PN	HP	VOLTS	AMPS	HZ	RPM	ROTATION	DESCRIPTION / REMARKS
K55HXHAB-2059	A2938-1	WHOLESALE - HAC	1679	1/10	227	0.51	60	810/675/500	CW LE REV.	

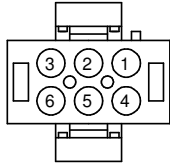
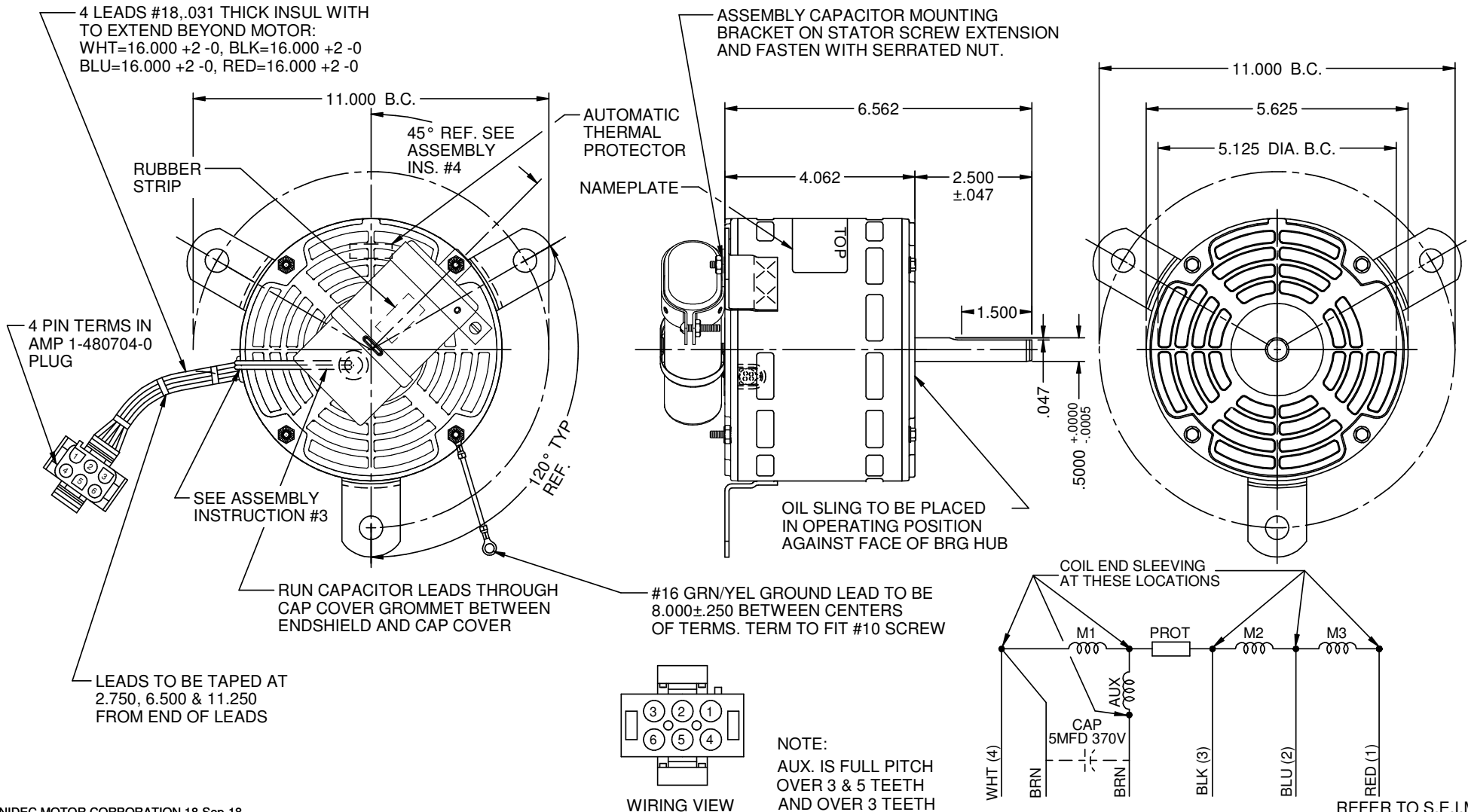

NIDEC MOTOR CORPORATION 18-Sep-18

REVISION RECORD FOR:	ECO E32155
NEW DRAWING CREATED.	
ISSUED BY:	I. GUTIERREZ
ENGINEER APPROVED:	P. RODRIGUEZ

DIMENSIONS ARE FOR REFERENCE ONLY

UNLESS TOLERANCE IS SPECIFIED

<b>NIDEC MOTOR CORPORATION</b>			
INFORMATION DISCLOSED ON THIS DOCUMENT IS CONSIDERED PROPRIETARY AND SHALL NOT BE REPRODUCED OR DISCLOSED WITHOUT WRITTEN CONSENT OF NIDEC MOTOR CORPORATION			
TITLE		CODE	ITEM NO.
CUSTOMER DETAIL DRAWING		V02	822733
		REV	SHEET NUMBER
		--	1 OF 3
		REVISION DATE:	DWG SIZE
		18-SEP-18	B