

MODEL	REF	CUSTOMER	HP	VOLTS	AMPS	HZ	RPM	ROTATION	CAT. NO.	DESCRIPTION / REMARKS
K48ZZTRW-4104	A20100	STANDARD	1/12	277	.69	60	1450/3 SPD	CCW LEAD END	1960	

REV. A

USE WITH A 5 MFD/370 VAC CAPACITOR

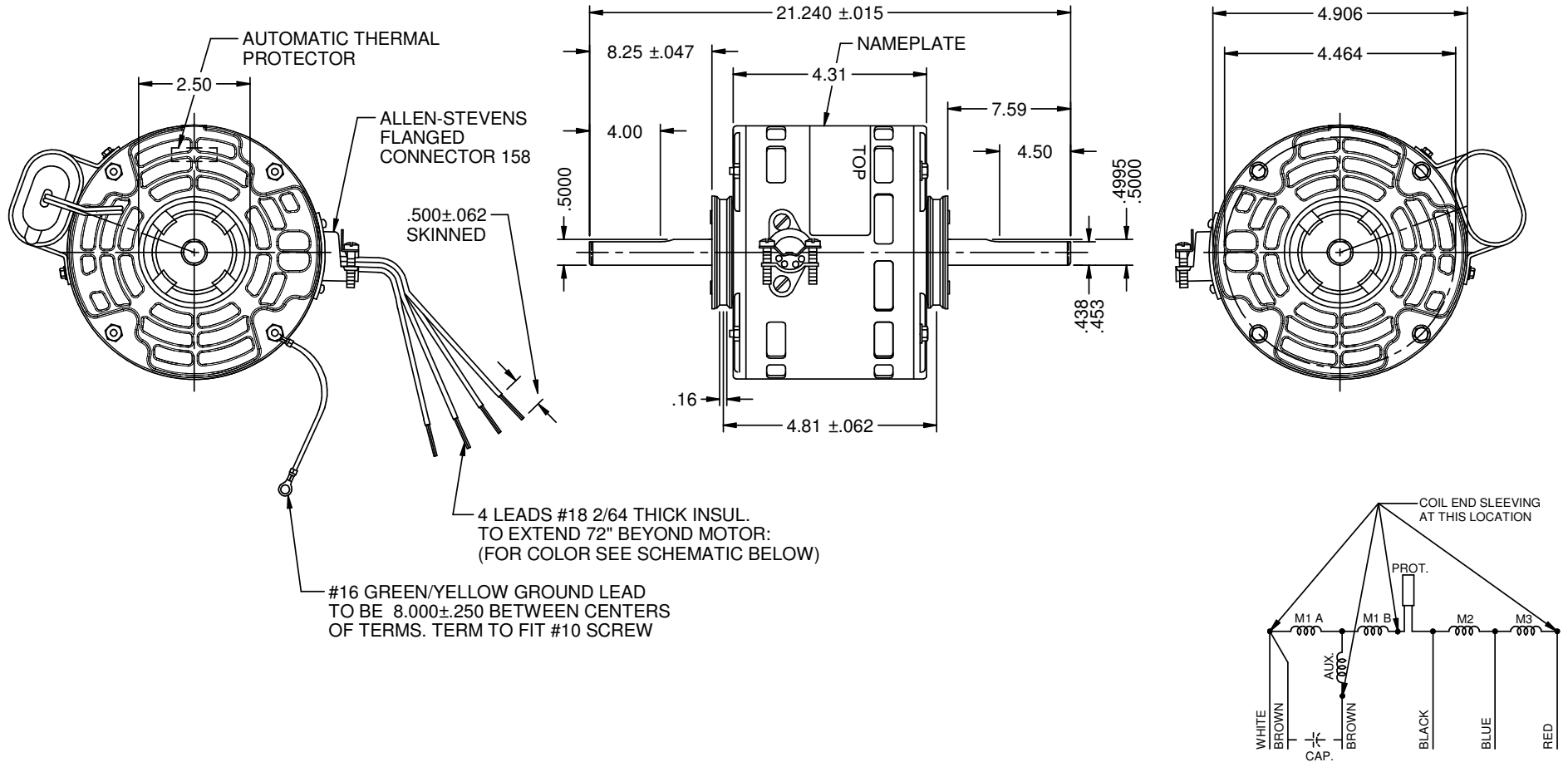

NIDEC MOTOR CORPORATION 22-May-18

REFER TO S.E.I.M. 24-1

REVISION RECORD FOR:	E31279
RPM CHANGED TO 1450/3 SPD.	
ISSUED BY:	E. REYES
ENGINEER APPROVED:	G. MEDINA

DIMENSIONS ARE FOR REFERENCE ONLY

UNLESS TOLERANCE IS SPECIFIED

NIDEC MOTOR CORPORATION

INFORMATION DISCLOSED ON THIS DOCUMENT IS CONSIDERED PROPRIETARY AND SHALL NOT BE REPRODUCED OR DISCLOSED WITHOUT WRITTEN CONSENT OF NIDEC MOTOR CORPORATION

REVISION DATE: 22-MAY-18

TITLE	CODE	ITEM NO.	REV	SHEET NUMBER	DWG SIZE
CUSTOMER DETAIL DRAWING	V02	815666	A	1 OF 3	B