

MODEL	REF	CUSTOMER	HP	VOLTS	AMPS	HZ	RPM	ROTATION	CUSTOMER PT. NO.	DESCRIPTION / REMARKS
K55HXPNF-2850		WHOLESALE HAC	3/4 - 1/5	115	8.1-3.1	60	1075	CCW LEAD END REV	3312	K55, HUB, BALL BRG, OPEN

7 LEADS #18, .031 THICK INSUL. TO EXTEND BEYOND MOTOR:
WHT=36.000+2-0, BLK=36.000+2-0, BLUE=36.000+2-0,
PUR=36.000+2-0, RED=36.000+2-0, BRN=36.000+2-0,
BRN/WHT=36.000+2-0.

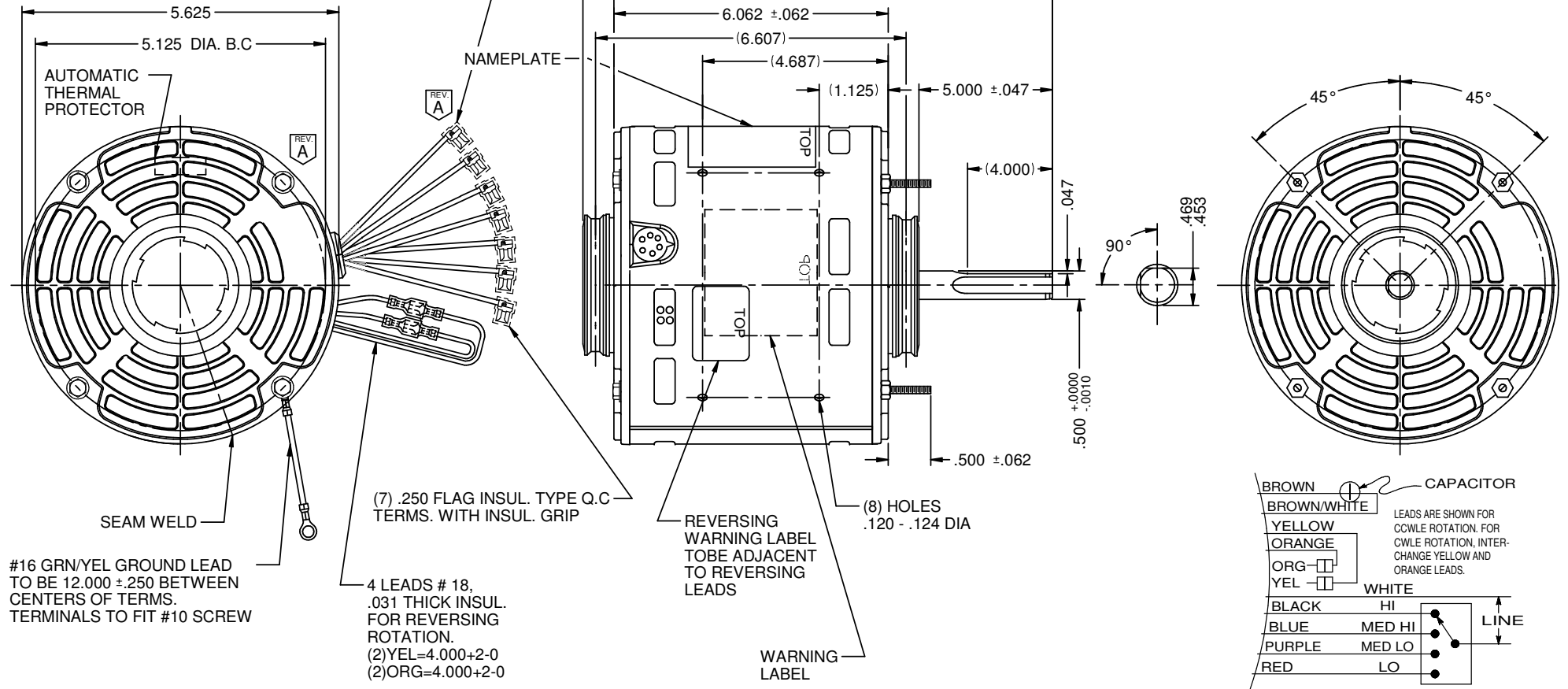

"SHIPPED DETACHED KIT ASSEMBLY"

NIDEC MOTOR CORPORATION 15-Mar-17

REFER TO S.E.I.M. 24-1

REVISION RECORD FOR:		DIMENSIONS ARE FOR REFERENCE ONLY		NIDEC MOTOR CORPORATION				
E28270		UNLESS TOLERANCE IS SPECIFIED		INFORMATION DISCLOSED ON THIS DOCUMENT IS CONSIDERED PROPRIETARY AND SHALL NOT BE REPRODUCED OR DISCLOSED WITHOUT WRITTEN CONSENT OF NIDEC MOTOR CORPORATION				
WAS CHANGED TERMINALS VIEW				TITLE		CODE	ITEM NO.	REVISION DATE:
WAS CHANGED SCREW VIEW LEAD END				CUSTOMER DETAIL DRAWING		V02	814584	15-MAR-17
ISSUED BY:	ENGINEER APPROVED:					REV	SHEET NUMBER	DWG SIZE
K. DE LA CERDA	J. RICE					A	1 OF 3	B