

CATALOG #	NIDEC MODEL	REVCOR NUMBER	FAN DIA. "D"	PITCH	A HUB WIDTH	G SCREW LOCATOR	W BLADE WIDTH	BORE DIA.	DESCRIPTION/REMARKS
US4A2234S	Z2980414200010L	607516	22	34	0.81	0.28	7.84	.500	CW
US4B2234S	Z2980414200020L	607517	22	34	0.81	0.28	7.84	.500	CCW

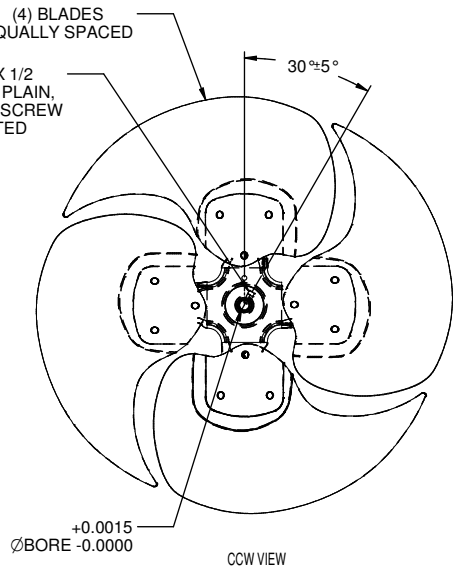
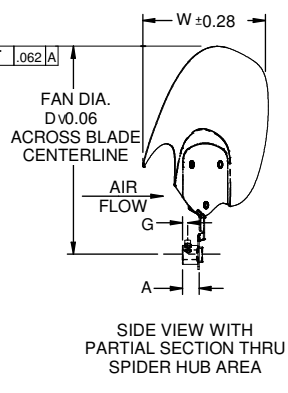
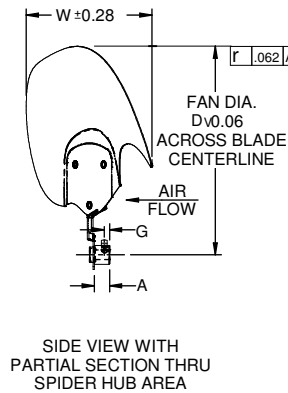
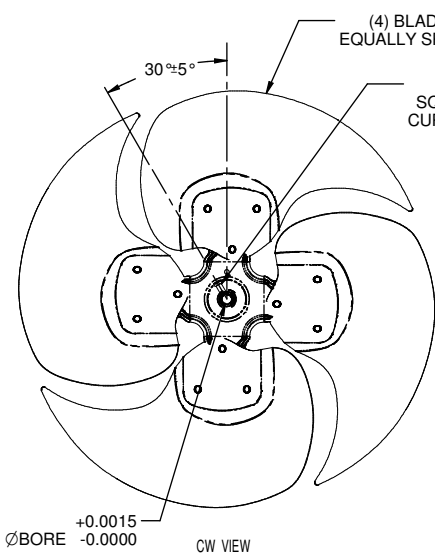

NIDEC MOTOR CORPORATION 08-OCT-15

REVISION RECORD FOR:

F24789

TOLERANCES ON DIMENSIONS (UNLESS OTHERWISE SPECIFIED):

INCHES
.XX = ±.010
.XXX = ±.005

mm

ANGLES X° ±1°

NIDEC MOTOR CORPORATION

INFORMATION DISCLOSED ON THIS DOCUMENT IS CONSIDERED PROPRIETARY AND SHALL NOT BE REPRODUCED OR DISCLOSED WITHOUT WRITTEN CONSENT OF NIDEC MOTOR CORPORATION

REVISION DATE: 18-FEB-16

ISSUED BY: H. PEÑA

ENGINEER APPROVED: T. BOURQUIN

TITLE: CUSTOMER DETAIL DRAWING

CODE: V02

ITEM NO.: 810033

REV: --

SHEET NUMBER: 1 OF 2

DWG SIZE: B

V02_NMCB (MAR-2014)

SOLIDEDGE