

MODEL	REF	CUSTOMER	HP	VOLTS	AMPS	HZ	RPM	ROTATION	CATALOG #	DESCRIPTION / REMARKS
K55HXRHE-2140	C40931-X4	WHOLESALE HAC	1/2	115	7.3	50/60	1075/3 SPD	CCW LE	NAL1056	-----

KIT WITH BRACKET ASSEMBLY RINGS
SCREWS AND NUTS TO BE INCLUDED
IN CARTON BOX.

AUTOMATIC THERMAL
PROTECTOR

SEAM WELD
LOCATION

(2) .250 FLAG
TYPE Q.C TERMS

#16 GREEN GROUND LEAD
TO BE 24.0 ±1 BETWEEN CENTERS
OF TERMINALS, TERMINAL TO FIT
#10 SCREW

6 LEADS #18, 0.031 THICK INSUL.
TO EXTEND BEYOND MOTOR:
WHT=36.0±1, BLUE=36.0±1
BLK=36.0±1, RED=36.0±1
BRN=36.0±1, BRN/WHT STRIPE 36.0 ±1
LEADS TO BE PROTECTED WITH GROMMET.

REV
A

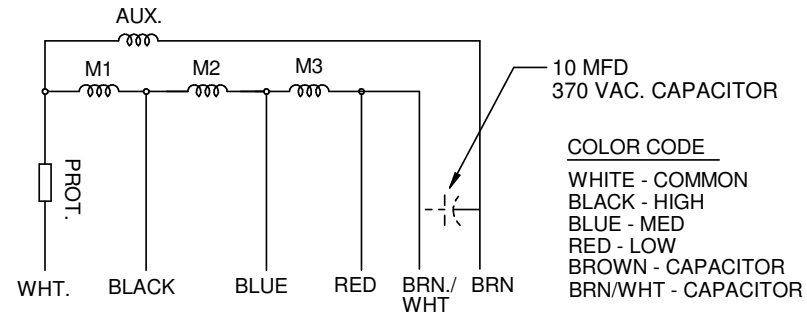
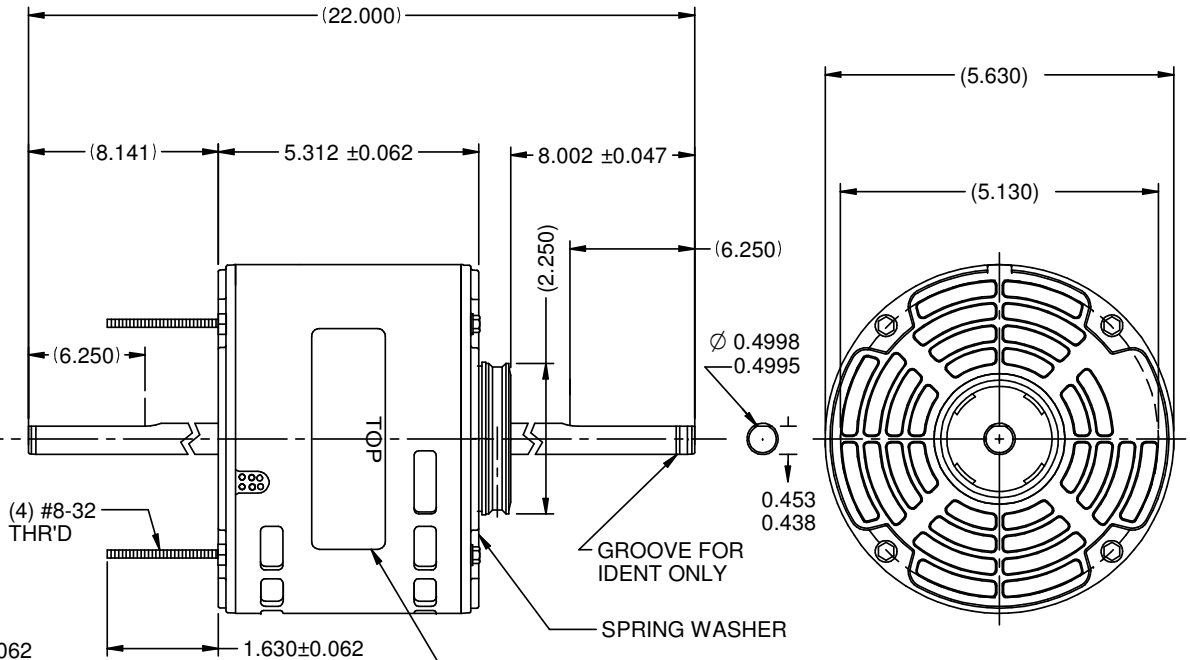

NIDEC MOTOR CORPORATION 24-Feb-16

REVISION RECORD FOR:

ECO-E25005

DELETED NOTE "FIGURES TO BE PRINTED ON LEADS"

TOLERANCES ON DIMENSIONS
(UNLESS OTHERWISE SPECIFIED)

INCHES
.XX = ±.010
.XXX = ±.005

mm

ANGLES X° = ±1°

NIDEC MOTOR CORPORATION

INFORMATION DISCLOSED ON THIS DOCUMENT IS CONSIDERED PROPRIETARY AND SHALL NOT BE
REPRODUCED OR DISCLOSED WITHOUT WRITTEN CONSENT OF NIDEC MOTOR CORPORATION

REVISION DATE:

24-FEB-16

ISSUED BY: C.ALMAGUER

ENGINEER APPROVED: A.LOZANO

TITLE
CUSTOMER DETAIL DRAWING

CODE
V02

ITEM NO.
806704

REV
A

SHEET
NUMBER
1 OF 3

DWG
SIZE
B

REFER TO S.E.I.M. 24-1