

VAR	MODEL	CUSTOMER	CAT. NO.	A	B	C	D	HP	VOLTS	SF	AMPS	HZ	RPM	CONN VOLTS	PROT.	DESCRIPTION / REMARKS
001	T55JXCRK-1539	USEM	D13CPA1P49	9.94	-----	-----	-----	1/3	115/230	1.35	3.7/1.8	60	3450	-----	AUTO	N48 ODP

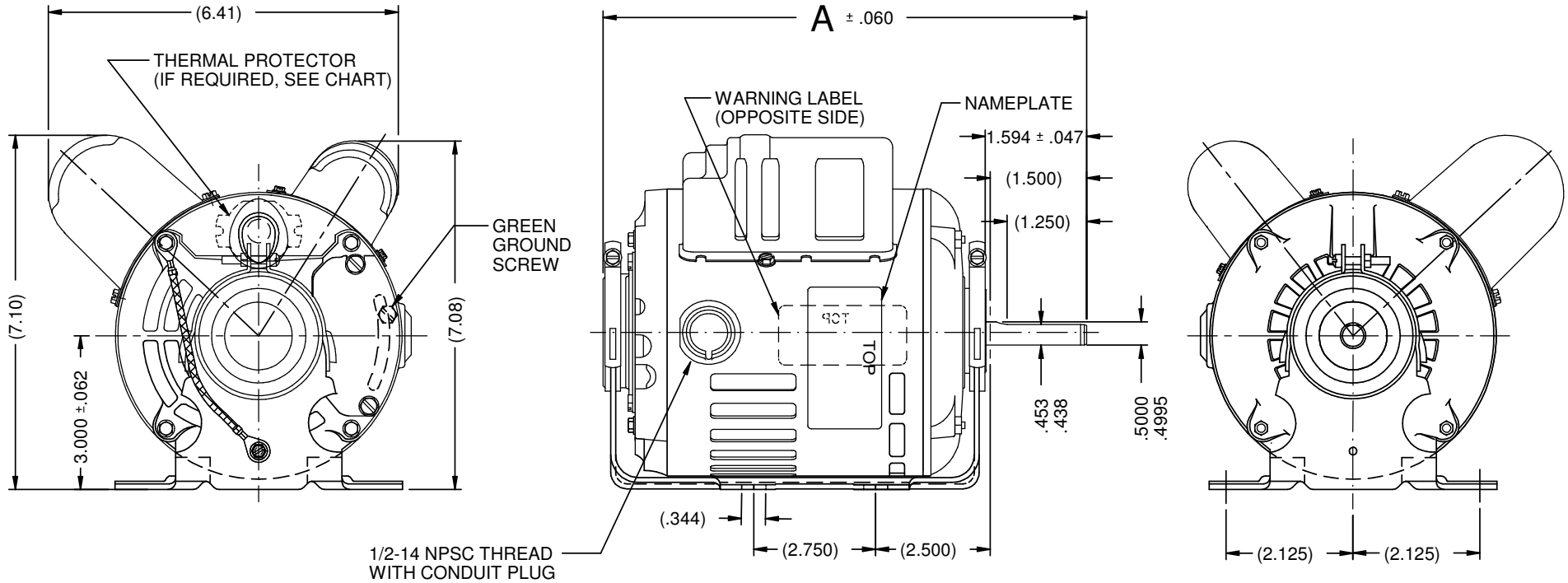

NIDEC MOTOR CORPORATION 07-Apr-15

MOTOR IS CCW LEAD END, TO REVERSE ROTATION INTERCHANGE RED AND BLACK LEADS

REFER TO S.E.I.M. 24-1

CREATED DRAWING		REVISION RECORD FOR:	JC 69681	TOLERANCES ON DIMENSIONS (UNLESS OTHERWISE SPECIFIED)				NIDEC MOTOR CORPORATION				INFORMATION DISCLOSED ON THIS DOCUMENT IS CONSIDERED PROPRIETARY AND SHALL NOT BE REPRODUCED OR DISCLOSED WITHOUT WRITTEN CONSENT OF NIDEC MOTOR CORPORATION		REVISION DATE:		11-MAY-15	
ISSUED BY:		ENGINEER APPROVED:		INCHES	mm	TITLE		CODE	ITEM NO.	REV	SHEET NUMBER	DWG SIZE					
N. MARTINEZ		T. BOSSALLER		.XX = ± .010		CUSTOMER DETAIL DRAWING		V02	804712	--	1 OF 4	B					
				ANGLES X° = ±1°													