

SHAFT KEY TAPED
TO MOTOR

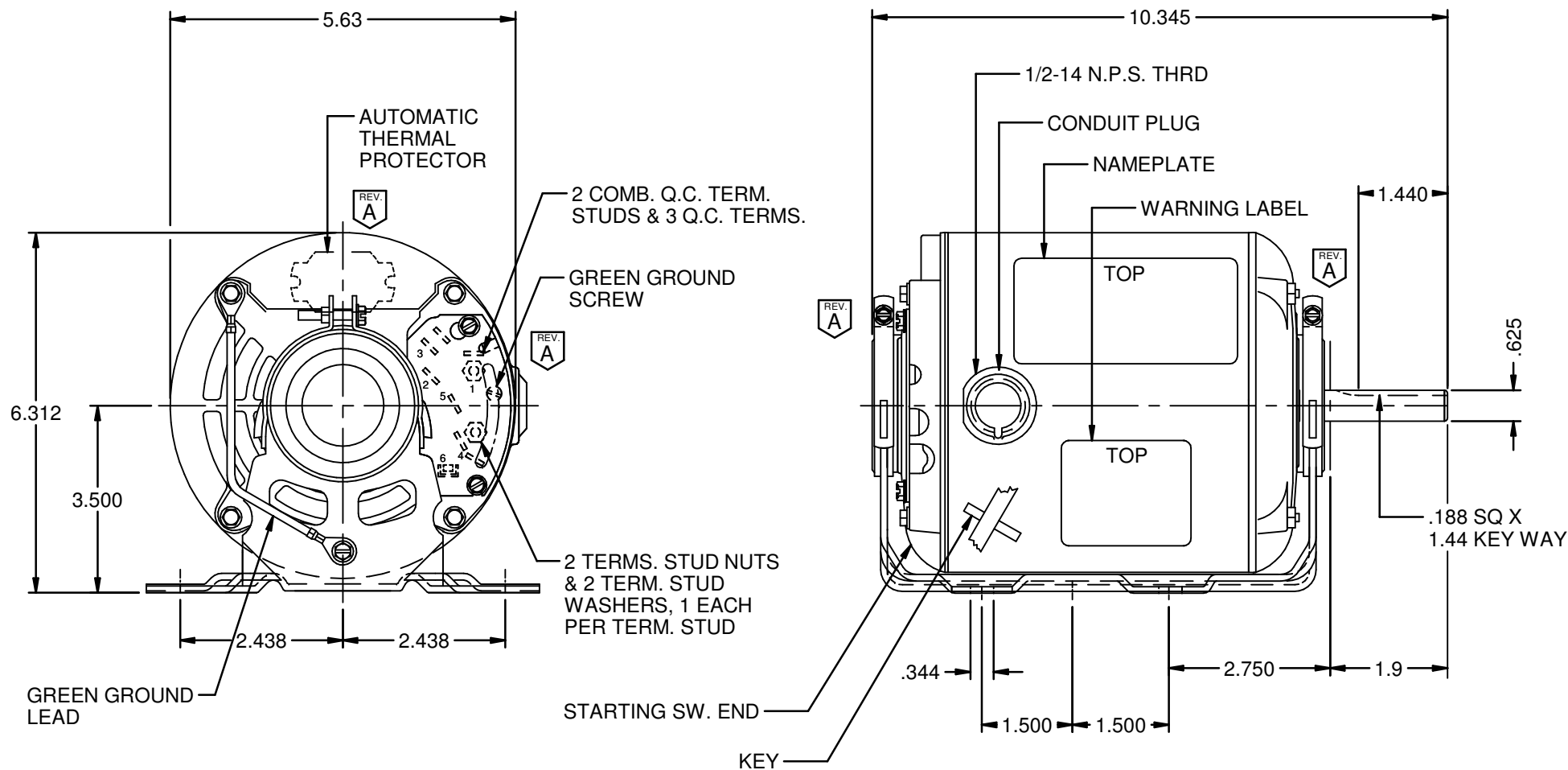

NIDEC MOTOR CORPORATION 20-Oct-14

MODEL	REF	CUSTOMER	HP	VOLTS	AMPS	HZ	RPM	ROTATION	CUSTOMER PN
S55JXGYU-8431		WHOLESALE HAC	1/2	115	8.0	60	1725	CCW LEAD END REV.	1369

SHEET NUMBER	REV	REVISION RECORD FOR: D2089-00	
1 OF 1	A	UPDATED VIEW SCRES TO S05249882	
		UPDATED VIEW TERMINAL COVER TO C74188412	
REVISION DATE	20-OCT-14		
ISSUED BY	I. DE LEON	REVIEWED BY	M. SCHUETTE
		ENGINEER APPROVED	M. GUZMAN

<p>INFORMATION DISCLOSED ON THIS DOCUMENT IS CONSIDERED PROPRIETARY AND SHALL NOT BE REPRODUCED OR DISCLOSED WITHOUT WRITTEN CONSENT OF NIDEC MOTOR CORPORATION</p> <p>ALL DIMENSIONS ARE FOR REFERENCE ONLY UNLESS TOLERANCE IS GIVEN</p>			
TITLE	ASSEMBLED VIEW	CODE	V01
ITEM NO.	802534	SIZE	A

NIDEC MOTOR CORPORATION	
--------------------------------	--