

SHAFT KEY TAPED TO MOTOR

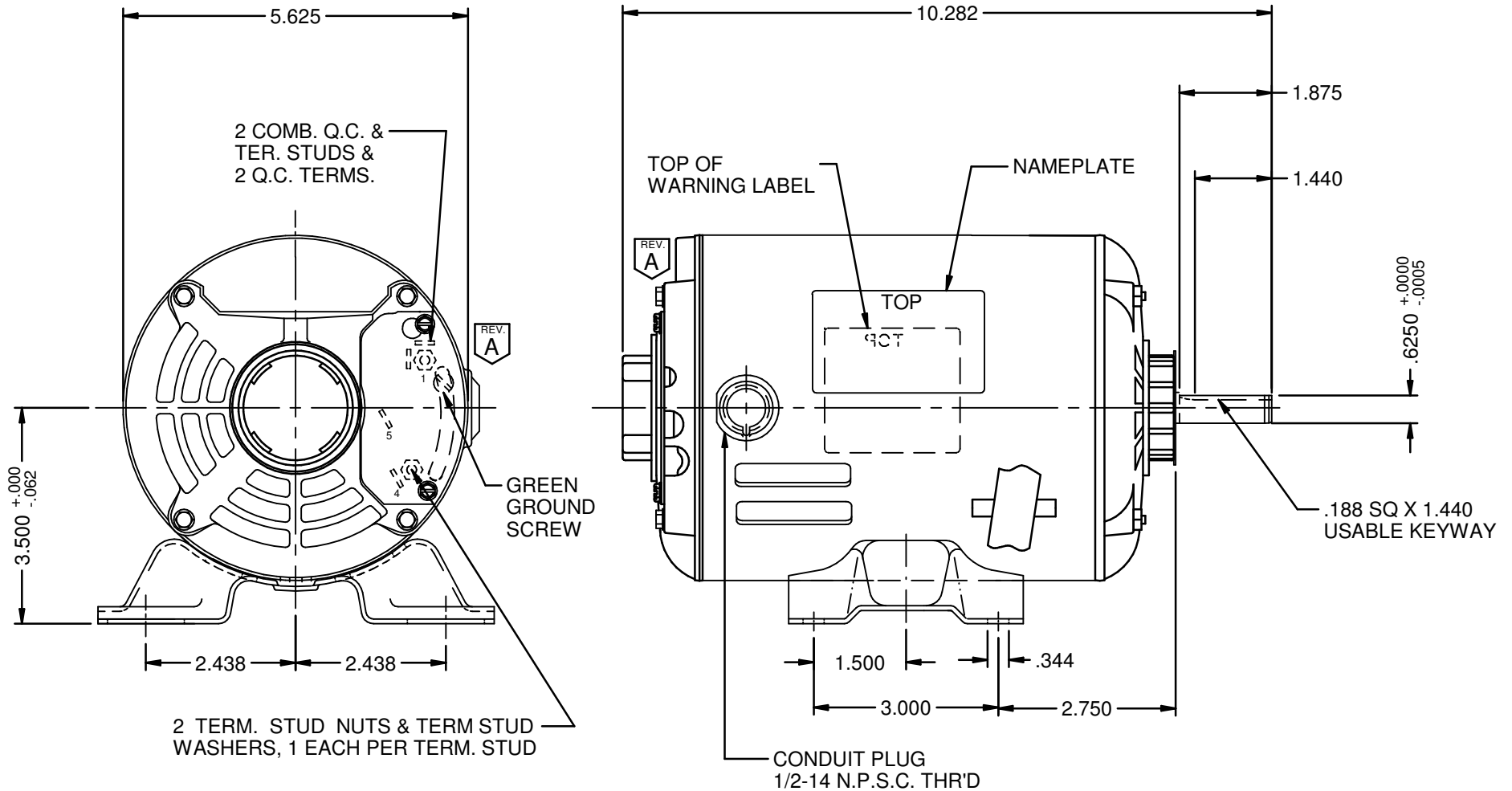

NIDEC MOTOR CORPORATION 21-Oct-14

MODEL	REF	CUSTOMER	HP	VOLTS	AMPS	HZ	RPM	ROTATION	CUSTOMER PN
S055GY-8434		WHOLESALE HAC	1/2	115	8.9	60	1725	CW/CCW	D12B2N

SHEET NUMBER	REV	REVISION RECORD FOR:	D2106-00
1 OF 1	A	CHANGED VIEW OF THE STATOR SCREW HEAD AND VIEW OF TERMINAL COVER.	
		CHANGED CUSTOMER PART FROM 1366 TO D12B2N	
REVISION DATE			
21-OCT-14			

INFORMATION DISCLOSED ON THIS DOCUMENT IS CONSIDERED PROPRIETARY AND SHALL NOT BE REPRODUCED OR DISCLOSED WITHOUT WRITTEN CONSENT OF NIDEC MOTOR CORPORATION

ALL DIMENSIONS ARE FOR REFERENCE ONLY UNLESS TOLERANCE IS GIVEN

<b>NIDEC MOTOR CORPORATION</b>		TITLE	CODE	ITEM NO.	SIZE
		ASSEMBLED VIEW	V01	802436	A

ISSUED BY	REVIEWED BY	ENGINEER APPROVED
I. GUTIERREZ	M. GUZMAN	M. GUZMAN