

#18, .031 THICK INSUL GREEN/YELLOW
GROUND LEAD TO BE 12.00 +1-1
BETWEEN CENTER OF TERMS., TERM
TO FIT #10 SCREW

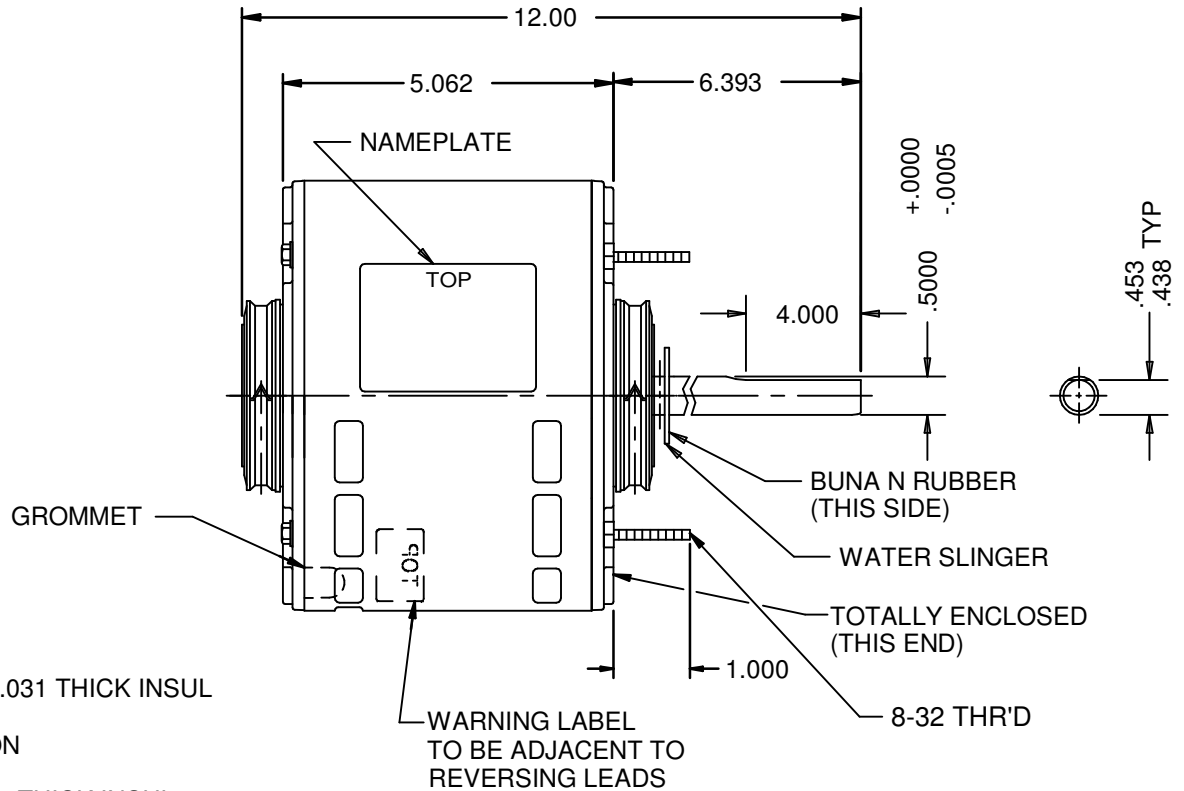
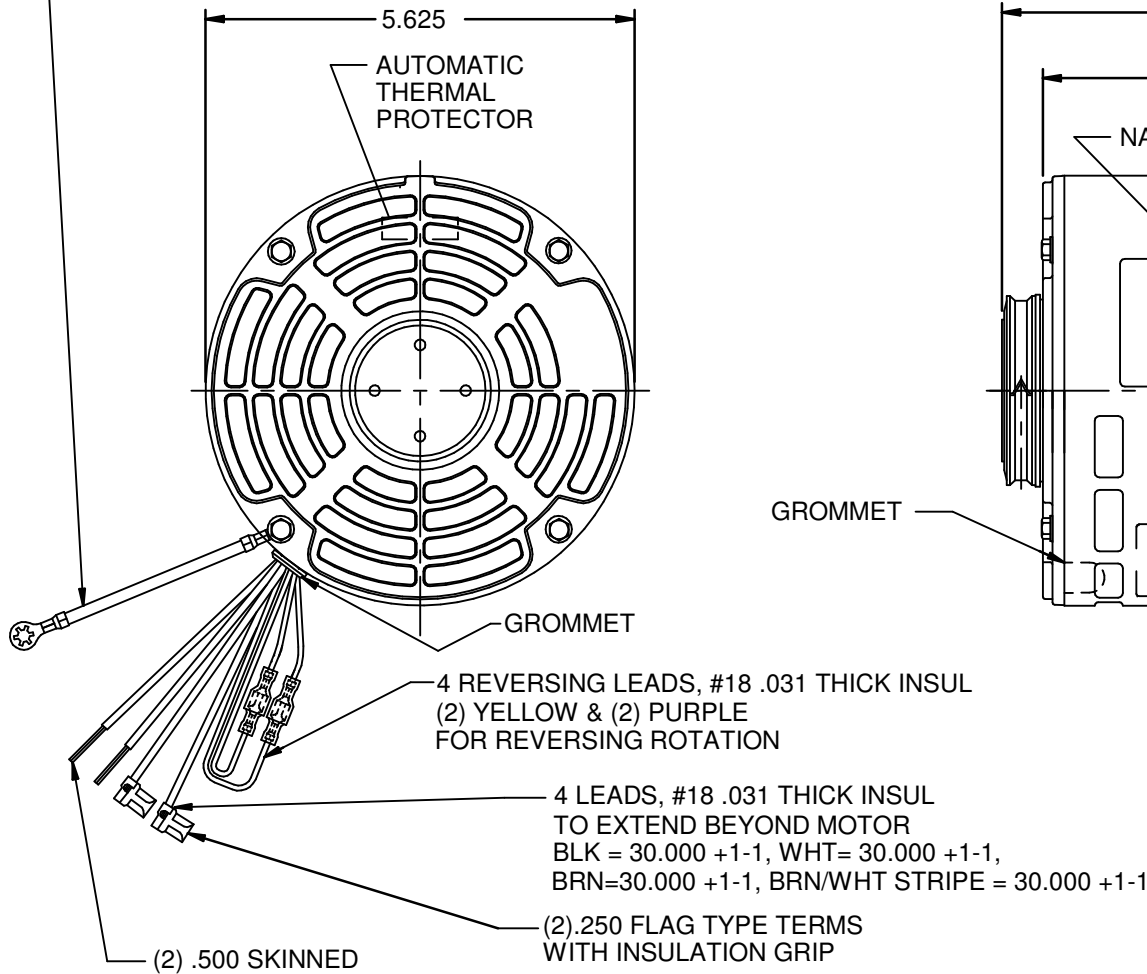

NIDEC MOTOR CORPORATION 16-Jul-14

MODEL	REF	CUSTOMER	HP	VOLTS	AMPS	HZ	RPM	ROTATION	CAT NO.	
K55HRAT-1811	C38505	WHOLESALE HAC	1/4	208-230	1.2	60	1625	CCW LEAD END REV	1355	
SHEET NUMBER 1 OF 1	REV --	REVISION RECORD FOR: JC 69068			INFORMATION DISCLOSED ON THIS DOCUMENT IS CONSIDERED PROPRIETARY AND SHALL NOT BE REPRODUCED OR DISCLOSED WITHOUT WRITTEN CONSENT OF NIDEC MOTOR CORPORATION				NIDEC MOTOR CORPORATION	
CREATED NEW DRAWING.										
REVISION DATE										
16-JUL-14					ALL DIMENSIONS ARE FOR REFERENCE ONLY UNLESS TOLERANCE IS GIVEN					
ISSUED BY E. VICENCIO	REVIEWED BY M. LARGENT	ENGINEER APPROVED M. LARGENT	TITLE ASSEMBLED VIEW				CODE V01	ITEM NO. 801990	SIZE A	