

AUTOMATIC THERMAL PROTECTOR
LACED TO WINDING

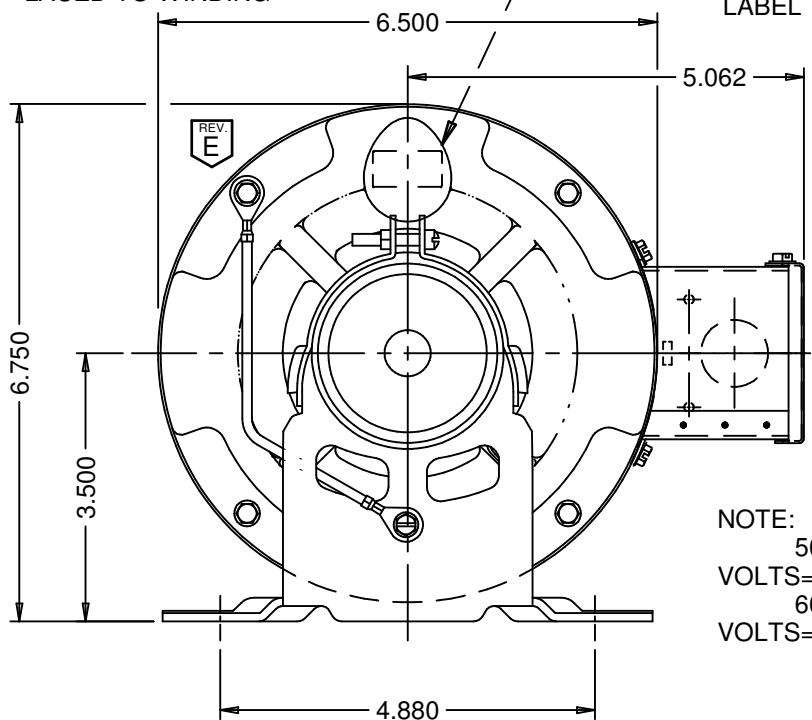

WIRE COLOR LABEL

GREEN GROUND SCREW

NOTE:
50 HZ
VOLTS=200-220/380-415
60 HZ
VOLTS=208-230/460

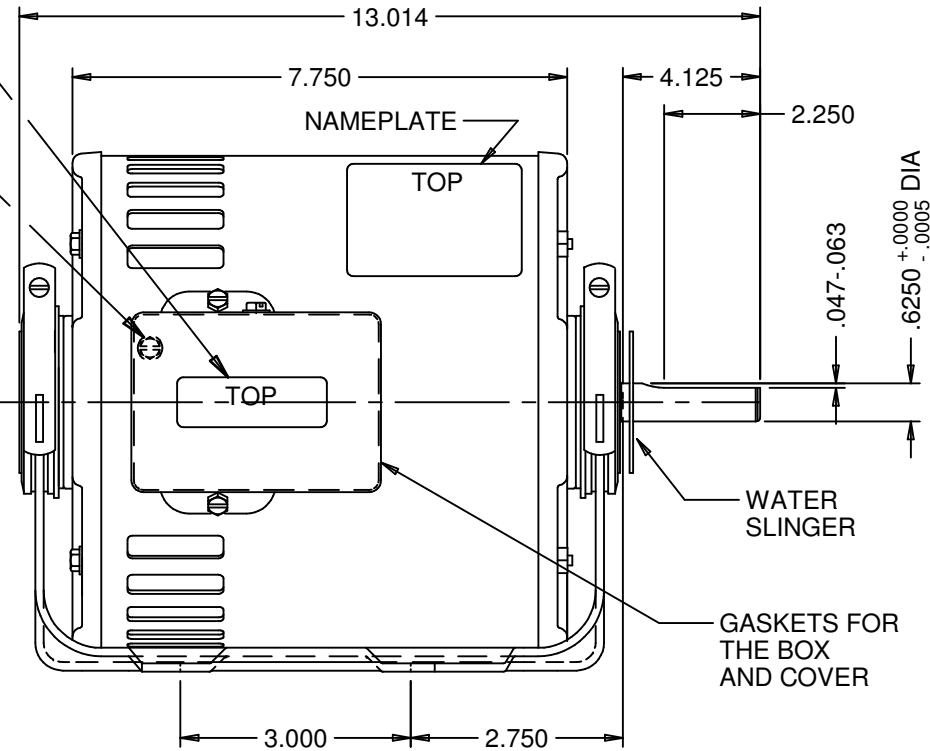

- NOTES:
1.) GROMMET IN SHELL WHERE LEADS EXIT MOTOR.
2.) BEARINGS REQUIRE KRYTOX GPL 225 GREASE WITH TEMP. RANGE OF -20°F TO 400°F.

6 LEADS #18 GA., .031 THICK INSULATION TO EXTEND BEYOND TOP OF OUTLET BOX. BUT BUNDLED INSIDE IT FOR SHIPMENT.
BROWN=8"±2", PUR=8"±2"
WHITE=8"±2", YELLOW=8"±2"
ORANGE=8"±2", RED=8"±2".
LEADS STRIPPED .750

CONNECTIONS

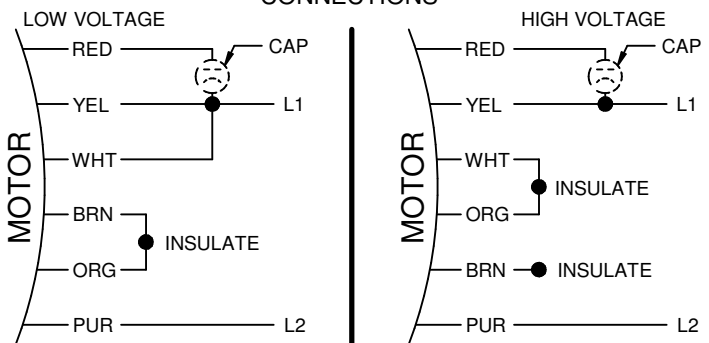

CAPACITOR IS SUPPLIED BY THE CUSTOMER.
FOR TEST, CONNECT CAPACITOR BETWEEN RED AND YEL LEADS

CAPACITOR ALWAYS BETWEEN RED AND YEL LEADS

NIDEC MOTOR CORPORATION 09-Oct-17

MODEL	REF	CUSTOMER	HP	VOLTS	AMPS	HZ	RPM	ROTATION	CUSTOMER PN
K63ZZSZD-4631		STANDARD	3/4	208-230/460	4.8/2.5	50/60	920/1100	CCW LEAD END	

CAT. NO.	CAPACITOR	PROTECTOR
3912	30 MFD / 440 V	7AM036

SHEET NUMBER	REV	REVISION RECORD FOR: ECO E29749
1 OF 1	E	CHANGED VIEW GROUND LEAD TO BEHIND BASE LE.
REVISION DATE		
10-OCT-17		

INFORMATION DISCLOSED ON THIS DOCUMENT IS CONSIDERED PROPRIETARY AND SHALL NOT BE REPRODUCED OR DISCLOSED WITHOUT WRITTEN CONSENT OF NIDEC MOTOR CORPORATION

NIDEC MOTOR CORPORATION

ALL DIMENSIONS ARE FOR REFERENCE ONLY UNLESS TOLERANCE IS GIVEN

ISSUED BY	REVIEWED BY	ENGINEER APPROVED
C. LUGO	F. FLORES	B. GAITAN

TITLE	CODE	ITEM NO.	SIZE
ASSEMBLED VIEW	V01	333346	A