



The SOS Switch is a solid state device designed to detect a clogged condition in condensate drain lines. It works by sensing when the water is near the top of the pipe that it is clamped onto and responds by opening the circuit to the compressor contactor.

Since there are no moving parts in the SOS switch, slime and sludge buildup do not affect operation until a blockage occurs. The SOS switch is triggered by a near full condition of the drain pipe and is not affected by condensation or water droplets inside of the pipe. Unlike other types of level or safety switches, the SOS does not require cutting or penetration into the pipe and does not interfere with normal fluid flow in any way.

The SOS switch is designed for use in a series connection between the thermostat cool (Y) terminal and the compressor contactor.

The yellow light on the SOS switch is triggered by water near the top of the pipe (center sensor plate). When the SOS has been triggered, the yellow light remains on and the compressor will remain off until the high water condition is corrected and the power or thermostat is cycled off then on.

*** For use with 24 VAC control circuits.**

*** Always test the system after installation of any new control to ensure compatibility.**

Cross-Section View

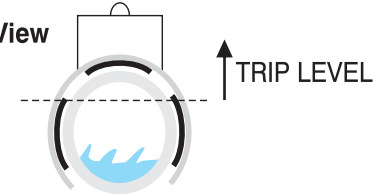

NOTE: Pipe must be 80% or more full at the SOS location for a tripped condition to occur

SPECIFICATIONS:

APPLICATION:

3/4 inch SCH 40 or PSI-200 PVC Drain Lines.
Test if applying to other types of plastic drain pipes.

INDICATORS:

Yellow LED indicates moisture detected

POWER REQUIREMENTS:

Operates in series with 24 VAC contactor load.

CURRENT CAPACITY:

Can operate contactor coils requiring up to 1.25 Amps

LATCHING OPERATION RESET:

Remove power
Remove pipe obstruction
Re-apply power

Installation:

Connect the SOS Switch in series with the compressor control contactor as shown. **WIRE THIS DEVICE INTO THE “Y” CIRCUIT ONLY (AS NOTED IN CONNECTION DIAGRAM). WIRING IT INTO THE RED CIRCUIT OR ANY OTHER CIRCUIT COULD RESULT IN PRODUCT OR SYSTEM MALFUNCTION.**

1. Power system off.
2. Cut one wire going to the compressor contactor.
3. Connect SOS Switch wires to the cut ends and install wire nuts.
4. With SOS switch away from tubing, turn system on.
5. Compressor should operate normally.
6. Test switch by pressing the Push To Test button. Compressor will shut off and yellow light on SOS Switch will illuminate.
7. Snap the SOS switch on a convenient location on the PVC condensate drain line (or install the included pipe adapter into the secondary overflow drain hole) and snap the SOS switch onto the adapter.
8. If desired, secure the position of the SOS switch with a nylon wire tie around pipe and SOS switch. PVC cement may also be used but must be dry before test operation.
9. Cycle system power or thermostat off for 5 seconds to reset SOS Switch.

TYPICAL CONNECTION

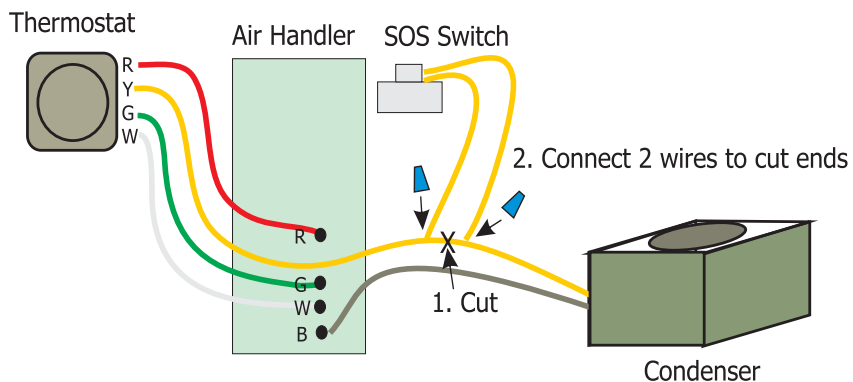

DIVERSITECH CORP.
AUTOMATIC WATER SENSOR
24 VAC 1.25 AMP CLASS 2 WIRING
PLASTIC DRAIN LINES ONLY

POSITION SWITCH BODY
AWAY FROM NORMAL FLOW
patents pending

