

**WIRELESS CONTROL RELAYS WITH TWO-WAY COMMUNICATION**

**RIBW01B-EN3**

Enclosed EnOcean® Enabled Wireless Relay Transceiver / Repeater 20 Amp SPDT, 120 Vac Power, with Dry Contact Input

**RIBW208B-EN3**

Enclosed EnOcean® Enabled Wireless Relay Transceiver / Repeater 20 Amp SPDT, 208 Vac Power, with Dry Contact Input

**RIBW240B-EN3**

Enclosed EnOcean® Enabled Wireless Relay Transceiver / Repeater 20 Amp SPDT, 240 Vac Power, with Dry Contact Input

**RIBW277B-EN3**

Enclosed EnOcean® Enabled Wireless Relay Transceiver / Repeater 20 Amp SPDT, 277 Vac Power, with Dry Contact Input

**RIBW24B-EN3**

Enclosed EnOcean® Enabled Wireless Relay Transceiver / Repeater 20 Amp SPDT, 24 Vac/dc Power, with Dry Contact Input

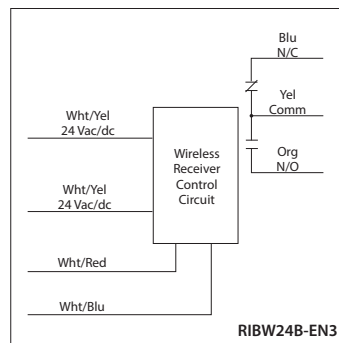
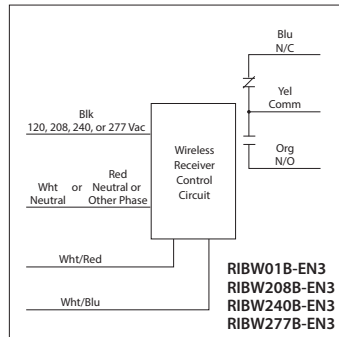

enocean alliance

**RELAY HAS BUILT-IN REPEATER FUNCTION. RELAY RECEIVES SIGNAL FROM WIRELESS SWITCH TRANSMITTER AND REBROADCASTS THE SIGNAL TO THE NEXT RELAY RECEIVER.**

**SPECIFICATIONS**

- # Relays & Contact Type: One (1) SPDT Continuous Duty Coil
- Expected Relay Life: 10 million cycles minimum mechanical
- Operating Temperature: -30 to 140° F
- Humidity Range: 5 to 95% (noncondensing)
- Red LED: Relay Status / Learn Mode Status (Flashing)
- Dimensions: 2.30" x 3.20" x 1.80" with .50" NPT Nipple
- Wires: 16", 600V Rated
- Approvals: UL Listed, UL916, C-UL, RoHS,
- Agency Compliance: FCCID: SZV-TCM3200  
IC: 5713A-TCM3200
- Housing Rating: UL Accepted for Use in Plenum, NEMA 1
- Gold Flash: No
- Override Switch: No
- Frequency: 902 MHz
- Receiver Sensitivity: -93 dBm typical
- Conducted Power: 5 mW typical
- Built-in Switch Modes: Alarm, Repeater, Delay, Rocker, Momentary, and Toggle

- Contact Ratings:**
- 20 Amp Resistive @ 277 Vac
- 20 Amp Ballast @ 277 Vac
- 16 Amp Electronic Ballast @ 277 Vac (N/O)
- 10 Amp Tungsten @ 120 Vac (N/O)
- 770 VA Pilot Duty @ 120 Vac
- 1,110 VA Pilot Duty @ 277 Vac
- 2 HP @ 277 Vac
- 1 HP @ 120 Vac
- Power Input Ratings:**
- 73 mA @ 120 Vac ; 60 Hz (RIBW01B-EN3)
- 80 mA @ 208 Vac ; 60 Hz (RIBW208B-EN3)
- 80 mA @ 240 Vac ; 60 Hz (RIBW240B-EN3)
- 80 mA @ 277 Vac ; 60 Hz (RIBW277B-EN3)
- 139 mA @ 24 Vac (RIBW24B-EN3)
- 69 mA @ 24 Vdc (RIBW24B-EN3)

- Notes:**
- Compatible with EnOcean® 902 MHz Switches/Transmitters.
- Typical range: 50-150 ft.
- Open area transmission could be farther. Consult factory for more information.
- Repeater function only rebroadcasts original EnOcean® transmission. Up to two repeaters can be used.
- Version 1.5 firmware or later implements Functional Devices, Inc.'s EnOcean® Manufacturer ID of 0x055.
- For setup instructions, see website for -EN3 Series Application Manual: [www.functionaldevices.com/pdf/bulletins/B1867\\_393231.pdf](http://www.functionaldevices.com/pdf/bulletins/B1867_393231.pdf) or scan QR code with your smart phone.



**APPLICATION FOR WIRELESS CONTROL & FEEDBACK IN A BUILDING AUTOMATION SYSTEM**

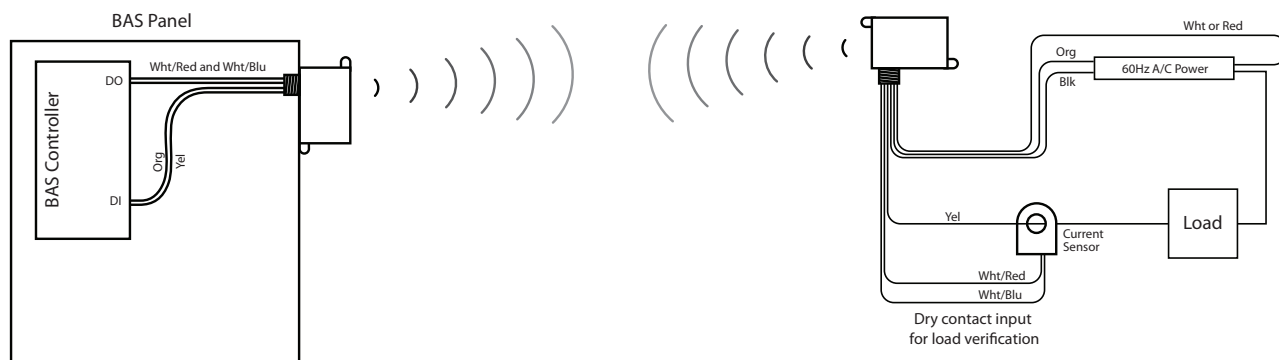

WIRELESS DEVICES