

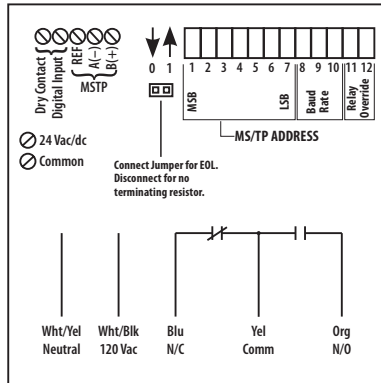

**Open Protocol Relay**

**RIBTW2401B-BC**

Enclosed BACnet® MS/TP Network Relay Device; One Discrete Output (20 Amp Relay SPDT); One Discrete Input; 24 Vac/dc or 120 Vac Power, **End of Line Resistor (EOL) included**



**RIBTW2402B-BC**

Enclosed BACnet® MS/TP Network Relay Device; One Discrete Output (20 Amp Relay SPDT); One Discrete Input; 24 Vac/dc or 208-277 Vac Power, **End of Line Resistor (EOL) included**

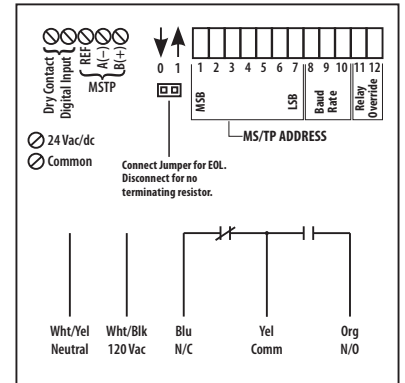

**SPECIFICATIONS**

- # Relays & Contact Type: One (1) SPDT Continuous Duty Coil
- Expected Relay Life: 10 million cycles minimum mechanical
- Operating Temperature: -30 to 140° F
- Operate Time: 18ms
- Green LED: Network Communication
- Red LED: Relay Status
- Dimensions: 4.00" x 4.00" x 1.80" with .50" NPT Nipple
- Wires: 16", 600V Rated
- Approvals: CE, UL Listed, UL916, C-UL, RoHS
- Housing Rating: Plenum, NEMA 1
- Gold Flash: No
- Relay Override Switch: Coil Side (DIP Switches 11 & 12)
- Network Media: Twisted Pair 22-24AWG, shielded recommended
- Terminations: Functional Devices product installed at both ends of the MS/TP network – Use 120 Ωend of line resistors. All other cases – Follow instructions from the device installed at the end of the MS/TP network.
- Polarity: Network is polarity sensitive
- Band Rate: 9600, 19200, 38400, 57600, 76800, 115200 (Dip Switch Selectable)

**Contact Ratings:**

- 20 Amp Resistive @ 277 Vac
- 20 Amp Ballast N/O @ 120/277 Vac
- 10 Amp Ballast N/C @ 277 Vac
- 10 Amp Tungsten N/O @ 120 Vac
- 1110 VA Pilot Duty @ 277 Vac
- 770 VA Pilot Duty @ 120 Vac
- 2 HP @ 277 Vac
- 1 HP @ 120 Vac

**Power Input Ratings:**

- 81 mA @ 24 Vdc
- 111 mA @ 24 Vac
- 96 mA @ 120 Vac (RIBTW2401B-BC)
- 121 mA @ 208-277 Vac (RIBTW2402B-BC)

**Power Input:**

- 24 Vac/dc ; 120 Vac ; 50-60 Hz (RIBTW2401B-BC)
- 24 Vac/dc ; 208-277 Vac ; 50-60 Hz (RIBTW2402B-BC)

**Notes:**

- » MS/TP Address & Baud Rate must be set prior to power up via DIP switches.
- » Device ID will default to 277XXX where XXX is the MS/TP Address.
- Examples:
 

MS/TP Address - 004
Device ID - 277004

MS/TP Address - 121
Device ID - 277121
- » Device ID can be changed via network command. Once changed, it will no longer default to 277XXX. (MS/TP Address & Device ID must be unique.)
- » PIC Statement Available for Download
- » Objects included in device are:
  - BO 1 (Binary output)
  - BI 1 (Binary input)
  - BI 2 (Binary input)
  - AI 1 (Analog input)
- » This model utilizes only:
  - BO 1 - Relay output
  - BI 1 - Dry contact digital input
- » Device Instance changed via Object Identifier Property of Device Object
- » Each unit is 1/8 unit load if date code 041510 or later. (One full load prior to 041510)

DIP Switches			Baud Rate
8	9	10	
0	0	0	9600
0	0	1	19200
0	1	0	38400
0	1	1	57600
1	0	0	76800
1	0	1	115200

DIP Switches		Relay State*
11	12	
1	0	Auto
X	1	Override on
0	0	Override off

\*Device must be powered for override

All other combinations=9600 baud

» Dry contact digital input is a general purpose input that is not tied to the relay internally. Can be used with any dry contact switching device, such as a current sensor, to feed back to the network.