

**NETWORK COMPATIBLE RELAY**

**RIBMW24B-44-BC**

4.00" Track Mount BACnet® MS/TP Network Relay Device; Four Binary Outputs (20 Amp Relay SPDT + Override); Four Binary Inputs (Dry Contact Binary Inputs), 24 Vac/dc Power Input, Optional End of Line Resistor (EOL) Included.

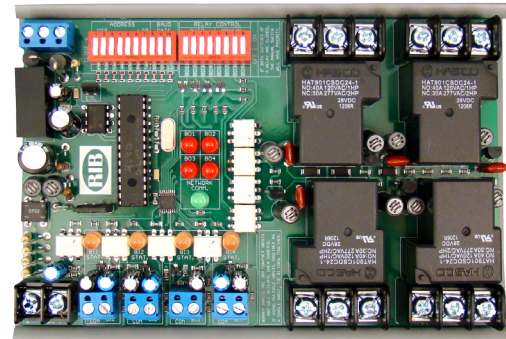
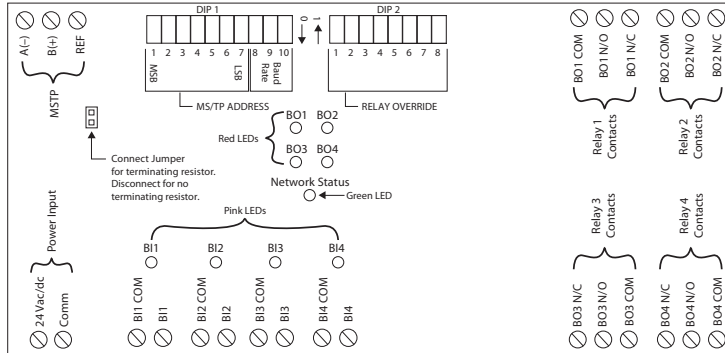

**SPECIFICATIONS**

- # Relays & Contact Type:** Four (4) SPDT Continuous Duty Coil
- Expected Relay Life:** 10 million cycles minimum mechanical
- Operating Temperature:** -30 to 140° F
- Humidity Range:** 5 to 95% (noncondensing)
- Operate Time:** 18ms
- Network Communication:** Green LED
- Relay Status:** Red LED On = Activated
- Binary Input Status:** Pink LED On = Activated
- Dimensions:** 6.00" L x 4.27" W x 1.34" H
- Track Mount:** MT4-6 Mounting Track Provided
- Approvals:** CE, UL Listed, UL916, C-UL, RoHS
- Gold Flash:** No
- Relay Override Switch:** DIP Switch Control

- Network Media:** Twisted Pair 22-24AWG, shielded recommended
- Terminations:** Functional Devices product installed at both ends of the MS/TP network – Use 120 Ω end of line resistors. All other cases – Follow instructions from the device installed at the end of the MS/TP network.
- Polarity:** Network is polarity sensitive
- Baud Rate:** 9600, 19200, 38400, 57600, 76800, 115200 (Dip Switch Selectable)

- Contact Ratings:**
  - 20 Amp Resistive @ 277 Vac
  - 20 Amp Ballast @ 120/277 Vac
  - 16 Amp Electronic Ballast @ 277 Vac (N/O)
  - 10 Amp Tungsten @ 120 Vac (N/O)
  - 1110 VA Pilot Duty @ 277 Vac
  - 770 VA Pilot Duty @ 120 Vac
  - 2 HP @ 277 Vac
  - 1 HP @ 120 Vac
- Power Input Ratings:**
  - 24 Vac : 400 mA
  - 24 Vdc : 190 mA

- BACnet® Details:**
  - MS/TP Address & Baud Rate must be set prior to power up via DIP switches.
  - Device ID will default to 277XXX where XXX is the MS/TP Address.
  - Examples:
    - MS/TP Address - 004  
Device ID - 277004
    - MS/TP Address - 121  
Device ID - 277121
  - Device ID can be changed via network command. Once changed, it will no longer default to 277XXX. (MS/TP Address & Device ID must be unique)
  - This model utilizes: BO1, BO2, BO3, BO4, (Relay outputs), BI1, BI2, BI3, BI4 (Dry contact inputs)
  - Device Instance changed via Object Identifier Property of Device Object
  - Each unit is 1/8 unit load
  - PIC Statement available on website.
  - [http://www.functionaldevices.com/pdf/pics/RIBMW24B-44-BC\\_PICS.pdf](http://www.functionaldevices.com/pdf/pics/RIBMW24B-44-BC_PICS.pdf)
  - Or scan QR code with your smart phone.

**NEED AN ENCLOSURE?**  
ORDER MODEL MH1210 (PAGE 142)

**NEED A POWER SUPPLY AND AN ENCLOSURE?**  
ORDER MODEL CTRL-PS (PAGE 113) & AT4-8 (PAGE 152)



DIP 1		DIP Switches		Baud Rate	
		1-7	8	9	10
See Bulletin B1082 for full MS/TP Addressing	0	0	0	0	9600
	0	0	0	1	19200
	0	0	1	0	38400
	0	1	1	0	57600
	1	0	0	0	76800
	1	0	1	115200	

All other combinations=9600 baud

• Dry contact digital input is a general purpose input that is not tied to the relay internally. Can be used with any dry contact switching device, such as a current sensor, to report back to the network.

		DIP 2							
Relay	Relay State**	DIP Switches*							
		1	2	3	4	5	6	7	8
BO1	Auto	1	X	X	X	0	X	X	X
	ON	X	X	X	X	1	X	X	X
	OFF	0	X	X	X	0	X	X	X
BO2	Auto	X	1	X	X	X	0	X	X
	ON	X	X	X	X	X	1	X	X
	OFF	X	0	X	X	X	0	X	X
BO3	Auto	X	X	1	X	X	X	0	X
	ON	X	X	X	X	X	X	1	X
	OFF	X	X	0	X	X	X	0	X
BO4	Auto	X	X	X	1	X	X	X	0
	ON	X	X	X	X	X	X	X	1
	OFF	X	X	X	0	X	X	X	0

\* 0 = Open ; 1 = Closed      \*\* Device must be powered for override