



This manual covers the following models:

- **R250S** (Requires a Wired Sensor Capable Thermostat)

**Congratulations on purchasing a PRO1 Wired Sensor.**

This remote sensor was designed to the highest reliability and ease of use standards. Thank you for choosing Pro1.



**Caution:**

**Equipment damage hazard**

Do not operate the cooling system if the outdoor temperature is below 50° F (10° C) to prevent possible compressor damage.

Table of Contents	Page
New Installations	2, 3
Wiring	3
Connecting to a Thermostat	4
Resistance Chart	5
Contact Us and Warranty Registration	6

**Need Help?**

For assistance with this product please visit <http://www.pro1iaq.com> or call Pro1 Customer Care toll-free at 888-Pro1iaq (776-1427) during normal business hours (Mon-Fri 9 AM - 6 PM Eastern)

Una versión española de este manual puede ser descargada en [www.pro1iaq.com](http://www.pro1iaq.com)

### Installing the R250S as a Floor Sensor

Before wiring, the R250S needs to be installed. The stainless steel housing allows this sensor to be placed into concrete, thin-set, and grout. The following five examples demonstrate the proper way to install a R250S as a floor sensor in conventional floor construction.

#### Thick Covering - Greater Than 3/8" (10mm)

If the thick floor covering is installed directly to the subfloor, a 1/8" (4mm) wide by 1/16" (2mm) deep groove should be cut into the **back of the floor cover** to allow for the R250S wire. Position the sensor in such a place that the wire can reach the location of its junction box. The groove for where the sensor will be placed should be 1/4" (8mm) wide by 1/4" (8mm) deep by 1 3/4" (45mm) long. For accurate temperature reading, the sensor should be located exactly between heating elements.

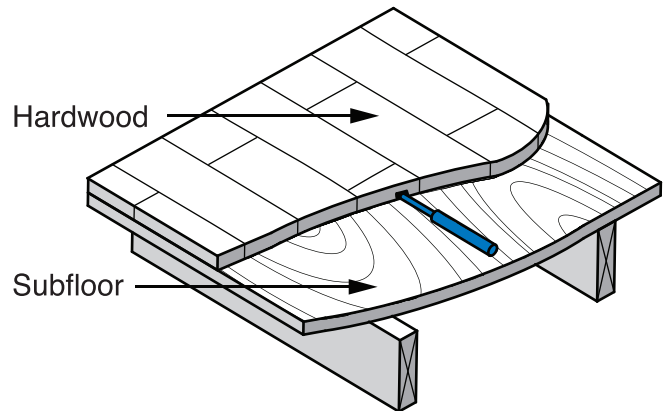

#### Thin Covering - Less Than 3/8" (10mm)

If the thin floor covering is installed directly to the subfloor, a 1/8" (4mm) wide by 1/16" (2mm) deep groove should be cut into the **surface of the subfloor** to allow for the R250S wire. Position the sensor in such a place that the wire can reach the location of its junction box. The groove for where the sensor will be placed should be 1/4" (8mm) deep by 1 3/4" (45mm) long. For accurate temperature reading the sensor should be located exactly between the heating elements.

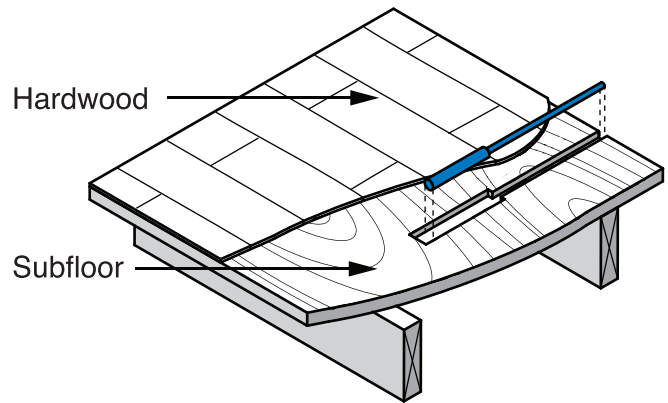

#### Thin-Set or Thin-Pour

If the floor covering is installed over the thin-set or thin-pour material of sufficient depth, the R250S sensor can be placed into **either material** and then covered by the floor covering. Position the sensor in such a place that the wire can reach the location of its junction box. For accurate temperature reading, the sensor should be located exactly between the heating elements.

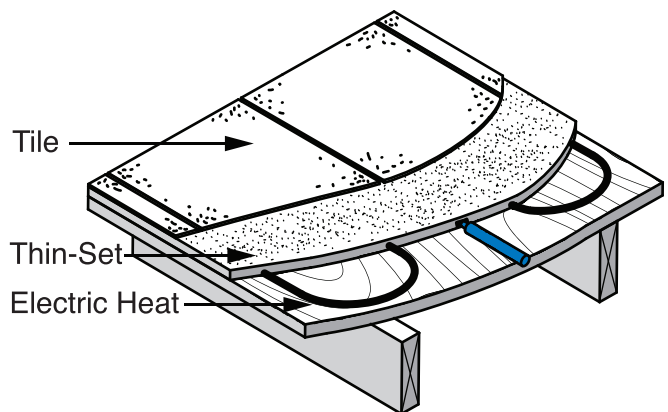

### Installing to the bottom of the subfloor

If installing the R250S sensor to the **bottom of the subfloor**, cut a piece of 1" (25mm) thick insulation into a 6" (150mm) by 6" (150mm) square. A 1/4" (8mm) wide by 1/4" (8mm) deep by 1 3/4" (45mm) long groove should be cut into the insulation to allow for the sensor. Position the sensor in such a place that the wire can reach the location of its junction box. Use a preferred and effective method to fasten the insulation to the subfloor.

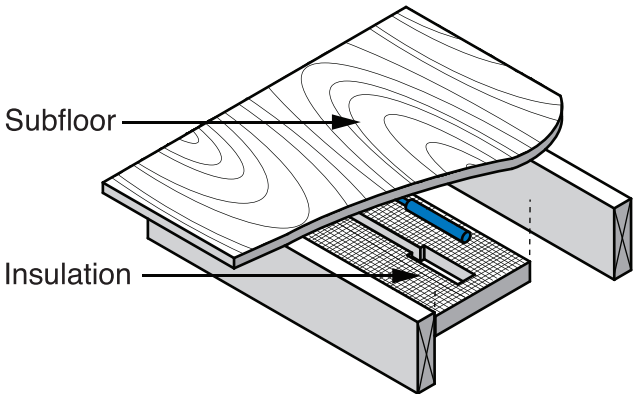

### Tile Flooring

The R250S sensor can be installed into **existing tile with adequate grout lines**. Select a location for the sensor that is exactly between the heating elements and in a low traffic area. Position the sensor in such a place that the wire can reach the location of its junction box. Remove enough of the grout line to place the sensor and wire in the floor. Then re-fill the area.

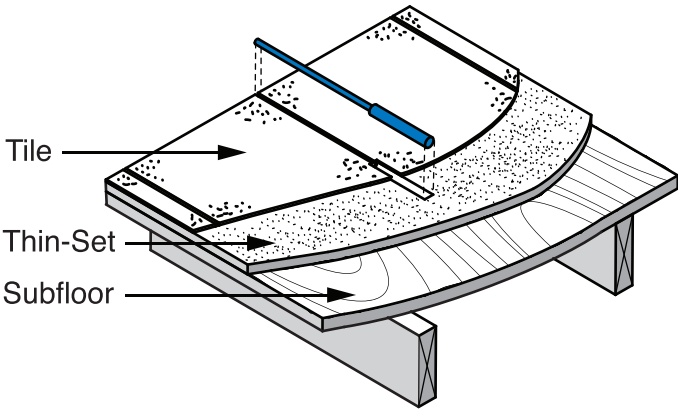

### Installing the R250S as an Outdoor Sensor

The R250S can also be used as an Outdoor Temperature Sensor. Included in the package is a metal wall mount and 2 screws. Securely screw the mount with the R250S into a shaded area.

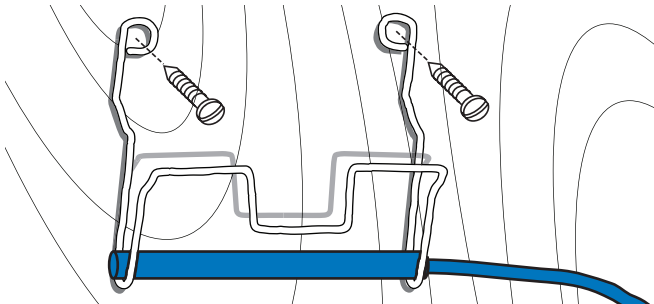

### Wiring the R250S

The R250S is packaged with 6' of 1.8mm cable. If you need more length, 24 AWG or larger wire can be joined onto the two wires from the sensor. The splices need to be properly joined and protected in an accessible junction box.



#### Warning:

**Do NOT** run the wires parallel to telephone or power cables. If there is a strong source of electromagnetic interference near the location of the sensor wires, a twisted pair or a protected cable should be used. The wires can also be run in a grounded metal conduit.

### Connecting to a Wired Sensor Capable Thermostat

After installation connect the R250S to the S terminal blocks on the Wired Sensor Capable Thermostat. Loosen the terminal block screws. Insert wires, then retighten terminal block screws.

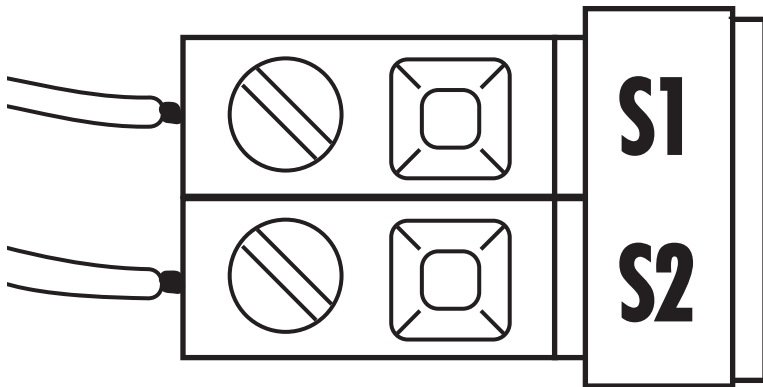

R250S Remote Sensor



**NOTE:** Refer to your Wired Sensor Capable Thermostat manual for setup.

### Specifications

#### R250S Wired Sensor

Temperature range ..... -4°F to 140°F (-20°C to 60°C)  
Temperature accuracy ..... ± 1°F  
Transmission ..... Constant Resistance

### 100K Thermistor Output Table

°F	°C	Ohms	°F	°C	Ohms	°F	°C	Ohms
-39	-39.44	3916295	37	2.78	302466	113	45.00	41303
-37	-38.33	3627711	39	3.89	285206	115	46.11	39434
-35	-37.22	3362274	41	5.00	269035	117	47.22	37660
-33	-36.11	3117987	43	6.11	253877	119	48.33	35976
-31	-35.00	2893035	45	7.22	239664	121	49.44	34376
-29	-33.89	2685770	47	8.33	226331	123	50.56	32843
-27	-32.78	2494694	49	9.44	213819	125	51.67	31399
-25	-31.67	2318444	51	10.56	201971	127	52.78	30027
-23	-30.56	2155781	53	11.67	190946	129	53.89	28722
-21	-29.44	2004274	55	12.78	180588	131	55.00	27481
-19	-28.33	1865595	57	13.89	170853	133	56.11	26300
-17	-27.22	1737397	59	15.00	161700	135	57.22	25177
-15	-26.11	1618827	61	16.11	153092	137	58.33	24107
-13	-25.00	1509102	63	17.22	144992	139	59.44	23089
-11	-23.89	1407512	65	18.33	137367	141	60.56	22111
-9	-22.78	1313405	67	19.44	130189	143	61.67	21188
-7	-21.67	1226184	69	20.56	123368	145	62.78	20308
-5	-20.56	1145306	71	21.67	117000	147	63.89	19469
-3	-19.44	1069620	73	22.78	110998	149	65.00	18670
-1	-18.33	1000019	75	23.89	105338	151	66.11	17907
1	-17.22	935383	77	25.00	100000	153	67.22	17180
3	-16.11	875329	79	26.11	94963	155	68.33	16486
5	-15.00	819505	81	27.22	90208	157	69.44	15824
7	-13.89	767589	83	28.33	85719	159	70.56	15187
9	-12.78	719284	85	29.44	81479	161	71.67	14584
11	-11.67	674319	87	30.56	77438	163	72.78	14008
13	-10.56	632442	89	31.67	73654	165	73.89	13458
15	-9.44	593086	91	32.78	70076	167	75.00	12932
17	-8.33	556739	93	33.89	66692	169	76.11	12430
19	-7.22	522842	95	35.00	63491	171	77.22	11949
21	-6.11	491217	97	36.11	60461	173	78.33	11490
23	-5.00	461699	99	37.22	57594	175	79.44	11051
25	-3.89	434134	101	38.33	54878	177	80.56	10627
27	-2.78	408383	103	39.44	52306	179	81.67	10225
29	-1.67	384316	105	40.56	49847	181	82.78	9841
31	-0.56	361813	107	41.67	47538	183	83.89	9473
33	0.56	340581	109	42.78	45349	185	85.00	9121
35	1.67	320895	111	43.89	43273	187	86.11	8783

## Contact Us Information

---

### Pro1 IAQ Inc.

1111 S. Glenstone  
Suite 2-100  
Springfield, MO 65804

**Toll-free:** 1-888-Pro1iaq (776-1427)

**Toll Number (Outside the USA):** 330-821-3600

**Web:** <http://www.pro1iaq.com>

**Hours of Operation:** Monday - Friday 9 AM - 6 PM Eastern

### Warranty Registration:

Your new Pro1 wired sensor has a 5 year limited warranty. You must register your warranty within 60 days of installation. You can register your new sensor in 2 ways.

① Go to [www.pro1iaq.com](http://www.pro1iaq.com), select warranty registration and fill out a short registration form.

- or -

② Complete the form below and mail it to the address shown.

---



### Pro1 IAQ Warranty Registration:

Name: \_\_\_\_\_

Address: \_\_\_\_\_

City: \_\_\_\_\_

State: \_\_\_\_\_

Zip: \_\_\_\_\_

Thermostat Model: \_\_\_\_\_

Date Installed: \_\_\_\_\_

**Complete form and mail to:**

### Pro1 IAQ Inc.

1111 S. Glenstone  
Suite 2-100  
Springfield, MO 65804