

**UNINTERRUPTIBLE POWER SUPPLY KIT**

**PSH600-UPS**

Kit Consisting of Enclosed Power Control Center Model PSH2RB10 (10 Amp Switch / Circuit Breaker, Two (2) 120 Vac Outlets, Terminals, 120 Vac Input) with a 600 VA UPS. (No Status Contacts)

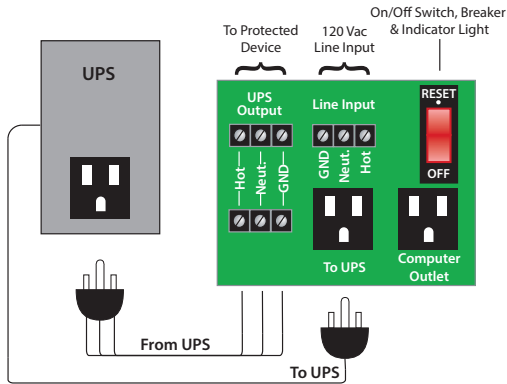

**SPECIFICATIONS**

**UPS**

- UPS:** 600VA
- Backup Time:** 2.5 Min. @ Full 600 VA Load  
10.2 Min. @ 1/2 Load
- Input:** 120 Vac, 12 Amp
- Output:** 120 Vac, 4.6 Amp
- Max Load:** 330 Watt
- Frequency:** 50/60 Hz
- Temperature Rating of UPS:** 32 to 104° F
- UPS Transfer Time:** 6ms
- Approvals:** UL Listed, UL1778
- Weight:** 8.4 lbs.

**PSH2RB10**

- Operating Temperature:** -30 to 140° F
- Humidity Range:** 5 to 95% (noncondensing)
- Main Breaker ON/OFF:** Switch / Breaker (10 Amp)
- Approvals:** UL Listed, UL916, C-UL, CE, RoHS
- Dimensions:** 12.000" x 14.000" x 6.000"  
Metal Housing with Screw Cover

**Shipping Weight:**  
22.3 lbs.

**Product Weight:**  
17.3 lbs.

- Notes:**
- To order without UPS, so that any other commercial UPS with appropriate ratings and within housing space limitations may be used, see model PSH2RB10.
  - To order interface board for replacement or for separate use, order model PSM2RB10.
  - **Average battery life: 3-5 years depending on the number of discharge cycles and environmental temperature**

**ESTIMATED BACKUP TIME VS. LOAD**

