



Shown Without Cover



Shown With Cover



## Uninterruptible Power Supply in Enclosure

### PSH550-UPS

Enclosed 550 VA Power Supply, 120 Vac with Switch/Circuit Breaker. Kit Consisting of UPS Model UPS550, Enclosure Model MH3400-M1, and Power Control Center Model PSM2RB10.

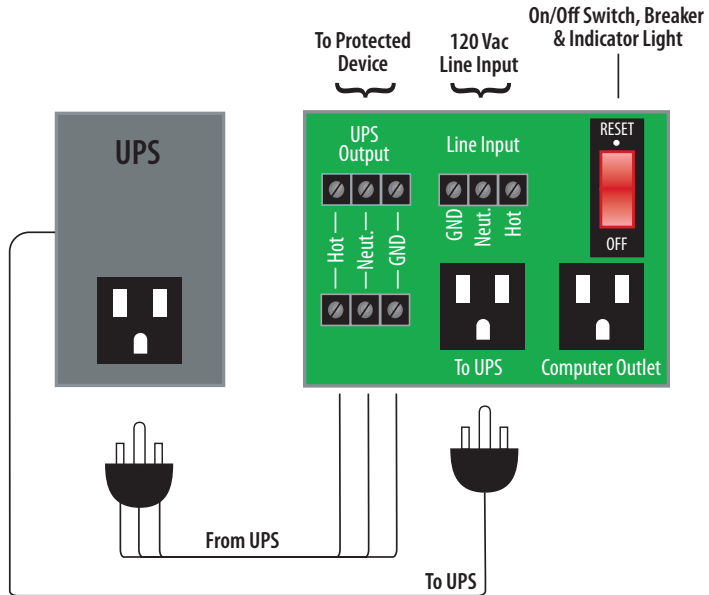

#### SPECIFICATIONS

- UPS: 550VA
- Backup Time: 3 Min. @ Full 550 VA Load  
13 Min. @ 1/2 Load
- Input: 120 Vac, 12 Amp
- Output: 120 Vac, 4.6 Amp, 330 Watt
- Frequency: 50/60 Hz
- Main Breaker ON/OFF: Switch / Breaker (10 Amp)
- Approvals: CE, RoHS
- Dimensions: 12.000" x 14.000" x 6.000"  
Metal Housing with Screw Cover
- Weight: 23.56 lbs.
- Temperature Rating of Housing & Control Center: -30 to 140° F
- Temperature Rating of UPS: 32 to 95° F
- UPS Transfer Time: 4ms

#### Notes:

» To order above model without UPS, so that any other commercial UPS with appropriate ratings for the circuit board may be used, order model PSH2RB10. To order interface board for replacement or for separate use, order model PSM2RB10. To order UPS, order model UPS550.

#### Notes