

**ENCLOSED UPS INTERFACE MODULE**

**PSH2C2RB10-L**

Enclosed 2.75" Track Mount Power Control Center, with 10 Amp Switch / Circuit Breaker, Two (2) 120 Vac Outlets, Terminals, 120 Vac Input. (Status Contacts)

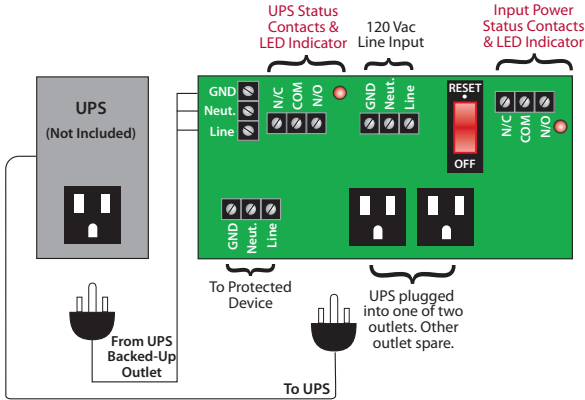

Shown Without Cover

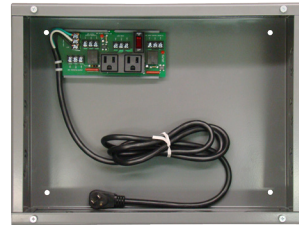

Shown With Cover



**SPECIFICATIONS**

- Operating Temperature:** -30 to 140° F
- Humidity Range:** 5 to 95% (noncondensing)
- Main Breaker ON/OFF:** Switch / Breaker (10 Amp)
- Approvals:** UL Listed, UL916, C-UL, CE, RoHS, NEMA 1
- Dimensions:** 12.000" x 16.000" x 6.000"  
Metal Housing with Screw Cover
- Weight:** 14.14 lbs.

- Line Input Status Contacts and UPS Output Status Contacts Rated:**
- 10 Amp @ 277 Vac General Use
  - 10 Amp @ 30 Vdc N/O
  - 7 Amp @ 30 Vdc N/C
  - 1/2 HP @ 125 Vac
  - 1/4 HP @ 277 Vac
  - 100 VA @ 120 Vac Ballast N/C
  - C300 Pilot Duty
  - 16.8 VA @ 24 Vac Pilot Duty

- Notes:**
- Track mounted interface board may be ordered separately as model PSMN2C2RB10, to be used with any commercial UPS with appropriate ratings for the circuit breaker.
  - Circuit breaker for short-circuit protection.
  - 14/3 Line Cord included (3').
  - Use with UPS devices rated 1000 VA or less.
    - Max. size: 8.000" x 16.000" x 5.500"
    - 120 Vac max., 600 W max., 8.3 Amp max.
  - UPS is not included.

**POWER CONTROL**