

Contents

How to Select the Butterfly Retrofit Solution pg 127
 Butterfly Valve Retrofit Actuators pg 128

Solutions for Specific Manufacturer and Part Number

Apollo pg 130
 Belimo pg 131
 Bray pg 133
 Centerline pg 135
 Challenger pg 138
 Chemtrol pg 139
 Dezurik pg 140
 Flowseal pg 141
 FNW pg 142
 Gruvlok pg 143
 Hammond pg 145
 Jamesbury pg 146
 Jenkins pg 147
 Johnson Controls pg 148
 Keystone pg 149
 Keystone K-LOK pg 149
 Metraflex pg 152
 Milwaukee pg 153
 Mueller pg 155
 Nibco pg 156
 PDC pg 157
 Quartermaster pg 158
 Victaulic pg 159
 Watts pg 161

Custom Butterfly Valve Retrofit Solutions, Instructions pg 162
 Custom Butterfly Valve Retrofit Solution Form pg 163
 Component Identification pg 164
 UFLK/UFSP Retrofit Solution (2-Way Valves) pg 167
 SY...Series Butterfly Retrofit Solution (2-Way Valves) pg 169
 UFLK/UFSP Retrofit Solution (3-Way Valves) pg 174
 SY...Series Butterfly Retrofit Solution (3-Way Valves) pg 177
 Valve Accessories pg 185
 Custom Ball Valve Retrofit Solution, Instructions pg 186
 Custom Ball Valve Retrofit Solution Form pg 187
 Custom Ball Valve Retrofit Solution, Dimensions pg 189
 Actuator/Valve Specification pg 199
 Terms and Conditions pg 203
 Platinum Distributors pg 205



Butterfly Valve:
UFLK Series **Linkage Solution**
 2-way Valves
 3-way Valves

Retrofit Solutions for Virtually any Valve

Manufacturers:

Butterfly: Bray, Centerline, Keystone, Flowseal and more

Control: On/Off, Floating, 2-10VDC
 Multi-Function Technology®
 Spring Return or
 Non-Spring Return

M40045 - 10/10 - SUBJECT TO CHANGE. © BELIMO AIRCONTROLS (USA), INC.



Dimensions with 3-Way Valve

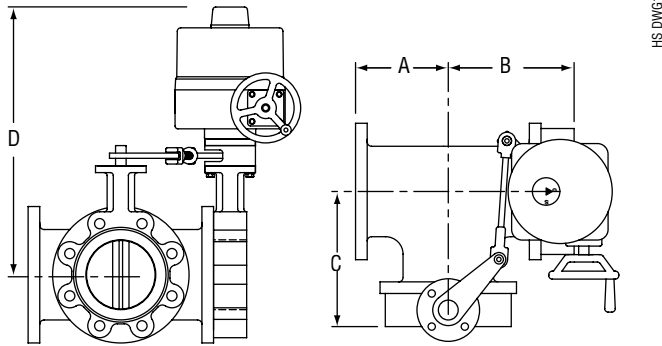

HS DWG15

Dimensions with 3-Way Valve

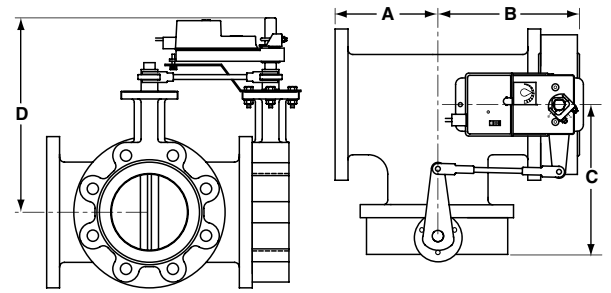

Single_Butterfly

Dimensions with 3-Way Valve

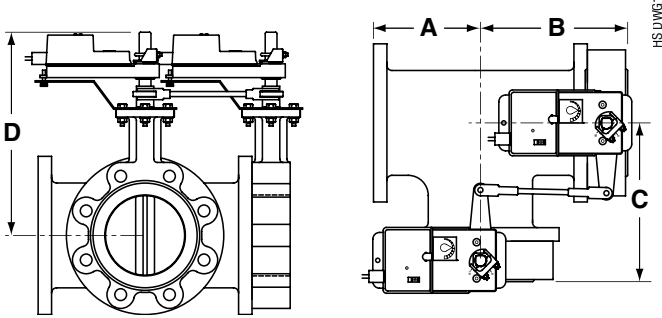

HS DWG11

Maximum Dimensions (Inches)

Size	B	C	D(Max)	Actuator
2"	6.15	6.15	20.25	AF
2"	6.15	6.15	15.5	SY1...
2"	6.15	6.15	20.25	SY2...
2½"	6.76	6.76	20.75	2*AF
2½"	6.76	6.76	16	SY1...
2½"	6.76	6.76	20.75	SY2...
3"	7.28	7.28	16.25	2*AF
3"	7.28	7.28	21	SY2...
4"	8.55	8.55	21.75	SY2...
5"	9.64	9.64	22.25	SY2...
5"	9.64	9.64	22.25	SY3...
6"	10.19	10.19	22.75	SY2...
6"	10.19	10.19	22.75	SY3...
8"	11.37	11.37	24.25	SY3...
8"	11.37	11.37	29	SY4...
10"	13.58	13.58	30	SY4...
12"	15.01	15.01	32	SY4...
12"	15.01	15.01	32	SY5...
14"	17.02	17.02	33	SY6...
16"	18.39	18.39	38.5	SY7...
18"	20.63	20.63	39.5	SY9...
20"	23	23	41.5	SY9...
24"	27.9	27.9	53.25	SY12...

Application Notes

1. Kits dimensions are approximate
2. Custom kits may be taller and varies by application needs
3. Dimension "D" allows for actuator removal without the need to remove the valve from the pipe.
4. Dual actuated valves have single actuators mounted on each valve shaft.

M40045 - 10/10 - SUBJECT TO CHANGE. © BELIMO AIRCONTROLS (USA), INC.

How to select a Butterfly Valve Retrofit Solution

Follow the four steps listed below when ordering a butterfly valve retrofit kit.

Example: Centerline C200 Series, 2½" valve, using a **Non-Spring Return** Belimo actuator.

- 1** Identify the **Valve Manufacturer, Valve Series** and **Valve Size**.
- 2** Determine the type of actuator you require: Belimo Spring Return, Non-Spring or SY Series Industrial. Belimo Spring and Non-Spring actuators are typically only available on smaller sizes.
Look at the solution using the Non-Spring Return Belimo Actuator. Looking at the **UFLK3500**, the **GM** Series actuator will provide a **200 psi close-off** for the **2½" valve** with **Non-Spring Return** actuation.
- 3** Use the actuator listings to make your final actuator selection. Decide between **GMX24-3-X1** and **GMX24-MFT-X1**.
ACTUATOR NOT INCLUDED IN THE LIST PRICE OF THE LINKAGE.

- 4** HOW TO ORDER: **Item 1 1pc UFLK3500**
Item 2 1pc GMX24-MFT-X1



1 Select linkage solution based on the **Valve Number, Configuration, and Size**; select the proper **Linkage Solution** for your valve.

EXAMPLE PAGE

Centerline

C200 Round Top Series Butterfly Valves
Linkage/Actuator Selection Guide

Valve Body Model	Valve Configuration	Size	Failsafe	Close-Off psi	Belimo Actuator Series (Sold Separately)	Belimo Linkage	
C200 Round Top Series Butterfly Valves	2-way	2"	No	200	AM	UFLK3500	
			Yes	200	AF	UFLK3500	
		2½"	No	200	GM	UFLK3500	
			Yes	200	2*AF	UFLK3502	
		3"	No	200	GM	UFLK3500	
			Yes	200	2*AF	UFLK3502	
	2-way	2-way	2"	No	200	SY1	UFLK3538
				Yes	200	SY2	UFLK3540
			2½"	No	200	GM	UFLK3500
				Yes	200	2*AF	UFLK3502
			3"	No	200	GM	UFLK3500
				Yes	200	2*AF	UFLK3502

UFLK1300

Example: **Centerline C200 Series, 2½" valve** using a **non-spring return** Belimo actuation.

Choose correct linkage **UFLK3500**.

- 2** Verify close-off is suitable for application.
Looking at the **UFLK3500**, the **GM** Series actuator will provide **200 psi close-off** for the **2½" valve**.

MODEL	Non-Spring Return Actuators					
	Control Input	Feedback	Power Supply	Running Time(s) [Default]	VA Rating	Aux. Switch
BASIC PRODUCTS						
GMB24-3-X1	On/Off, Floating Point	Add-on	24 VAC/DC	150 seconds	6	Add-on
GMB24-SR	2-10 VDC (4-20mA*)	2-10 VDC	24 VAC/DC	150 seconds	6.5	Add-on
CUSTOMIZE IT						
GMX24-3	On/Off, Floating Point	Add on	24 VAC/DC	150 seconds	7	Add-on
GMX24-SR	2-10 VDC (4-20mA*)	2-10 VDC	24 VAC/DC	150 seconds	6.5	Add-on
GMX24-PC	0-20 V Phasecut	2-10 VDC	24 VAC/DC	150 seconds	7	Add-on
GMX24-MFT-X1	Various	Various	24 VAC/DC	Various	7	Add-on
GMX24-MFT95-X1	0 to 135 Ω	2-10 VDC	24 VAC/DC	150 seconds	7	Add-on
GMX120-3	On/Off, Floating Point	Add on	100-240 VAC	150 seconds	9	Add-on

‡ For applications that require more torque the GMB Series can be dual mounted. A maximum of 2 GMB/X... Series actuators can be mechanically connected to one damper or valve shaft. The torque is 640 in-lb. *With the 500 Ω resistor added.

- 3** Select actuator based on needed control type.
Decide between **GMB24-3-X1** and **GMX24-MFT-X1**.

Complete Ordering Example:

- 4** Item 1: **UFLK3500**
Item 2: **GMX24-MFT-X1**

Butterfly Valve Retrofit Actuators

Actuator Selection Guide



SY Series Actuators

SERIES	MODEL	TORQUE	RUN TIME(S) 90°@60Hz	POWER SUPPLY	DUTY CYCLE	CONTROL			FEEDBACK
						PROPORTIONAL	3 POINT	ON/OFF	
SY9	SY9-110	2000 Nm / 17800 in-lb	58 seconds	120 VAC ±10%, 50/60 Hz	30%		•	•	none, opt 1k
	SY9-220	2000 Nm / 17800 in-lb	58 seconds	230 VAC ±10%, 50/60 Hz	30%		•	•	none, opt 1k
	SY9-120MFT	2000 Nm / 17800 in-lb	58 seconds	120 VAC ±10%, 50/60 Hz	75%	•			2-10 VDC/4-20 mA
	SY9-230MFT	2000 Nm / 17800 in-lb	58 seconds	230 VAC ±10%, 50/60 Hz	75%	•			2-10 VDC/4-20 mA
SY10	SY10-110	2500 Nm / 22250 in-lb	58 seconds	120 VAC ±10%, 50/60 Hz	30%		•	•	none, opt 1k
	SY10-220	2500 Nm / 22250 in-lb	58 seconds	230 VAC ±10%, 50/60 Hz	30%		•	•	none, opt 1k
	SY10-120MFT	2500 Nm / 22250 in-lb	58 seconds	120 VAC ±10%, 50/60 Hz	75%	•			2-10 VDC/4-20 mA
	SY10-230MFT	2500 Nm / 22250 in-lb	58 seconds	230 VAC ±10%, 50/60 Hz	75%	•			2-10 VDC/4-20 mA
SY11	SY11-110	3000 Nm / 26700 in-lb	58 seconds	120 VAC ±10%, 50/60 Hz	30%		•	•	none, opt 1k
	SY11-220	3000 Nm / 26700 in-lb	58 seconds	230 VAC ±10%, 50/60 Hz	30%		•	•	none, opt 1k
	SY11-120MFT	3000 Nm / 26700 in-lb	58 seconds	120 VAC ±10%, 50/60 Hz	75%	•			2-10 VDC/4-20 mA
	SY11-230MFT	3000 Nm / 26700 in-lb	58 seconds	230 VAC ±10%, 50/60 Hz	75%	•			2-10 VDC/4-20 mA
SY12	SY12-110	3500 Nm / 31150 in-lb	58 seconds	120 VAC ±10%, 50/60 Hz	30%		•	•	none, opt 1k
	SY12-220	3500 Nm / 31150 in-lb	58 seconds	230 VAC ±10%, 50/60 Hz	30%		•	•	none, opt 1k
	SY12-120MFT	3500 Nm / 31150 in-lb	58 seconds	120 VAC ±10%, 50/60 Hz	75%	•			2-10 VDC/4-20 mA
	SY12-230MFT	3500 Nm / 31150 in-lb	58 seconds	230 VAC ±10%, 50/60 Hz	75%	•			2-10 VDC/4-20 mA

Proportional actuators will accept 0-10 VDC, 2-10 VDC, or 4-20 mA control signals as standard.

All SY actuators are non-spring return, but can be used with NSV-SY back up systems for fail-safe applications.

These products carry a two year warranty when sold as part of an assembly or with a UFLK retrofit kit.

ROTARY ACTUATORS

SERIES	MODEL	Spring Return	Electronic Fail Safe	Control Input	Feedback Position	Power Supply
AF Series*	AF24 US, AFB24	•		24 VAC/DC		24 VAC/DC
	AFX24-MFT-X1	•		Variable with MFT (VDC, PWM, Floating Pt., On/Off)	variable VDC	24 VAC/DC
AM Series*	AMB24-3-X1			24 VAC/DC		24 VAC/DC
	AMX24-MFT-X1			Variable with MFT (VDC, PWM, Floating Pt., On/Off)	variable VDC	24 VAC/DC
GM Series*	GMB24-3-X1			24 VAC/DC		24 VAC/DC
	GMX24-MFT-X1			Variable with MFT (VDC, PWM, Floating Pt., On/Off)	variable VDC	24 VAC/DC
GK Series*	GKB24-3-X1		•	24 VAC/DC		24 VAC/DC
	GKX24-MFT-X1		•	Variable with MFT (VDC, PWM, Floating Pt., On/Off)	variable VDC	24 VAC/DC

*Please consult the Damper sections for a full list of product offerings. Standard run times should be considered in the selection. All air side products are applicable for retrofit kits.

Select "X1" actuators come with a handle.

MULTI-FUNCTION TECHNOLOGY

ROTARY ACTUATOR CODES	P-CODE		Control Input	Running Time	Built-in Feedback
	P-10001	A01	2-10 VDC	150 seconds	2-10 VDC
	P-10002	A02	0-10 VDC	150 seconds	0-10 VDC
	P-10028	A28	0-10 VDC	150 seconds	0-10 VDC
	P-10063	A63	0.5-4.5 VDC	150 seconds	0.5-4.5 VDC
	P-10064	A64	5.5-10 VDC	150 seconds	5.5-10 VDC
	P-20002	W02	0.02-5.00 seconds PWM	150 seconds	2-10 VDC
	P-20003	W03	0.10-25.5 seconds PWM	150 seconds	2-10 VDC
	P-30001	F01	Floating Pt.	150 seconds	2-10 VDC
	P-40002	J02	On/Off	150 seconds	2-10 VDC

SY MULTI-FUNCTION TECHNOLOGY

Description	MFT-CODE	Control Input	Built-in Feedback	Loss of Signal	Running Time
MFT	ACE	2...10V	2...10V	stop	actuator(s) constant
MFT	ACF	0.5...10V	0.5...10V	stop	actuator(s) constant
MFT	ACG	4...20mA	4...20mA	stop	actuator(s) constant
MFT	ACH	4...20mA	2...10V	stop	actuator(s) constant
MFT	ACJ	2...10V	2...10V	open	actuator(s) constant
MFT	ACK	0.5...10V	0.5...10V	open	actuator(s) constant
MFT	ACL	4...20mA	4...20mA	open	actuator(s) constant
MFT	ACM	4...20mA	2...10V	open	actuator(s) constant
MFT	ACN	2...10V	2...10V	close	actuator(s) constant
MFT	ACP	0.5...10V	0.5...10V	close	actuator(s) constant
MFT	ACR	4...20mA	4...20mA	close	actuator(s) constant
MFT	ACS	4...20mA	2...10V	close	actuator(s) constant

All other configurations carry a \$34.00 list price.

Standard delivery may vary, please consult your customer service representative for the latest lead time(s).

800-543-9038 USA

866-805-7089 CANADA

203-791-8396 LATIN AMERICA

Valve Body Model	Valve Configuration	Size	Failsafe	Close-Off psi	Belimo Actuator Series (Sold Separately)	Belimo Linkage	
27 Series Butterfly Valves (Pinned Shaft Type)	2-way	2"	No	150	GM	UFLK3100	
					SY1	UFLK3122	
					SY2	UFLK3124	
			Yes	150	2*AF	UFLK3102	
			GK		UFLK3100		
			2*GM		UFLK3102		
		2½"	No	150	2*GM	UFLK3102	
					SY2	UFLK3124	
			Yes	150	2*GK	UFLK3102	
			No		150	2*GM	UFLK3102
		3"	No	150		2*GM	UFLK3102
					SY2	UFLK3124	
			Yes	150	2*GK	UFLK3102	
			No		150	2*GM	UFLK3108
		4"	No	150		SY2	UFLK3126
					2*GK	UFLK3108	
		5"	No	150	SY3	UFLK3128	
		6"	No	150	SY3	UFLK3130	
	8"	No	150	SY4	UFLK3132		
	10"	No	150	SY4	UFLK3132		
	12"	No	150	SY6	UFLK3132		
	3-way	2"	No	150	GM	UFLK6100	
						SY2	UFLK6122
						2*AF	UFLK6102
			Yes	150	GK	UFLK6100	
			No		150	2*GM	UFLK6102
			SY2			UFLK6122	
			Yes	150	2*GK	UFLK6102	
			No		150	2*GM	UFLK6102
		2½"	No	150		SY2	UFLK6122
			2*GK		UFLK6102		
3"		No	150	2*GM	UFLK6102		
				SY2	UFLK6122		
		Yes	150	2*GK	UFLK6102		
		No		150	SY3	UFLK6124	
4"		No	150		SY4	UFLK6126	
5"		No	150	SY4	UFLK6128		
6"		No	150	SY4	UFLK6130		
8"		No	150	SY4	UFLK6130		
10"	No	150	SY6	UFLK6132			
12"	No	150	SY7	UFLK6134			

All close-off pressures listed are approximate and based on valve condition and application.

M40045 - 10/10 - Subject to change. © Belimo Aircontrols (USA), Inc.

Custom Butterfly Valve Retrofit Solutions

UFSP Series Butterfly Valve



3-way Single Actuator

Generic – Must complete BFV Retrofit Form

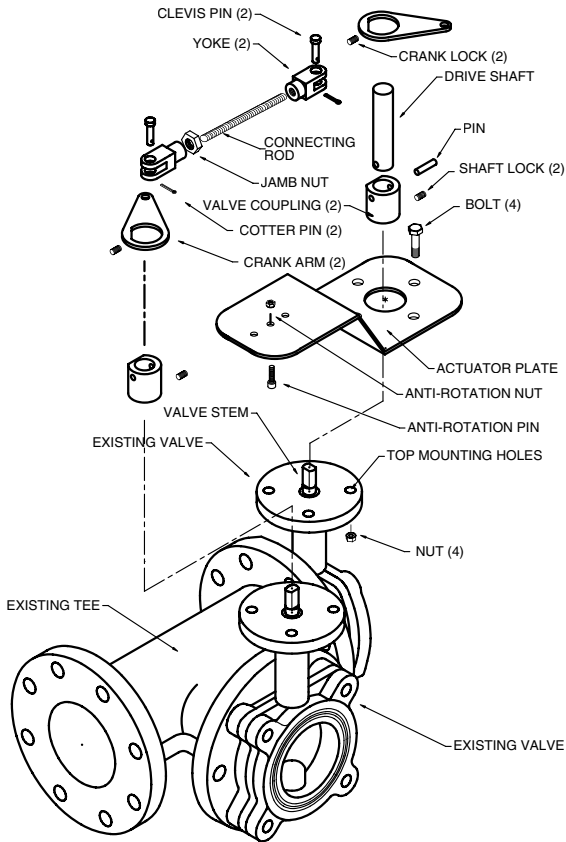

UFSP002

3-way Dual Actuator

Generic – Must complete BFV Retrofit Form

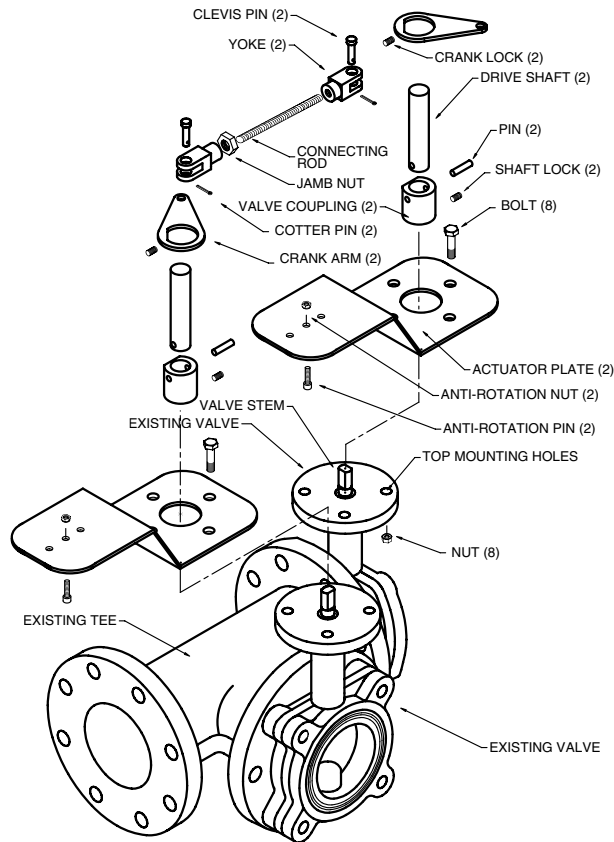

UFSP0010

NOTE: 3-way bracket configuration shown is only one of many possible arrangements.

M40045 - 10/10 - SUBJECT TO CHANGE. © BELIMO AIRCONTROLS (USA), INC.

Assembly Sequence for Existing Valves

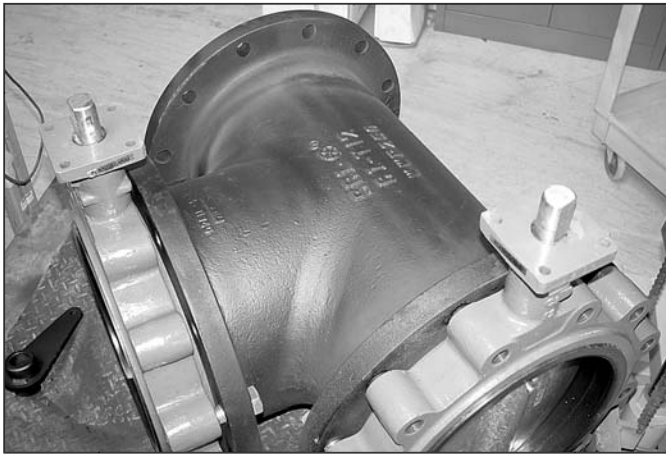

The valves should be stripped down to their basic form, as shown. Remove all other linkage components before starting the assembly sequence below. The linkage components have been designed to attach to the valve in this state, rather than to any existing hardware.

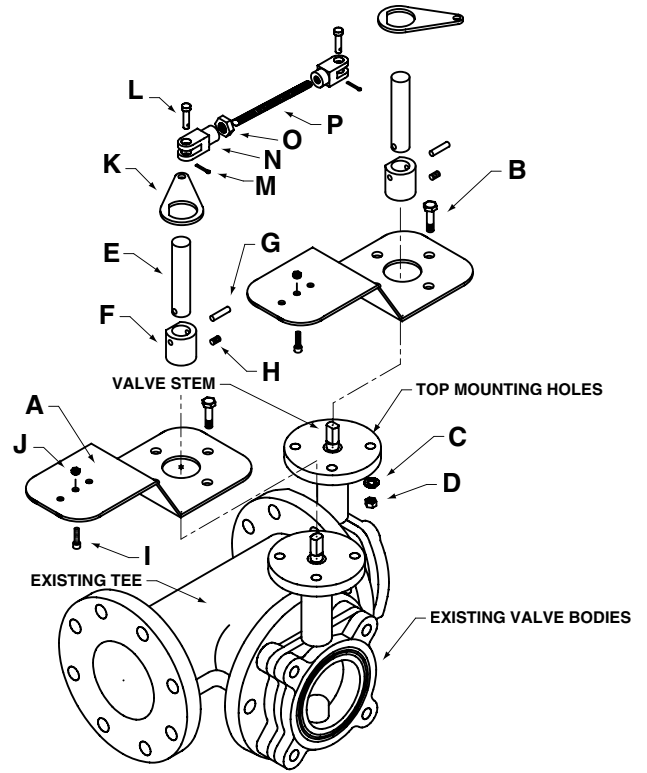

Please refer to the above exploded view above when following the assembly procedure, to better identify which parts are being addressed in each step. Additionally, you need to determine the configuration of the valve you are trying to retrofit, using one of the three diagrams below:

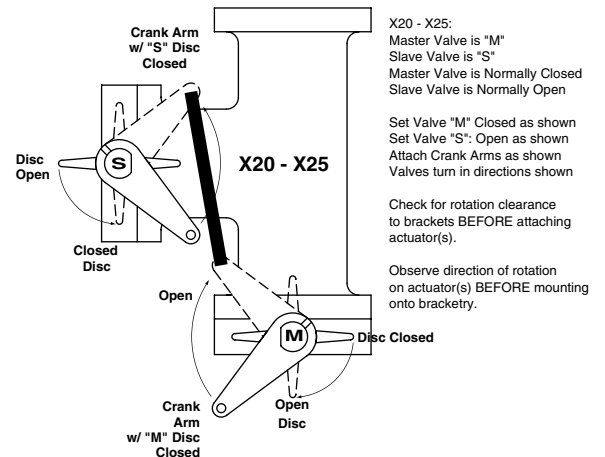
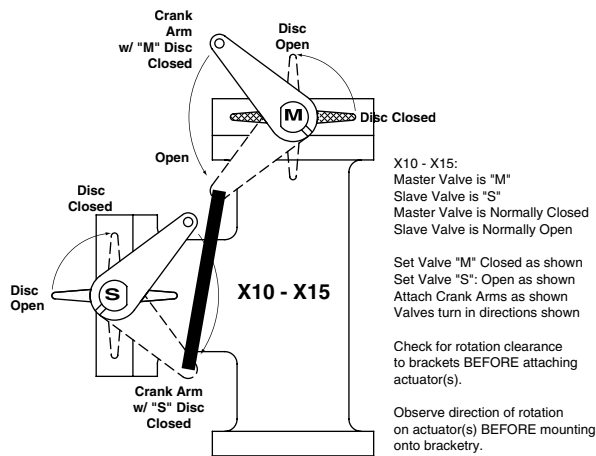

Depending on the orientation of the tee assembly, if the valves are mounted on the TOP and BRANCH positions (tee mounted vertically), or on the LEFT and BRANCH positions (tee mounted horizontally) you will refer to configuration codes X10-X15.

If the valves are mounted on the BOTTOM and BRANCH positions (tee mounted vertically), or on the RIGHT and BRANCH positions (tee mounted horizontally) you will refer to configuration codes X20-X25.

M40045 - 10/10 - SUBJECT TO CHANGE. © BELIMO AIRCONTROLS (USA), INC.

UFLK/UFSP Series Butterfly Valve Retrofit Solution

Retrofitting 3-way Valves with Belimo Direct Coupled Actuator(s)



Assembly Sequence for Existing Valves

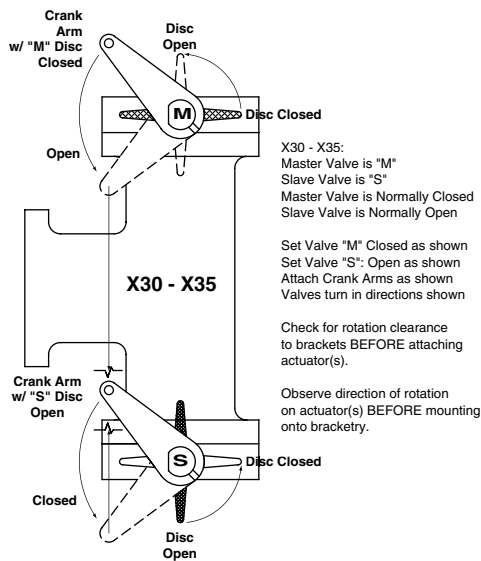

If the valves are mounted on the TOP and BOTTOM positions (tee mounted vertically), or on the LEFT and RIGHT positions (tee mounted horizontally) you will refer to configuration codes X30-X35

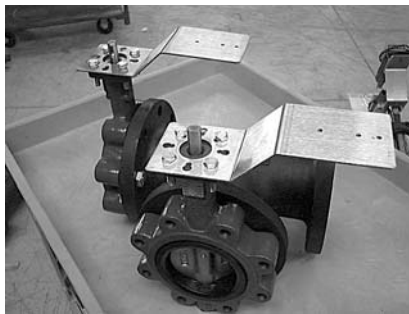

Step 1) Assemble the actuator mounting bracket(s) (A) to the top of the valve actuator mounting pad(s) using the supplied bolts (B), lock washers (C) and nuts (D). The bracket(s) need to be oriented so that they are parallel to the

RUN of the tee, unless you have configuration codes X30-35, in which case the bracket(s) must be mounted parallel to the BRANCH of the tee.

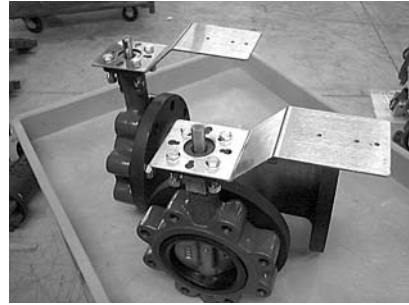

Step 2) Refer to the three configuration drawing types on page 9 of the Butterfly Valve O & M (71150-00001) and position the valve discs as instructed. For example, if you have a Configuration Type A tee assembly, you will OPEN the master

valve (A), and CLOSE the slave valve (B). During the assembly procedure, CLOSED and OPEN means 0 degrees and 90 degrees respectively. Failure to position the discs into their quadrants will result in improper operation and performance of the retrofit kit. Most manufacturers mark the TOP of the valve stem with a slot which indicates the disc angle.

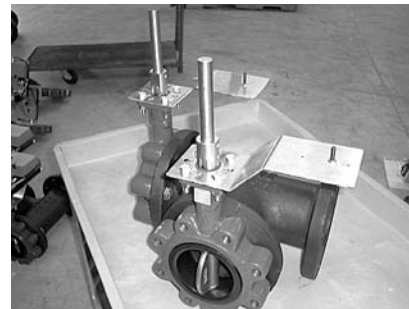

Step 3) Slide the drive pin assembly, consisting of the drive shaft(s) (E), the valve shaft couplings (F), the mating pins (G), and the setscrews (H), over the valve shafts. It may be necessary to back out the set screws (H) a few turns to make

sure there is clearance in the coupling pockets (bottom of (F) for the valve shafts. Drive shafts (E) should be concentric and parallel with the valve shafts so there is no binding. Any angular alignment MUST be corrected before moving on to the next step.

Note: Belimo recommends drilling a pilot hole into the shaft. This will ensure the set screw (H) sits flat. Failure to do this may result in the coupler (F) slipping over time.

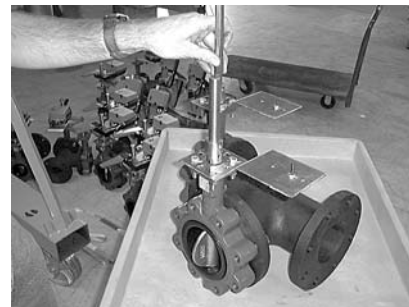

Step 4) Mark the top of each drive shaft (E) to indicate the disc position. Typically, this is done using a chisel to punch a line PARALLEL to the valve disc to make it easier to identify the disc position during the assembly process.

M40045 - 10/10 - SUBJECT TO CHANGE. © BELIMO AIRCONTROLS (USA), INC.



Step 5) Refer to the three configuration drawing types and position the crank arms (K) as instructed. Slide the crank arms over valve couplings (F), and position just below the top edge of the couplings. Tighten set screws (H) to affix the crank arms (K) to the couplings (F).

* On larger units it may be necessary to spot weld the crankarm to the coupler.

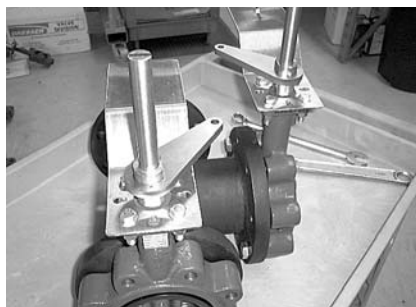

Step 6) Once the crank arms (K) are attached to the assembly, again refer to the drawings to make sure the entire assembly matches the corresponding configuration type.



Step 7) The connecting rod (P) is supplied long enough to meet all configuration types, and will have to be modified in the field to properly fit your assembly. Connecting rod (P) is furnished with jamb nut (O), yoke (N), clevis pin

(L) and cotter key (M) attached to one end, and the second yoke assembly attached to the opposite end. Remove the yoke assembly from the end without the jamb nut (O). Remove the cotter pins (M) and clevis pins (L) from both yokes (N). With the valve discs and crank arms (K) properly positioned, attach the end of the connecting rod (P) with the still attached yoke (N), to one of the crank arms (K), and reinstall clevis pin (L) to retain its position. Attach the free yoke (N) to the second crank arm (K) and again use the clevis pin (L) to retain its position. Point the connecting rod (P) towards the second yoke and align the yoke (N) with the connecting rod (P). You will now have an idea of where to CUT the connecting rod (P) for a proper fit. The correct length is attained when the ENDS of the connection rod (P) are even with the INSIDE ends of the threads on the yokes (N). Be sure to tighten the jamb nut (O) after the proper length has been attained. Reinstall the cotter pins (M) in both clevis pins (L) and bend to retain.

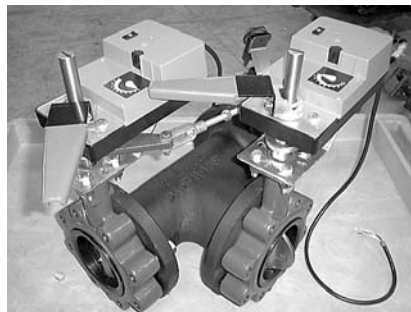

Step 8) Assemble the actuator(s) to the linkage by sliding the actuator shaft clamp over the kit drive shaft(s) (E). The actuator anti-rotation pin(s) (I) should already be positioned in the correct hole for the actuator, but they can be moved to

accommodate AM, GM or AF series actuators. Make sure the anti-rotation pin nut(s) (J) is tight. Make sure the bottom of the actuator(s) is PARALLEL to the mounting plate (A) when tightening the actuator clamp nuts. If this is not checked, it is possible that binding could cause erratic movement of the valve disc due to reduced torque transmission to the valve shaft(s). For AF series actuators, release the pre-load on the spring before tightening the clamp nuts, as the valve discs have already been positioned at their full travel stops in step 2 above.

Step 9) Keep in mind that for dual actuator retrofits, the actuators turn in OPPOSITE directions. AF series actuators have to be mounted with opposite sides UP, and GM series actuators will need to have their 0/1 acting switches changed so one is opposite the other.