

Contents

How to Select the Butterfly Retrofit Solution pg 127
 Butterfly Valve Retrofit Actuators pg 128

Solutions for Specific Manufacturer and Part Number

Apollo pg 130
 Belimo pg 131
 Bray pg 133
 Centerline pg 135
 Challenger pg 138
 Chemtrol pg 139
 Dezurik pg 140
 Flowseal pg 141
 FNW pg 142
 Gruvlok pg 143
 Hammond pg 145
 Jamesbury pg 146
 Jenkins pg 147
 Johnson Controls pg 148
 Keystone pg 149
 Keystone K-LOK pg 149
 Metraflex pg 152
 Milwaukee pg 153
 Mueller pg 155
 Nibco pg 156
 PDC pg 157
 Quartermaster pg 158
 Victaulic pg 159
 Watts pg 161

Custom Butterfly Valve Retrofit Solutions, Instructions pg 162
 Custom Butterfly Valve Retrofit Solution Form pg 163
 Component Identification pg 164
 UFLK/UFSP Retrofit Solution (2-Way Valves) pg 167
 SY...Series Butterfly Retrofit Solution (2-Way Valves) pg 169
 UFLK/UFSP Retrofit Solution (3-Way Valves) pg 174
 SY...Series Butterfly Retrofit Solution (3-Way Valves) pg 177
 Valve Accessories pg 185
 Custom Ball Valve Retrofit Solution, Instructions pg 186
 Custom Ball Valve Retrofit Solution Form pg 187
 Custom Ball Valve Retrofit Solution, Dimensions pg 189
 Actuator/Valve Specification pg 199
 Terms and Conditions pg 203
 Platinum Distributors pg 205



Butterfly Valve:

UFLK Series **Linkage Solution**
 2-way Valves
 3-way Valves

Retrofit Solutions for Virtually any Valve

Manufacturers:

Butterfly: Bray, Centerline, Keystone, Flowseal and more

Control: On/Off, Floating, 2-10VDC
 Multi-Function Technology®
 Spring Return or
 Non-Spring Return

M40045 - 10/10 - SUBJECT TO CHANGE. © BELIMO AIRCONTROLS (USA), INC.



Dimensions with 3-Way Valve

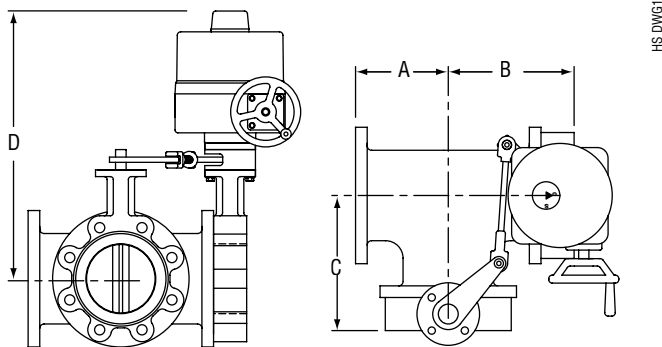

Dimensions with 3-Way Valve

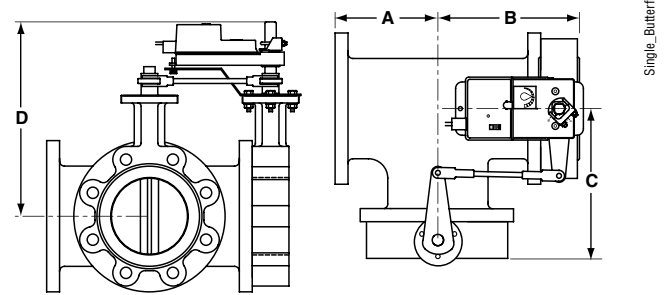

Dimensions with 3-Way Valve

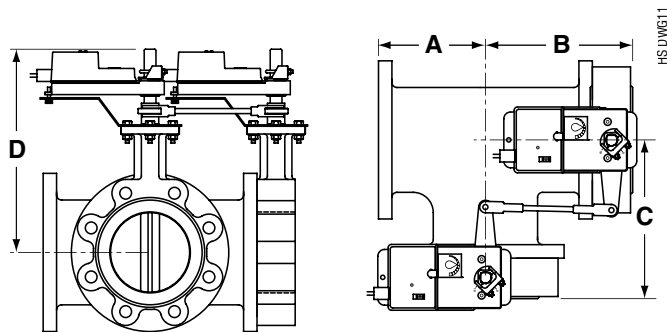

Maximum Dimensions (Inches)

Size	B	C	D(Max)	Actuator
2"	6.15	6.15	20.25	AF
2"	6.15	6.15	15.5	SY1...
2"	6.15	6.15	20.25	SY2...
2½"	6.76	6.76	20.75	2*AF
2½"	6.76	6.76	16	SY1...
2½"	6.76	6.76	20.75	SY2...
3"	7.28	7.28	16.25	2*AF
3"	7.28	7.28	21	SY2...
4"	8.55	8.55	21.75	SY2...
5"	9.64	9.64	22.25	SY2...
5"	9.64	9.64	22.25	SY3...
6"	10.19	10.19	22.75	SY2...
6"	10.19	10.19	22.75	SY3...
8"	11.37	11.37	24.25	SY3...
8"	11.37	11.37	29	SY4...
10"	13.58	13.58	30	SY4...
12"	15.01	15.01	32	SY4...
12"	15.01	15.01	32	SY5...
14"	17.02	17.02	33	SY6...
16"	18.39	18.39	38.5	SY7...
18"	20.63	20.63	39.5	SY9...
20"	23	23	41.5	SY9...
24"	27.9	27.9	53.25	SY12...

Application Notes

1. Kits dimensions are approximate
2. Custom kits may be taller and varies by application needs
3. Dimension "D" allows for actuator removal without the need to remove the valve from the pipe.
4. Dual actuated valves have single actuators mounted on each valve shaft.

M40045 - 10/10 - SUBJECT TO CHANGE. © BELIMO AIRCONTROLS (USA), INC.

How to select a Butterfly Valve Retrofit Solution

Follow the four steps listed below when ordering a butterfly valve retrofit kit.

Example: Centerline C200 Series, 2½” valve, using a **Non-Spring Return** Belimo actuator.

- 1** Identify the **Valve Manufacturer, Valve Series** and **Valve Size**.
- 2** Determine the type of actuator you require: Belimo Spring Return, Non-Spring or SY Series Industrial. Belimo Spring and Non-Spring actuators are typically only available on smaller sizes.
Look at the solution using the Non-Spring Return Belimo Actuator. Looking at the **UFLK3500**, the **GM** Series actuator will provide a **200 psi close-off** for the **2½” valve** with **Non-Spring Return** actuation.
- 3** Use the actuator listings to make your final actuator selection. Decide between **GMX24-3-X1** and **GMX24-MFT-X1**.
ACTUATOR NOT INCLUDED IN THE LIST PRICE OF THE LINKAGE.

- 4** HOW TO ORDER: **Item 1 1pc UFLK3500**
Item 2 1pc GMX24-MFT-X1



1 Select linkage solution based on the **Valve Number, Configuration, and Size**; select the proper **Linkage Solution** for your valve.

EXAMPLE PAGE

Centerline

C200 Round Top Series Butterfly Valves
Linkage/Actuator Selection Guide

Valve Body Model	Valve Configuration	Size	Failsafe	Close-Off psi	Belimo Actuator Series (Sold Separately)	Belimo Linkage
C200 Round Top Series Butterfly Valves	2-way	2"	No	200	AM	UFLK3500
			Yes	200	AF	UFLK3500
		2½"	No	200	GM	UFLK3500
			Yes	200	2*AF	UFLK3502
		3"	No	200	GM	UFLK3500
			Yes	200	2*AF	UFLK3502
	2-way	2"	No	200	SY1	UFLK3538
			Yes	200	SY2	UFLK3540
		2½"	No	200	GM	UFLK3500
			Yes	200	2*AF	UFLK3502
		3"	No	200	GM	UFLK3500
			Yes	200	2*AF	UFLK3502

UFLK1300

Example: **Centerline C200 Series, 2½” valve** using a **non-spring return** Belimo actuation.

Choose correct linkage **UFLK3500**.

- 2** Verify close-off is suitable for application.
Looking at the **UFLK3500**, the **GM** Series actuator will provide **200 psi close-off** for the **2½” valve**.

MODEL	Non-Spring Return Actuators					
	Control Input	Feedback	Power Supply	Running Time(s) [Default]	VA Rating	Aux. Switch
BASIC PRODUCTS						
GMB24-3-X1	On/Off, Floating Point	Add-on	24 VAC/DC	150 seconds	6	Add-on
GMB24-SR	2-10 VDC (4-20mA*)	2-10 VDC	24 VAC/DC	150 seconds	6.5	Add-on
CUSTOMIZE IT						
GMX24-3	On/Off, Floating Point	Add on	24 VAC/DC	150 seconds	7	Add-on
GMX24-SR	2-10 VDC (4-20mA*)	2-10 VDC	24 VAC/DC	150 seconds	6.5	Add-on
GMX24-PC	0-20 V Phasecut	2-10 VDC	24 VAC/DC	150 seconds	7	Add-on
GMX24-MFT-X1	Various	Various	24 VAC/DC	Various	7	Add-on
GMX24-MFT95-X1	0 to 135 Ω	2-10 VDC	24 VAC/DC	150 seconds	7	Add-on
GMX120-3	On/Off, Floating Point	Add on	100-240 VAC	150 seconds	9	Add-on

‡ For applications that require more torque the GMB Series can be dual mounted. A maximum of 2 GMB/X... Series actuators can be mechanically connected to one damper or valve shaft. The torque is 640 in-lb.
*With the 500 Ω resistor added.

- 3** Select actuator based on needed control type.
Decide between **GMB24-3-X1** and **GMX24-MFT-X1**.

Complete Ordering Example:

- 4** Item 1: **UFLK3500**
Item 2: **GMX24-MFT-X1**

SY Series Actuators

SERIES	MODEL	TORQUE	RUN TIME(S) 90°@60Hz	POWER SUPPLY	DUTY CYCLE	CONTROL			FEEDBACK
						PROPORTIONAL	3 POINT	ON/OFF	
SY1	SY1-110	35 Nm / 310 in-lb	12 seconds	120 VAC ±10%, 50/60 Hz	30%		•	•	none, opt 1k
	SY1-24	35 Nm / 310 in-lb	12 seconds	24 VAC ±10%, 50/60 Hz	30%		•	•	none, opt 1k
	SY1-220	35 Nm / 310 in-lb	12 seconds	230 VAC ±10%, 50/60 Hz	30%		•	•	none, opt 1k
	SY1-110P	35 Nm / 310 in-lb	12 seconds	120 VAC ±10%, 50/60 Hz	75%	•			2-10 VDC/4-20 mA
	SY1-24P	35 Nm / 310 in-lb	12 seconds	24 VAC ±10%, 50/60 Hz	75%	•			2-10 VDC/4-20 mA
SY1-220P	35 Nm / 310 in-lb	12 seconds	230 VAC ±10%, 50/60 Hz	75%	•			2-10 VDC/4-20 mA	
SY2	SY2-110	90 Nm / 801 in-lb	15 seconds	120 VAC ±10%, 50/60 Hz	30%		•	•	none, opt 1k
	SY2-24	90 Nm / 801 in-lb	15 seconds	24 VAC ±10%, 50/60 Hz	30%		•	•	none, opt 1k
	SY2-220	90 Nm / 801 in-lb	15 seconds	230 VAC ±10%, 50/60 Hz	30%		•	•	none, opt 1k
	SY2-120MFT	90 Nm / 801 in-lb	15 seconds	120 VAC ±10%, 50/60 Hz	75%	•			2-10 VDC/4-20 mA
	SY2-24MFT	90 Nm / 801 in-lb	15 seconds	24 VAC ±10%, 50/60 Hz	75%	•			2-10 VDC/4-20 mA
SY2-230MFT	90 Nm / 801 in-lb	15 seconds	230 VAC ±10%, 50/60 Hz	75%	•			2-10 VDC/4-20 mA	
SY3	SY3-110	150 Nm / 1335 in-lb	22 seconds	120 VAC ±10%, 50/60 Hz	30%		•	•	none, opt 1k
	SY3-24	150 Nm / 1335 in-lb	22 seconds	24 VAC ±10%, 50/60 Hz	30%		•	•	none, opt 1k
	SY3-220	150 Nm / 1335 in-lb	22 seconds	230 VAC ±10%, 50/60 Hz	30%		•	•	none, opt 1k
	SY3-24MFT	150 Nm / 1335 in-lb	22 seconds	120 VAC ±10%, 50/60 Hz	75%	•			2-10 VDC/4-20 mA
	SY3-120MFT	150 Nm / 1335 in-lb	22 seconds	120 VAC ±10%, 50/60 Hz	75%	•			2-10 VDC/4-20 mA
SY3-230MFT	150 Nm / 1335 in-lb	22 seconds	230 VAC ±10%, 50/60 Hz	75%	•			2-10 VDC/4-20 mA	
SY4	SY4-110	400 Nm / 3560 in-lb	16 seconds	120 VAC ±10%, 50/60 Hz	30%		•	•	none, opt 1k
	SY4-24	400 Nm / 3560 in-lb	16 seconds	24 VAC ±10%, 50/60 Hz	30%		•	•	none, opt 1k
	SY4-220	400 Nm / 3560 in-lb	16 seconds	230 VAC ±10%, 50/60 Hz	30%		•	•	none, opt 1k
	SY4-24MFT	400 Nm / 3560 in-lb	16 seconds	120 VAC ±10%, 50/60 Hz	75%	•			2-10 VDC/4-20 mA
	SY4-120MFT	400 Nm / 3560 in-lb	16 seconds	120 VAC ±10%, 50/60 Hz	75%	•			2-10 VDC/4-20 mA
SY4-230MFT	400 Nm / 3560 in-lb	16 seconds	230 VAC ±10%, 50/60 Hz	75%	•			2-10 VDC/4-20 mA	
SY5	SY5-110	500 Nm / 4450 in-lb	22 seconds	120 VAC ±10%, 50/60 Hz	30%		•	•	none, opt 1k
	SY5-24	500 Nm / 4450 in-lb	22 seconds	24 VAC ±10%, 50/60 Hz	30%		•	•	none, opt 1k
	SY5-220	500 Nm / 4450 in-lb	22 seconds	230 VAC ±10%, 50/60 Hz	30%		•	•	none, opt 1k
	SY5-24MFT	500 Nm / 4450 in-lb	22 seconds	120 VAC ±10%, 50/60 Hz	75%	•			2-10 VDC/4-20 mA
	SY5-120MFT	500 Nm / 4450 in-lb	22 seconds	120 VAC ±10%, 50/60 Hz	75%	•			2-10 VDC/4-20 mA
SY5-230MFT	500 Nm / 4450 in-lb	22 seconds	230 VAC ±10%, 50/60 Hz	75%	•			2-10 VDC/4-20 mA	
SY6	SY6-110	650 Nm / 5785 in-lb	28 seconds	120 VAC ±10%, 50/60 Hz	30%		•	•	none, opt 1k
	SY6-220	650 Nm / 5785 in-lb	28 seconds	230 VAC ±10%, 50/60 Hz	30%		•	•	none, opt 1k
	SY6-120MFT	650 Nm / 5785 in-lb	28 seconds	120 VAC ±10%, 50/60 Hz	75%	•			2-10 VDC/4-20 mA
	SY6-230MFT	650 Nm / 5785 in-lb	28 seconds	230 VAC ±10%, 50/60 Hz	75%	•			2-10 VDC/4-20 mA
SY7	SY7-110	1000 Nm / 8900 in-lb	46 seconds	120 VAC ±10%, 50/60 Hz	30%		•	•	none, opt 1k
	SY7-220	1000 Nm / 8900 in-lb	46 seconds	230 VAC ±10%, 50/60 Hz	30%		•	•	none, opt 1k
	SY7-120MFT	1000 Nm / 8900 in-lb	46 seconds	120 VAC ±10%, 50/60 Hz	75%	•			2-10 VDC/4-20 mA
	SY7-230MFT	1000 Nm / 8900 in-lb	46 seconds	230 VAC ±10%, 50/60 Hz	75%	•			2-10 VDC/4-20 mA
SY8	SY8-110	1500 Nm / 13350 in-lb	46 seconds	120 VAC ±10%, 50/60 Hz	30%		•	•	none, opt 1k
	SY8-220	1500 Nm / 13350 in-lb	46 seconds	230 VAC ±10%, 50/60 Hz	30%		•	•	none, opt 1k
	SY8-120MFT	1500 Nm / 13350 in-lb	46 seconds	120 VAC ±10%, 50/60 Hz	75%	•			2-10 VDC/4-20 mA
	SY8-230MFT	1500 Nm / 13350 in-lb	46 seconds	230 VAC ±10%, 50/60 Hz	75%	•			2-10 VDC/4-20 mA

Proportional actuators will accept 0-10 VDC, 2-10 VDC, or 4-20 mA control signals as standard.

All SY actuators are non-spring return, but can be used with NSV-SY back up systems for fail-safe applications.

These products carry a two year warranty when sold as part of an assembly or with a UFLK retrofit kit.

M40045 - 10/10 - SUBJECT TO CHANGE. © BELIMO AIRCONTROLS (USA), INC.

Butterfly Valve Retrofit Actuators

Actuator Selection Guide



SY Series Actuators

SERIES	MODEL	TORQUE	RUN TIME(S) 90°@60Hz	POWER SUPPLY	DUTY CYCLE	CONTROL			FEEDBACK
						PROPORTIONAL	3 POINT	ON/OFF	
SY9	SY9-110	2000 Nm / 17800 in-lb	58 seconds	120 VAC ±10%, 50/60 Hz	30%		•	•	none, opt 1k
	SY9-220	2000 Nm / 17800 in-lb	58 seconds	230 VAC ±10%, 50/60 Hz	30%		•	•	none, opt 1k
	SY9-120MFT	2000 Nm / 17800 in-lb	58 seconds	120 VAC ±10%, 50/60 Hz	75%	•			2-10 VDC/4-20 mA
	SY9-230MFT	2000 Nm / 17800 in-lb	58 seconds	230 VAC ±10%, 50/60 Hz	75%	•			2-10 VDC/4-20 mA
SY10	SY10-110	2500 Nm / 22250 in-lb	58 seconds	120 VAC ±10%, 50/60 Hz	30%		•	•	none, opt 1k
	SY10-220	2500 Nm / 22250 in-lb	58 seconds	230 VAC ±10%, 50/60 Hz	30%		•	•	none, opt 1k
	SY10-120MFT	2500 Nm / 22250 in-lb	58 seconds	120 VAC ±10%, 50/60 Hz	75%	•			2-10 VDC/4-20 mA
	SY10-230MFT	2500 Nm / 22250 in-lb	58 seconds	230 VAC ±10%, 50/60 Hz	75%	•			2-10 VDC/4-20 mA
SY11	SY11-110	3000 Nm / 26700 in-lb	58 seconds	120 VAC ±10%, 50/60 Hz	30%		•	•	none, opt 1k
	SY11-220	3000 Nm / 26700 in-lb	58 seconds	230 VAC ±10%, 50/60 Hz	30%		•	•	none, opt 1k
	SY11-120MFT	3000 Nm / 26700 in-lb	58 seconds	120 VAC ±10%, 50/60 Hz	75%	•			2-10 VDC/4-20 mA
	SY11-230MFT	3000 Nm / 26700 in-lb	58 seconds	230 VAC ±10%, 50/60 Hz	75%	•			2-10 VDC/4-20 mA
SY12	SY12-110	3500 Nm / 31150 in-lb	58 seconds	120 VAC ±10%, 50/60 Hz	30%		•	•	none, opt 1k
	SY12-220	3500 Nm / 31150 in-lb	58 seconds	230 VAC ±10%, 50/60 Hz	30%		•	•	none, opt 1k
	SY12-120MFT	3500 Nm / 31150 in-lb	58 seconds	120 VAC ±10%, 50/60 Hz	75%	•			2-10 VDC/4-20 mA
	SY12-230MFT	3500 Nm / 31150 in-lb	58 seconds	230 VAC ±10%, 50/60 Hz	75%	•			2-10 VDC/4-20 mA

Proportional actuators will accept 0-10 VDC, 2-10 VDC, or 4-20 mA control signals as standard.

All SY actuators are non-spring return, but can be used with NSV-SY back up systems for fail-safe applications.

These products carry a two year warranty when sold as part of an assembly or with a UFLK retrofit kit.

ROTARY ACTUATORS

SERIES	MODEL	Spring Return	Electronic Fail Safe	Control Input	Feedback Position	Power Supply
AF Series*	AF24 US, AFB24	•		24 VAC/DC		24 VAC/DC
	AFX24-MFT-X1	•		Variable with MFT (VDC, PWM, Floating Pt., On/Off)	variable VDC	24 VAC/DC
AM Series*	AMB24-3-X1			24 VAC/DC		24 VAC/DC
	AMX24-MFT-X1			Variable with MFT (VDC, PWM, Floating Pt., On/Off)	variable VDC	24 VAC/DC
GM Series*	GMB24-3-X1			24 VAC/DC		24 VAC/DC
	GMX24-MFT-X1			Variable with MFT (VDC, PWM, Floating Pt., On/Off)	variable VDC	24 VAC/DC
GK Series*	GKB24-3-X1		•	24 VAC/DC		24 VAC/DC
	GKX24-MFT-X1		•	Variable with MFT (VDC, PWM, Floating Pt., On/Off)	variable VDC	24 VAC/DC

*Please consult the Damper sections for a full list of product offerings. Standard run times should be considered in the selection. All air side products are applicable for retrofit kits.

Select "X1" actuators come with a handle.

MULTI-FUNCTION TECHNOLOGY

ROTARY ACTUATOR CODES	P-CODE		Control Input	Running Time	Built-in Feedback
	P-10001	A01	2-10 VDC	150 seconds	2-10 VDC
	P-10002	A02	0-10 VDC	150 seconds	0-10 VDC
	P-10028	A28	0-10 VDC	150 seconds	0-10 VDC
	P-10063	A63	0.5-4.5 VDC	150 seconds	0.5-4.5 VDC
	P-10064	A64	5.5-10 VDC	150 seconds	5.5-10 VDC
	P-20002	W02	0.02-5.00 seconds PWM	150 seconds	2-10 VDC
	P-20003	W03	0.10-25.5 seconds PWM	150 seconds	2-10 VDC
	P-30001	F01	Floating Pt.	150 seconds	2-10 VDC
	P-40002	J02	On/Off	150 seconds	2-10 VDC

SY MULTI-FUNCTION TECHNOLOGY

Description	MFT-CODE	Control Input	Built-in Feedback	Loss of Signal	Running Time
MFT	ACE	2...10V	2...10V	stop	actuator(s) constant
MFT	ACF	0.5...10V	0.5...10V	stop	actuator(s) constant
MFT	ACG	4...20mA	4...20mA	stop	actuator(s) constant
MFT	ACH	4...20mA	2...10V	stop	actuator(s) constant
MFT	ACJ	2...10V	2...10V	open	actuator(s) constant
MFT	ACK	0.5...10V	0.5...10V	open	actuator(s) constant
MFT	ACL	4...20mA	4...20mA	open	actuator(s) constant
MFT	ACM	4...20mA	2...10V	open	actuator(s) constant
MFT	ACN	2...10V	2...10V	close	actuator(s) constant
MFT	ACP	0.5...10V	0.5...10V	close	actuator(s) constant
MFT	ACR	4...20mA	4...20mA	close	actuator(s) constant
MFT	ACS	4...20mA	2...10V	close	actuator(s) constant

All other configurations carry a \$34.00 list price.

Standard delivery may vary, please consult your customer service representative for the latest lead time(s).

800-543-9038 USA

866-805-7089 CANADA

203-791-8396 LATIN AMERICA



LD1/WD1 Series Butterfly Valves (14" to 24" Valves Exclusively)
LD2/WD2 Series Butterfly Valves (2" to 12" Valves Exclusively)
Linkage/Actuator Selection Guide

Valve Body Model	Valve Configuration	Size	Failsafe	Close-Off psi	Belimo Actuator Series (Sold Separately)	Belimo Linkage
LD1/WD1 Series Butterfly Valves	2-way	14"	No	150	SY7	UFLK2960
		16"	No	150	SY8	UFLK2968
		18"	No	150	SY8	UFLK2962
		20"	No	150	SY9	UFLK2964
	3-way	14"	No	150	SY11	UFLK2966
		16"	No	150	SY8	UFLK5956
		18"	No	150	SY9	UFLK5958
		20"	No	150	SY10	UFLK5960
		20"	No	150	SY12	UFLK5962
		20"	No	150	GM	UFLK2900
LD2/WD2, LD3 Series Butterfly Valves	2-way	2"	No	150	SY1	UFLK2942
					SY2	UFLK2946
			Yes		2*AF	UFLK2902
					GK	UFLK2900
		2½"	No	150	GM	UFLK2908
					SY1	UFLK2944
			Yes		2*AF	UFLK2910
					GK	UFLK2908
		3"	No	150	2*GM	UFLK2910
					SY2	UFLK2948
			Yes		2*GK	UFLK2910
					2*GM	UFLK2916
		4"	No	150	SY2	UFLK2950
					2*GK	UFLK2916
			Yes		SY3	UFLK2952
					SY3	UFLK2952
	8"	No	150	SY4	UFLK2954	
				SY4	UFLK2956	
	10"	No	150	SY6	UFLK2958	
				SY6	UFLK2958	
	3-way	2"	No	150	GM	UFLK5900
					SY2	UFLK5942
			Yes		2*AF	UFLK5902
					GK	UFLK5900
		2½"	No	150	2*GM	UFLK5910
					SY2	UFLK5944
			Yes		2*GK	UFLK5910
					2*GM	UFLK5910
		3"	No	150	SY2	UFLK5944
					2*GK	UFLK5910
			Yes		SY3	UFLK5946
					SY4	UFLK5948
4"		No	150	SY4	UFLK5948	
				SY4	UFLK5948	
5"		No	150	SY6	UFLK5950	
				SY6	UFLK5952	
8"	No	150	SY8	UFLK5954		
			SY8	UFLK5954		

All close-off pressures listed are approximate and based on valve condition and application.

M40045 - 10/10 - Subject to change. © Belimo Aircontrols (USA), Inc.

**Industrial Electric 2-way
Generic – Must complete BFV Retrofit Form**

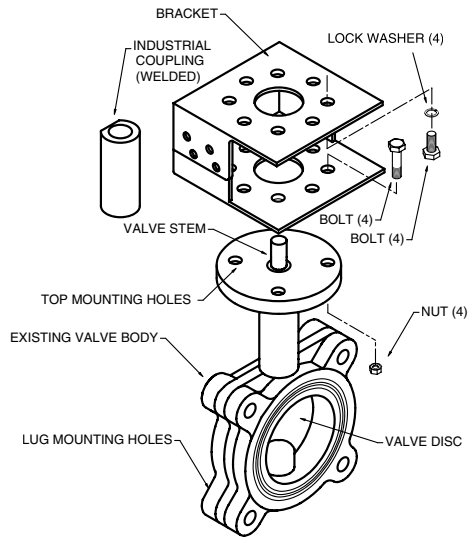

**UFSP0020
UFSP0022**

**SY1 - SY8
SY9 - SY12**

**Industrial Electric 3-way
Generic – Must complete BFV Retrofit Form**

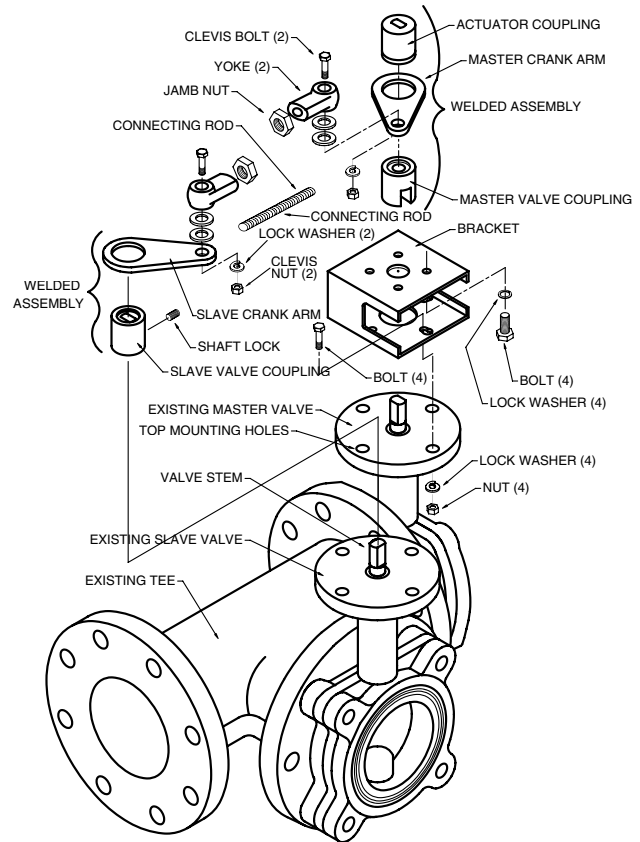

**UFSP0024
UFSP0026**

**SY1 - SY8
SY9 - SY12**

NOTE: 3-way bracket configuration shown is only one of many possible arrangements.

M40045 - 10/10 - SUBJECT TO CHANGE. © BELIMO AIRCONTROLS (USA), INC.

Assembly Procedure for SY...Retrofit Solution

Retrofit Requirement: The initial step is to determine if your application can accept a retrofit solution. As shown below (Fig. 1), the valve stem must not be located below the horizontal plane. If this condition exists, the SY actuator could not be used in this situation. A Belimo technical support person is available to help determine what solution best fits your application. A typical solution is shown in Fig. 2.

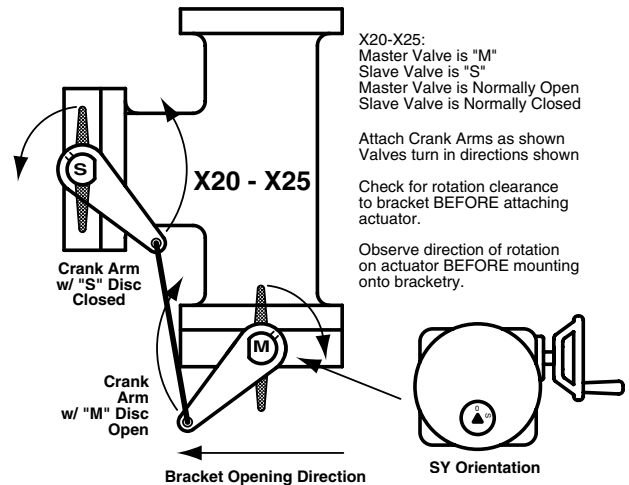
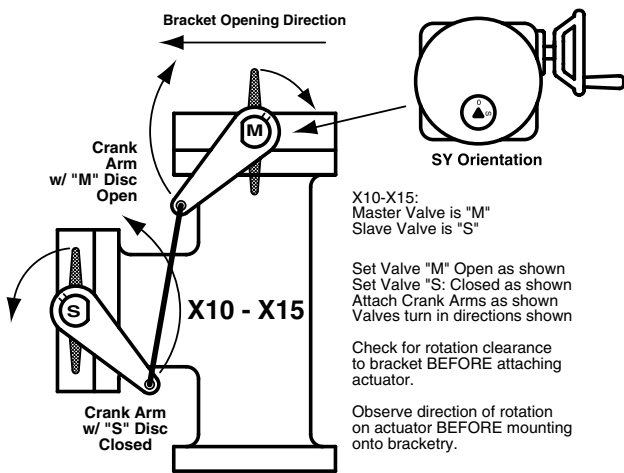
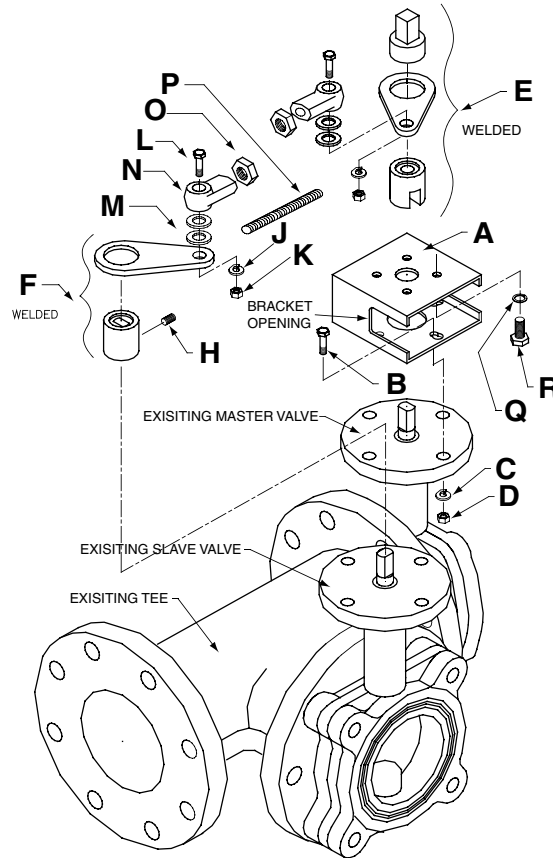
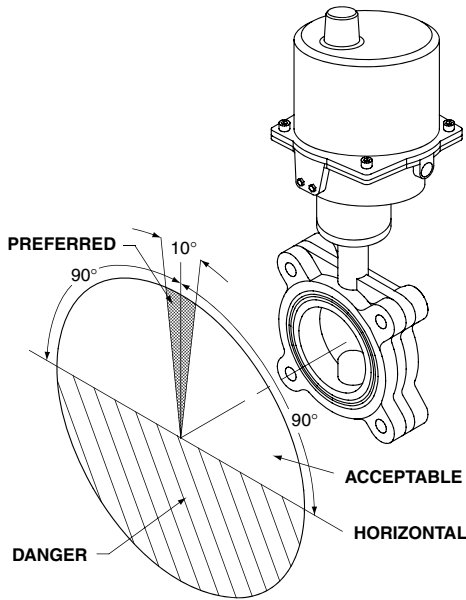

Depending on the orientation of the tee assembly, if the valves are mounted on the TOP and BRANCH positions (tee mounted vertically), or on the LEFT and BRANCH positions (tee mounted horizontally) you will refer to configuration codes X10-X15.

If the valves are mounted on the BOTTOM and BRANCH positions (tee mounted vertically), or on the RIGHT and BRANCH positions (tee mounted horizontally) you will refer to configuration codes X20-X25.

M40045 - 10/10 - SUBJECT TO CHANGE. © BELIMO AIRCONTROLS (USA), INC.

Assembly Procedure (Mechanical)

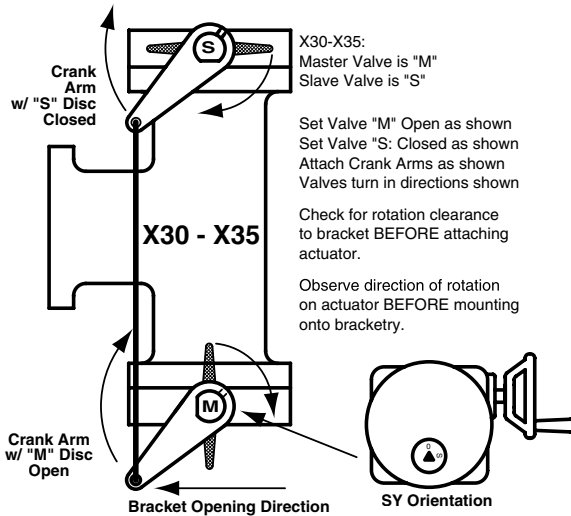

If the valves are mounted on the TOP and BOTTOM positions (tee mounted vertically), or on the LEFT and RIGHT positions (tee mounted horizontally) you will refer to configuration codes X30-X35.

Note: For purposes of clarity, this procedure utilizes configuration codes X20-X25.

During the assembly procedure, CLOSED and OPEN means 0 degrees and 90 degrees respectively. Failure to position the discs into their proper quadrants will result in improper operation and performance of the retrofit kit. Most manufacturers mark the TOP of the valve stem with a slot or other mark which indicates the disc angle. **Note:** Regardless of configuration code, the Master valve should always be OPEN and the Slave valve should always be CLOSED before starting the assembly process.

Note: Steps 3 thru 6 may be combined into a single step if the retrofit kit is received with actuator, bracket and crank arm already assembled. The actuator will be in the OPEN position for assembly.

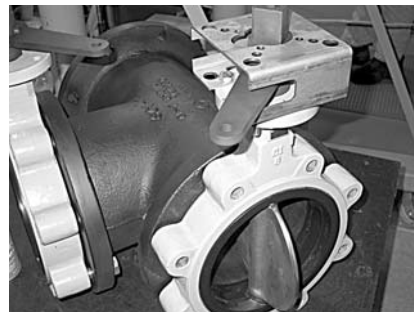

Step 3) Install the MASTER valve crank arm onto the MASTER valve in the correct orientation, as shown. Install the SLAVE valve crank arm onto the SLAVE valve in the correct orientation, as shown.



Step 1) Both valves must be stripped down to their basic form. Remove all other linkage components before starting the assembly sequence below. The linkage components have been designed to attach to the valves in their basic form state rather than to any existing hardware.

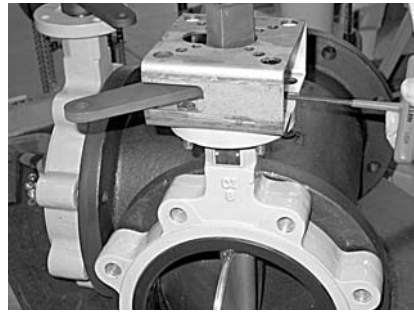

Step 4) Tighten the MASTER and SLAVE crank arm assemblies using the appropriate hex key wrench. Make sure the drive couplings are fully seated onto the valve stems BEFORE tightening the set screws.



Step 2) Referring to the three configuration types on page 3 of the SY IOM, position the master and slave valve discs as instructed. For example, if you have a configuration code X20 tee assembly, you will OPEN the Master valve (M) and CLOSE the Slave valve (S).



Step 5) Shown here is the SLAVE crank arm assembly being secured to the valve stem. Notice the markings on the valve top works indicating OPEN and CLOSED positions of the stem for later reference. Once set, crankarms may require spot

welding to the coupling on SY7-12 units.

SY... Series Butterfly Valve Retrofit Solution

Retrofitting 3-way Valves with Belimo SY Non-Spring Return Actuator

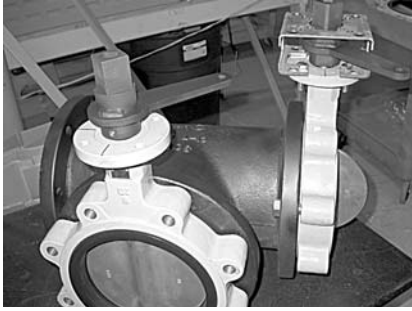

Step 6) There are no other possible orientations of this bracket. The Master crank arm will rotate 90 degrees clockwise, and there are reliefs in the sides of the bracket to accommodate this angular rotation.



Step 10) Although the SY actuator ships from the factory IN the OPEN position, make sure the actuator is in the OPEN position before attaching to the valve/coupling assembly. The SY actuator turns counter clockwise (CCW) to the OPEN position when viewed from ABOVE the actuator.



Step 7) Insert the four bolts and mount the bracket to the valve mounting flange. Attach the lock washers and nuts, but do NOT tighten at this time.

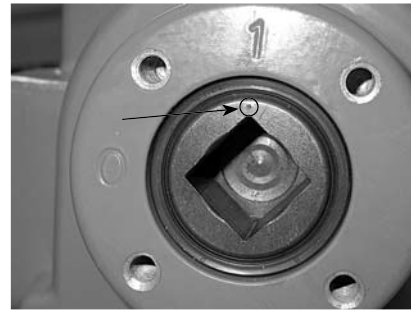

Step 11) Verify that the SY actuator is in the OPEN position also by looking at the bottom of the actuator. There is a dimple mark punched in the output shaft which will align with the "1" mark when the actuator is in the OPEN position.



Step 8) To facilitate the insertion of the mounting bolts, it may be necessary to move the valve disc, and therefore the crank arm, to gain access to the mounting holes.



Step 12) Attach the hand knob to the hand wheel as shown below (if not already completed).



Step 9) Remove the SY actuator from its protective cartons.



Step 13) Tighten the jam nut to prevent the hand knob from coming loose.



Step 14) Stand with the opening in the actuator bracket facing towards your LEFT. Hold the SY actuator with the handwheel on the RIGHT, and the EMT connectors to your LEFT. Align the square drive or keyway in the SY

actuator with the square drive or keys in the coupling (C). The SY actuator will slide completely over the drive square and will rest ON the mounting bracket (A).

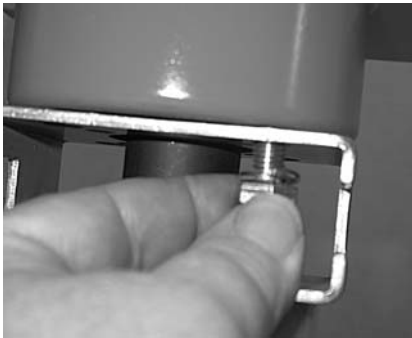

Step 15) Insert the four hex bolts (G) and lock washers (F) through the bracket and into the bottom of the SY actuator as shown. Do NOT tighten until all four sets have been installed. Slight twisting of the entire SY actuator will facilitate alignment of the bolts.



Step 16) After all four bolts have been inserted, tighten accordingly.



Step 17) Now tighten the four bracket bolts (B, C, D) assembled in step 6 above.



Step 18) When mechanical assembly is complete, the SY actuator and MASTER valve should be oriented as shown below. The actuator is in the OPEN position, and the valve disc is fully OPEN, and all bolts are tight.



Step 19) The SLAVE valve is fully CLOSED with the crank arm oriented as shown.

Note:

The assembly now must be tested electrically *before* mechanical connection is made between the MASTER and SLAVE valve crank arms. Continue with electrical assembly on page 18 for On/Off models or page 20 of the SY IOM for proportional models.

Application Note:

The hand wheel on the SY actuator is engaged at all times but does not rotate when the actuator is running. It is possible at anytime to turn the hand wheel by simply rotating it CW or CCW. The hand wheel does NOT need to be pulled or pushed into the actuator to make it operational. However, it should be noted that if a control signal and power is present at the actuator when the hand wheel is turned, the actuator will return to its controlled position. If it is desired to have the actuator maintain its position after turning the hand wheel, it will be necessary to remove power from the actuator, either at the source or by use of an optional SY-HOA local switch.

SY... Series Butterfly Valve Retrofit Solution

Retrofitting 3-way Valves with Belimo SY On/Off Non-Spring Return Actuator

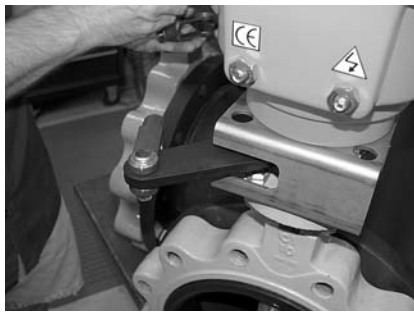

Step 20) With the MASTER valve in its fully OPEN position and the SLAVE valve in its fully CLOSED position, assemble the yoke and clevis pins onto the crank arms, pointing towards each other as shown.



Step 23) Remove the MASTER valve yoke end and thread it onto the connecting rod. Adjust the distance between the yoke centers to match the hole in the MASTER valve crank arm.



Step 21) Measure the distance between the inboard end of the yokes to determine the proper length of the connecting rod. It is important to make sure the MASTER and SLAVE valves are in their proper positions (OPEN and CLOSED, respectively) before

taking this measurement. Otherwise, the connecting rod could be too short for proper calibration of the SLAVE valve.



Step 24) Insert the clevis pin into the master crank arm.



Step 25) Using the correct control signal (On/Off or Proportional) drive the MASTER valve 25% CLOSED, then drive the MASTER valve fully OPEN. The SLAVE valve should now be fully CLOSED. The SLAVE valve should now be fully CLOSED. If the

SLAVE valve needs to be adjusted, it is accomplished by turning one of the yoke ends in (to shorten) or out (to lengthen) and rechecking the rotation angle using terminals #3 and #4 on the SY actuator. Always be sure to let the electrical travel cams stop the SY actuator before making any adjustments in the yoke ends of the connecting rod.



Step 22) After the connecting rod is cut to the correct length, screw it into SLAVE valve yoke end until the threads pass through the yoke and just start to protrude into the inboard end of the yoke. The rod lock nut should be closest to the SLAVE valve yoke end.

M40045 - 10/10 - SUBJECT TO CHANGE. © BELIMO AIRCONTROLS (USA), INC.



Step 26) Once the SLAVE valve has been determined to be in the correct position, lock the jam nut against one of the yoke ends to prevent any changes in the adjustments just completed.



Step 27) Insert two cotter keys into the two clevis pins.

Step 28) Replace the cover on the SY actuator and secure the four cover screws. One final check to make sure all bolts, screws, nuts & setscrews are tight.

Step 29) The mechanical and electrical installation of your retrofit system is now complete.

END PROCEDURE

SY... Series Butterfly Valve Retrofit Solution

Retrofitting 3-way Valves with Belimo SY On/Off Non-Spring Return Actuator



Assembly Procedure (Electrical), On/Off Models



Step 1) Remove the four hex bolts securing the cover to the base casting.



Step 6) Apply proper voltage to terminals #1 (Neutral) and #7 (Hot). Apply proper actuator voltage to terminals #1 (Neutral) and #4 (Hot) to drive the actuator CLOSED until the end-of-travel cam STOPS the actuator movement. (Note that there is no terminal #2).

Step 7) Visually check the position of the valve to make sure it reaches its full CLOSED position.



Step 2) Remove cover from the SY actuator. A flat blade screwdriver inserted carefully into the provided slot (as shown) will facilitate removal of the cover.

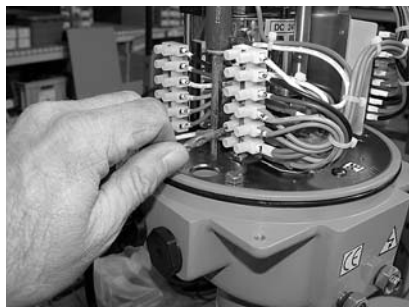

Step 8) Apply proper actuator voltage to terminals #1 (Neutral) and #3 (Hot) to drive the actuator OPEN until the end-of-travel cam STOPS the actuator movement.

Step 3) Conduit entries into the SY actuator must be selected for their operating location (indoors protected, indoors wash down, outdoors, etc). Be sure to follow standard NEC guidelines when selecting conduit and connector types.

Step 4) Follow the wire sizing chart in the Installation Operation Manual (IOM) (Belimo p/n 71150-00001.C page 10) to make sure you use the correctly size wire when connecting the SY to your power source. Failure to follow the recommendations in the table could cause actuator failure or nuisance tripping.

Step 5) Follow the wiring diagrams in the IOM (pages 18 [single] and 23 [multiple]) for proper power and control wiring to the SY actuator. Make note of the following:

- a. Do NOT connect multiple actuators in parallel without isolation relays.
- b. Be sure "Hot" is connected to terminal #7 to enable the heater circuit, and "Neutral" is connected to terminal #1.

Step 9) Visually check the position of the valve disc to make sure it reaches its full OPEN position.

Step 10) If the MASTER valve functions properly, mechanical assembly and electrical checkout are complete.



WARNING

FACTORY NOTE:

The SY actuators have been calibrated at the factory before shipping to you for use in this retrofit kit. The SY actuator calibration will suffice 99% of the time for your application. Improper calibration to the actuator may void your warranty. If you have any questions, please contact a Belimo technical support representative at 800-543-9038 for assistance.

M40045 - 10/10 - SUBJECT TO CHANGE. © BELIMO AIRCONTROLS (USA), INC.

Assembly Procedure (Electrical), Proportional Models



Step 1) Remove the four hex bolts securing the cover to the base casting.



Step 2) Remove cover from the SY actuator. A flat blade screwdriver inserted carefully into the provided slot (as shown) will facilitate removal of the cover.

Step 3) Conduit entries into the SY actuator must be selected for their operating location (indoors protected, indoors wash down, outdoors, etc). Be sure to follow standard NEC guidelines when selecting conduit and connector types.

Step 4) Follow the wire sizing chart in the Installation Operation Manual (IOM) (Belimo p/n 71150-00001.C page 10) to make sure you use the correct size wire when connecting the SY to your power source. Failure to follow the recommendations in the table could cause actuator failure or nuisance tripping.

Step 5) Follow the wiring diagrams in the IOM (pages 14-37) for proper power and control wiring to the SY actuator.

Note: All SY1-P and SY2..12-MFT actuators are factory pre-set with the proper customer requested control programming.

Step 6) Connect the proper electrical power and control wiring per the wiring diagrams located in the IOM (pages 14-37).

Step 7) Check the operation of the actuator by commanding the control system to generate control signals matching the needs of the job to run the valve from fully CLOSED to fully OPEN, as well as a MID-POINT position. The indicator on the top of the SY actuator will be an indicator as to the position of the actuator, and therefore, the valve position.

When operating the MASTER valve between fully OPEN and CLOSED, check the clearance between the crank arm and the actuator bracket. The crank arm should NEVER come into contact with the actuator mounting bracket. If it does, immediately remove power from the actuator and call Belimo technical support for recalibration instructions.

Step 8) If the valve functions properly, mechanical assembly and electrical checkout are complete.



WARNING

FACTORY NOTE:

The SY actuators have been calibrated at the factory before shipping to you for use in this retrofit kit. The SY actuator calibration will suffice 99% of the time for your application. Improper calibration to the actuator may void your warranty. If you have any questions, please contact a Belimo technical support representative at 800-543-9038 for assistance.