

MSCTA-40 & MSCTE-40 Series

Analog Output Current Sensor



Automation Components, Inc.
a DwyerOmega brand

- MSCTA-40 offers 4 to 20 mA output
MSCTE-40 offers 0 to 5 VDC output
- Split-core variant available for all MSCT current sensors
- 0 to 40 amperage sensor range
- Easy installation; DIN rail mountable

The MSCT Analog Current Sensors are designed for use in any AC current monitoring application in which you are looking to monitor a piece of equipment for proper operation.

Accuracy

With the steady decrease in operating currents on today's equipment, the MSCT Series current sensors have the industry's highest accuracy. This enables you to better monitor the current used in your applications, as well as make better maintenance decisions to ensure your systems run as efficiently as possible.

Output

The MSCTA-40 is offered in a 2 wire 4-20 mA loop powered output. The MSCTE-40 is offered in a 0-5 VDC output. The MSCT current sensors are available in a split-core version and can monitor up to 40 A.

Design

The MSCT current sensors use an "Average" current measuring method and should be used in applications where a pure Sinusoidal AC waveform that has very little or no distortion/noise on the conductor being monitored. Applications may include monitoring a resistive type load such as an incandescent light bulb or heating element as well as any single speed linear load. For best results, the MSCT current sensors should not be used in applications with switching power supplies or variable speed drives due to the limited operating frequency range.

Installation

The MSCT current sensors can be secured to the monitored cable using a cable tie and the integrated cable tie anchor feature of the housing. The MSCT also comes with an attachable mounting foot that allows the unit to be mounted in any position using one Tek screw or snapped directly on a 35 mm DIN rail.

Applications

Applications include Load Trending, Single Speed Loads, Pumps, Compressors, Fans, Preventative Maintenance, LEED, Project Justification (Calculating ROI), Process Control.

Warranty

The MSCT Current Sensors are covered by ACI's Five (5) Year Limited Warranty. The warranty can be found in the front of ACI's Sensors & Transmitters catalog, as well as on ACI's website workaci.com.



Specifications

Monitored Current Type: AC Current

Maximum AC Voltage: 600 VAC

Isolation Voltage: 2200 VAC

Operating Frequency Range: 50/60 Hz

Core Style: Split-Core

Supply Voltage (MSCTA-40):

+8.5 to 30 VDC (Reverse Polarity Protected)

250 Ohm Load (1-5 VDC): +13.5 to 30 VDC

500 Ohm Load (2-10 VDC): +18.5 to 30 VDC

Supply Current (MSCTA-40): 25 mA minimum

Supply Voltage (MSCTE-40): Induced from the Monitored Conductor (Insulated Conductors only)

Maximum Load Resistance at 24 VDC (MSCTA-40): 775 Ohms (Formula : $[24 \text{ VDC} - 8.5 \text{ VDC}] / 0.020 \text{ A}$)

Sensor Amperage Range: 40 A

Output Signal: MSCTA-40: 4 to 20 mA (2-Wire, Loop Powered)

MSCTE-40: 0-5 VDC

Response Time:

MSCTA-40: < 600 ms (Rise and Fall Times)

MSCTE-40: < 300 ms (Rise and Fall Times)

Aperture Size (Diameter) 0.20" (5.0 mm) x 0.49" (12.5 mm)

Wire Size: Fits 10 AWG to 14 AWG THHN Insulated Wire

DIN Rail Size: 35 mm

Environmental

Operating Temperature Range¹: MSCTA: -22 to 140 °F (-30 to 60 °C) MSCTE: -22 to 122 °F (-30 to 50 °C)

Operating Humidity Range: 10 to 95 %, non-condensing

Storage Temperature I Range: -40 to 158 °F (-40 to 70 °C) | 10 % to 95 % RH, non-condensing

Enclosure Material | Flammability Rating: 1PC/ABS (Polycarbonate/ABS Blend) | UL94-V0

Wiring Connections: 2 Position Screw Terminal Block (Polarity Sensitive)

Wire Size: 16 to 22 AWG (1.31 mm² to 0.33 mm²) Copper Wires Only

Terminal Block Torque Rating: 4.43 to 5.31 in-lbs. (0.5 to 0.6 Nm)

Minimum Mounting Distance: 1" (2.6 cm) between current switch & other magnetic devices (Relays, Contactors, Transformers)



Mechanical

Dimensions: 1.93" (48.99 mm) x 1.31" (33.17 mm) x 2.18" (55.37 mm)

Weight: 0.165 lbs. (0.075 Kg)

1. Maximum 40 °C for 50 Hz operation of MSCTE

Certification

UL/CUL US Listed (UL 508) Ind. Control Equipment (File # E309723), CE, RoHS, UKCA, FCC, CAN ICES-3 / NMB-3



Accuracy Specifications

	Accuracy	Current	Operating Temperature	Frequency
MSCTA-40	±0.75 % FS (±0.3 A)	Greater than 2 A	5 to 140 °F (-15 to 60 °C)	60 Hz
	±0.75 % FS (±0.3 A)	Greater than 2 A	32 to 140 °F (0 to 60 °C)	50 Hz
MSCTE-40	±0.4 % FS (±0.16 A)	Full Range	5 to 95 °F (-15 to 35 °C)	60 Hz
	±0.75 % FS (±0.3 A)	Full Range	-22 to 122 °F (-30 to 50 °C)	60 Hz
	±0.75 % FS (±0.3 A)	Full Range	-22 to 86 °F (-30 to 30 °C)	50 Hz

Dimensional Drawing

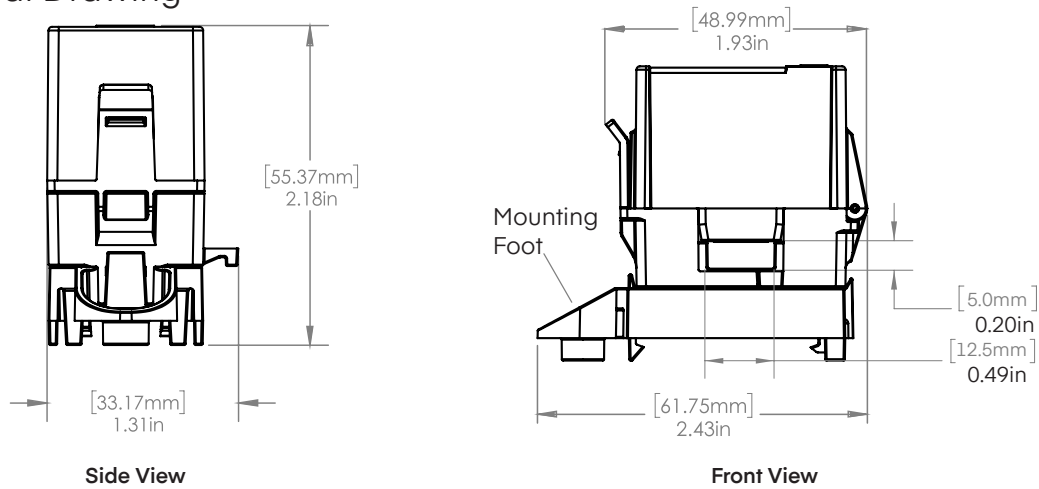

Standard Ordering

Model Number	Description	AMP Range	Output Signal
MSCTA-40	151890	0-40 A	4 to 20 mA
MSCTE-40	151889	0-40 A	0 to 5 VDC

The MSCT Current Sensors are not intended to be used in Life / Safety Applications or in Hazardous / Classified locations (environments).

Accessories Ordering

Item Number	Description
100307	249 Ohm, 1/4 W, ±1 % Tolerance, 50 PPM Resistor (Only Needed to Convert to 1-5 VDC)
100306	249 Ohm, 1/4 W, ±0.1 % Tolerance, 50 PPM Resistor (Recommended for Best Accuracy) (Only Needed to Convert to 1-5 VDC)
100469	499 Ohm, 1 W, ±1 % Tolerance, 50 PPM Resistor (Only Needed to Convert to 2-10 VDC)

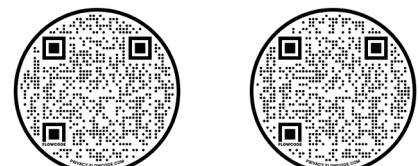

MSCTA-40

MSCTE-40