



Functional Devices, Inc.
 310 South Union Street
 Russiaville, IN 46979
 www.FunctionalDevices.com

Office 765.883.5538
 Sales 800.888.5538
 Fax 765.883.7505
 Email sales@FunctionalDevices.com



Enclosure

MH1000 Series

Metal Housing, NEMA 1, 14.50" H x 7.70" W x 3.90" D

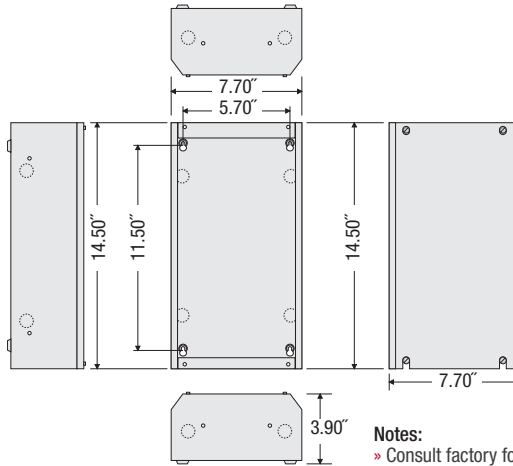

Notes:
 » Consult factory for custom colors

SPECIFICATIONS

Construction: 18 Gauge Steel
 Weight: 5.40 lbs.
 Cover Type: Screw Down Cover
 Approvals: UL Listed, C-UL, CE Approved, RoHS

MH1000 Series Assemblies

MODEL #	ENCLOSURE	MOUNTING TRACK
MH1000	MH1000	
MH1010	MH1000	MT4-12
MH1020	MH1000	MT212-12

Notes