



M9104-AGP-2S Series Electric Non-Spring Return Actuator with Pressure Sensor for VAV Applications

Installation Instructions

Part No. 34-636-2383, Rev. B
Issued March 2016

Refer to the [QuickLIT website](#) for the most up-to-date version of this document.

Applications

The M9104-AGP-2S Series Actuators are direct-mount, non-spring return electric actuators that operate on 24 VAC power and use plenum cables for field wiring. Employing a synchronous motor, these actuators provide floating control and feature an integral differential pressure sensor.

All models are compact in size and are easily installed on VAV boxes with a round shaft up to 1/2 in. (13 mm) in diameter, or a 3/8 in. (10 mm) square shaft.

The M9104 Series Electric Non-Spring Return Actuators provide a running torque of 35 lb-in (4 N-m), and the nominal travel time is 60 seconds at 60 Hz (72 seconds at 50 Hz) for 90° of rotation.

IMPORTANT: Use this M9104-AGP-2S Series Actuator only to control equipment under normal operating conditions. Where failure or malfunction of the electric actuator could lead to personal injury or property damage to the controlled equipment or other property, additional precautions must be designed into the control system. Incorporate and maintain other devices, such as supervisory or alarm systems or safety or limit controls, intended to warn of or protect against failure or malfunction of the electric actuator.

IMPORTANT: Utiliser ce M9104-AGP-2S Series Actuator uniquement pour commander des équipements dans des conditions normales de fonctionnement. Lorsqu'une défaillance ou un dysfonctionnement du electric actuator risque de provoquer des blessures ou d'endommager l'équipement contrôlé ou un autre équipement, la conception du système de contrôle doit intégrer des dispositifs de protection supplémentaires. Veiller dans ce cas à intégrer de façon permanente d'autres dispositifs, tels que des systèmes de supervision ou d'alarme, ou des dispositifs de sécurité ou de limitation, ayant une fonction d'avertissement ou de protection en cas de défaillance ou de dysfonctionnement du electric actuator.

Installation

The M9104 Series Electric Non-Spring Return Actuators mount directly to the surface in any convenient orientation using a single No. 10 self-drilling sheet metal screw (included with the actuator). No additional linkages or couplers are required. Electrical and air connections on the actuator are clearly labeled to simplify installation.

IMPORTANT: Do not install or use this M9104 Series Electric Non-Spring Return Actuator in or near environments where corrosive substances or vapors could be present. Exposure of the electric actuator to corrosive environments may damage the internal components of the device, and will void the warranty.

Parts Included

- one electric non-spring return actuator with two integrated 10 ft (3.0 m) long cables
- one No. 10 self-drilling sheet metal screw

Special Tools Needed

- 5/16 in. (8 mm) square socket or
- 3/8 in. (10 mm) 12-point socket
- drill with a 5/16 in. (8 mm) hex nut driver
- digital voltmeter or M9000-200 Commissioning Tool

Accessories

Table 1: Accessories (Order Separately)

Code Number	Description
M9000-200	Commissioning Tool That Provides a Control Signal to Drive 24 V On/Off, Floating, Proportional, and/or Resistive Electric Actuators

Mounting

To mount the actuator to a damper:

1. Check that the damper blade is visually accessible, or its position is permanently marked on the end of the damper shaft, as illustrated in Figure 2.

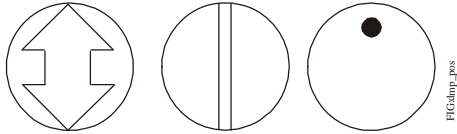

Figure 1: Damper Position Icons

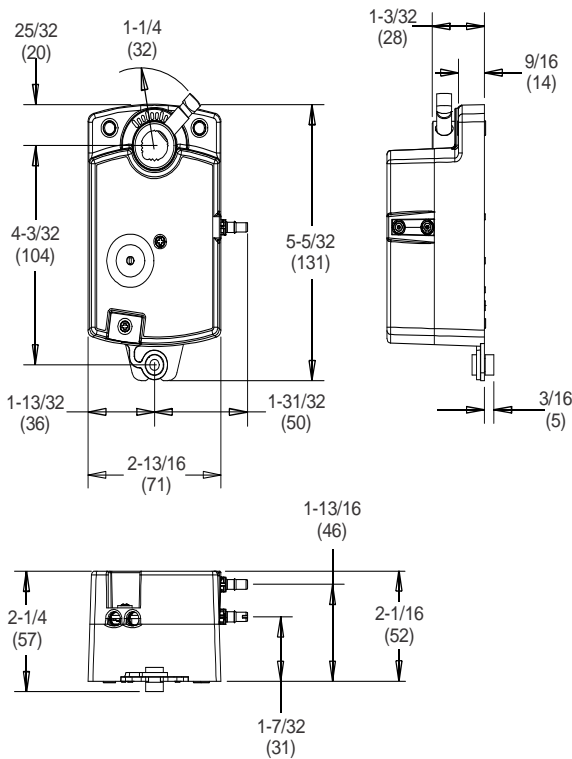

Figure 2: M9104 Series Electric Non-Spring Return Actuator Dimensions, in. (mm)

2. Grasp the damper shaft firmly with pliers and rotate the damper fully closed, as illustrated in Figure 3.

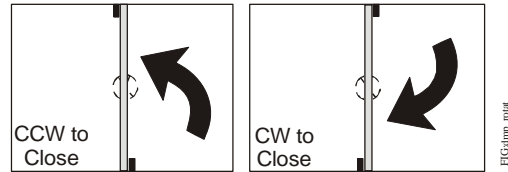
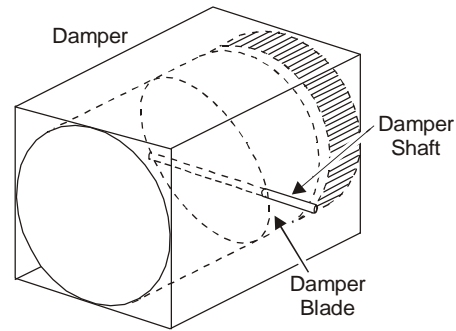

Figure 3: Damper Rotation

3. Make a note of the rotation range and direction, either clockwise (CW) or counterclockwise (CCW), required to close the damper.
4. Press and hold the gear release lever, and rotate the actuator coupler to the fully closed position, as determined in Step 2.
5. Position the actuator onto the damper shaft so that the damper shaft protrudes through the actuator coupler, as illustrated in Figure 4.

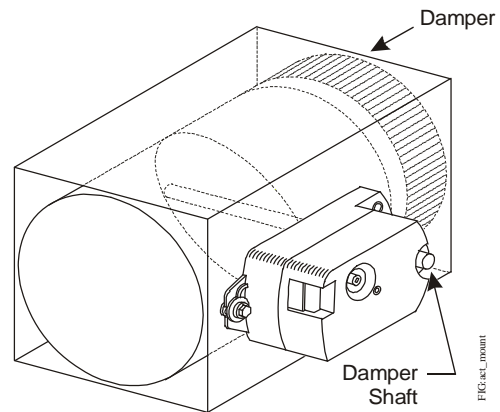

Figure 4: Mounting the Actuator onto the Damper Shaft

6. Be certain that the actuator is in the desired mounting position parallel to the mounting surface, as illustrated in Figure 5.

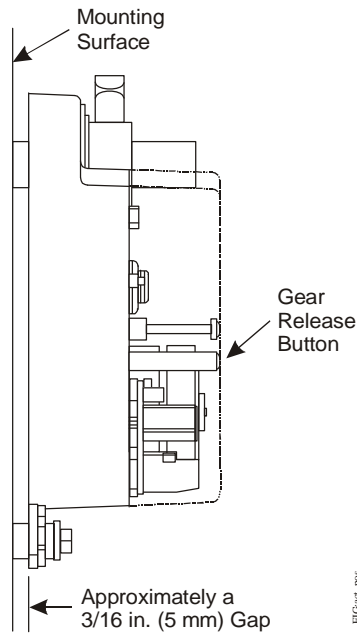

Figure 5: Positioning the Actuator

7. Hold the actuator in place on the damper shaft, and insert the No. 10 self-drilling sheet metal screw through the shoulder washer, as illustrated in Figure 6.

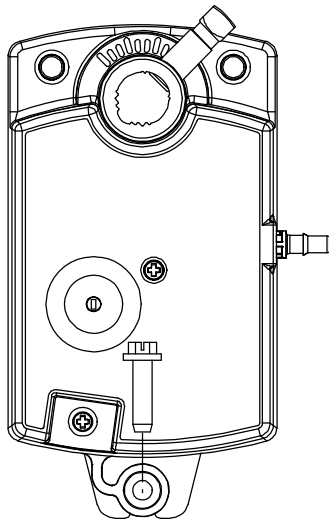

Figure 6: Inserting the Screw into the Shoulder Washer

IMPORTANT: When the air supply to the VAV box is below 50°F (10°C), make sure that any condensation on the VAV box, particularly on the damper shaft, does not enter the M9104 electronics. Mount the actuator vertically above the damper shaft to allow any shaft condensation to fall away from the M9104. Additional measures may be required in some installations.

8. Place a 5/16 in. (8 mm) socket on the screw and use a drill and extension to drill the screw into the mounting surface. Drive the screw until it is tight against the washer.

IMPORTANT: Do not overtighten the mounting screw. Overtightening may strip the threads.

9. Tighten the square coupler bolt to the shaft using an 5/16 in. (8 mm) wrench or 3/8 in. (10 mm) 12-point socket. Tighten to 95 to 105 lb-in (10.5 to 11.5 N·m).

Differential Pressure Sensor

Use the integrated actuator fittings to connect the differential pressure sensor to the flow pickup device provided with the VAV box. To connect:

1. Cut two lengths of tubing and connect them to the flow pickup device.

IMPORTANT: Ensure the tubing is properly sized and composed of elastic material, such as silicone rubber, to minimize flow measurement errors and create an airtight connection.

2. Connect the tubing from the flow pickup device to the barbed fitting on the actuator (Figure 7).

Note: The pressure sensor self-detects high and low pressure.
3. Loop the pneumatic tubing to include a trap for condensation. This prevents any condensation from entering the sensor by creating a trap. Do not bend the tubing.

IMPORTANT: Do not blow into the ports to test the operation. This may damage the sensing element. Overpressure limit is 150 in. W.C. (37.36 kPa).

Wiring

M9104-AGP-2S

The M9104 Series Electric Non-Spring Return Actuators require an AC 24 VAC input signal and are compatible with a variety of VAV controls. These electric actuators include two integrated 10 ft (3.6 m) cables. See Figure 8 for proper wiring..

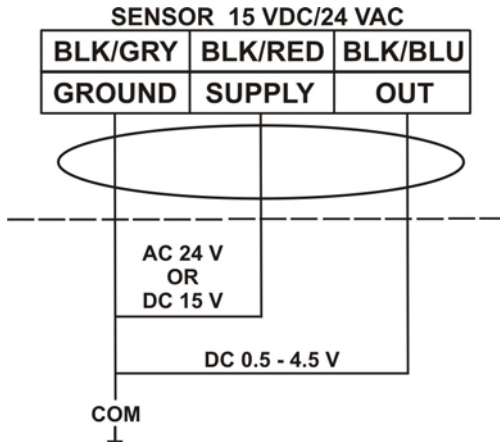

Figure 7: Connecting the Differential Pressure Sensor

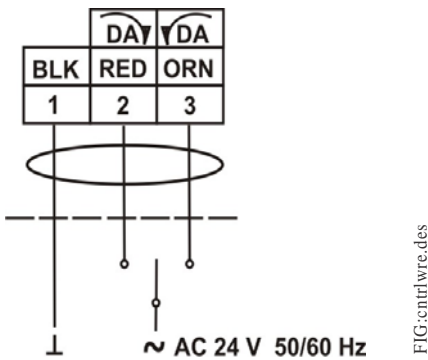

Figure 8: M9104-AGP-2S Control Wiring Diagram

Note: When using an AGP model, you must use a VAV controller or software that provides a time out function at the end of rotation (stall) to avoid excessive



CAUTION: Risk of Property Damage.

Do not apply power to the system before checking all wiring connections. Short circuited or improperly connected wires may result in permanent damage to the equipment.

MISE EN GARDE : Risque de dégâts matériels.

Ne pas mettre le système sous tension avant d'avoir vérifié tous les raccords de câblage. Des fils formant un court-circuit ou connectés de façon incorrecte risquent d'endommager irrémédiablement l'équipement.

IMPORTANT: Make all wiring connections in accordance with local, national, and regional regulations. Do not exceed the electrical ratings of the M9104 Series Electric Non-Spring Return Actuator.

Setup and Adjustments

Commissioning

After wiring is completed, apply power to the VAV controller and provide input signals to the actuator to drive it at least one complete cycle open and closed.

Troubleshooting

If the M9104 Series Electric Non-Spring Return Actuator is not responding or working properly:

- verify that the actuator assembly is properly secured to the duct
- check that all electrical connections are complete and that power is applied
- verify that the damper fully opens and closes, using the gear release button on the actuator
- check that the actuator stroke is set for the desired application

Differential Pressure Sensor

If the differential pressure sensor is not operating properly:

- verify that the air lines on the differential pressure sensor are connected with no kinks in the tubing
- check the supply voltage to ensure it is within the 14.5 to 17 VDC or 24 VAC +/-20% range and the polarity is accurate
- disconnect the air lines from both ports and place a voltmeter across the OUT and GND terminals. If the output is not between 0.4 and 0.6 volts with power applied to the differential pressure sensor, the M9104-AGP-2S is defective and should be replaced.

Note: Voltage readings may vary by 0.1 volt if the transmitter is in a horizontal position.

Repair Information

If the M9104 Series Electric Non-Spring Return Actuator fails to operate within its specifications, replace the unit. For a replacement electric actuator, contact the nearest Johnson Controls representative.

The differential pressure sensor is not repairable or replaceable. Complete assembly replacement is required if something is wrong with the differential pressure sensor.

Technical Specifications

M9104-AGP-2S Series Electric Non-Spring Return Actuator (Part 1 of 2)

Power Requirements	M9104-AGP-2S	20 to 30 VAC at 50/60 Hz, 2.1 VA Supply, Class 2
	Differential Pressure Sensor	15 VDC (14.5 to 17 VDC) unregulated; 15 mA maximum or 24 VAC +/- 20%
Control Signal		24 VAC (20 to 30) at 50/60 Hz
Control Input Impedance		200 ohms, nominal
Differential Pressure Sensor	Pressure Range	0 to 1.5 W.C. (0 to 374 Pa)
	Over Pressure Limit	150 in. W.C. (37.36 kPa)
	Output Voltage	0.5 to 4.5 VDC with 25,000 ohm minimum load impedance
	Total Error Band	1.3% FS (Combined error from calibration, accuracy, and temperature effects)
	Accuracy at 77°F (25°C)	0.25% FS Accuracy (Includes non-linearity, hysteresis, and non-repeatability)
	Long-Term Stability	0.5% FS
Running Torque		35 lb·in (4 N·m)
Rotation Range		0 to 90°, CW or CCW
Rotation Time		Nominal 60 seconds at 60 Hz for 90° Nominal 72 seconds at 50 Hz for 90°
Cycles		100,000 Full Stroke Cycles; 2,500,000 Repositions at Rated Running Torque, 35 lb·in (4 N·m)
Audible Noise Rating		35 dBA maximum at 1 m
Enclosure		NEMA 1, IP42
Ambient Conditions	Operating	32 to 122°F (0 to 50°C); 90% RH maximum, noncondensing
	Storage	-20 to 150°F (-29 to 66°C); 90% RH maximum, noncondensing
Dimensions (H x W x D)		5.67 x 2.80 x 2.24 in. (144 x 71 x 57mm)

M9104-AGP-2S Series Electric Non-Spring Return Actuator (Part 2 of 2)

	United States	UL Listed, to UL 60730-1A: 2009-10-19, Ed. 4.0, Automatic Electrical Controls for Household and Similar Use; and UL 60730-2-14: 2013-02-27, Ed. 2, Part 2 Particular Requirements for Electric Actuators Plenum Rated (UL 2043). Suitable for use in Other Environmental Air Space (Plenums) in accordance with section 300.22 (C) of the National Electric Code
	Canada	UL Listed, CCN XAPX7, File E27734; to UL 60730-1:02-CAN/CSA: July 2002, 3rd Ed., Automatic Electrical Controls for Household and Similar Use; and CSA C22.2 No. 24-93 Temperature Indicating and Regulating Equipment Actuator Housing is Plenum Rated per CSA C22.2 No. 236/UL 1995, Heating and Cooling Equipment
	Europe	IEC 60730-1: Automatic Electrical Controls for Household and Similar Use, Part 1: General Requirements: 2010-03, Edition 4; IEC 60730-1-14, Automatic Electrical Controls for Household and Similar Use; Part 2: Particular Requirements for Electric Actuators CE Mark – Johnson Controls, Inc. declares that this product is in compliance with the essential requirements and other relevant provisions of the EMC Directive and the Low Voltage Directive.
	Australia and New Zealand	RCM Mark, Australia/NZ Emissions Compliant
Shipping Weight		1.0 lb (0.45 kg)

The performance specifications are nominal and conform to acceptable industry standards. For application at conditions beyond these specifications, consult the local Johnson Controls office. Johnson Controls, Inc. shall not be liable for damages resulting from misapplication or misuse of its products.

European Single Point of Contact:

JOHNSON CONTROLS
WESTENDHOF 3
45143 ESSEN
GERMANY

NA/SA Single Point of Contact:

JOHNSON CONTROLS
507 E MICHIGAN ST
MILWAUKEE WI 53202
USA

APAC Single Point of Contact:

JOHNSON CONTROLS
C/O CONTROLS PRODUCT MANAGEMENT
NO. 22 BLOCK D NEW DISTRICT
WUXI JIANGSU PROVINCE 214142
CHINA



Building Efficiency

507 E. Michigan Street, Milwaukee, WI 53202

Metasys® and Johnson Controls® are registered trademarks of Johnson Controls, Inc. All other marks herein are the marks of their respective owners. © 2016 Johnson Controls, Inc.