

### Application

AV-607-1 and AV-609-1<sup>1</sup> linkages are designed to connect single or dual Schneider Electric spring return and non-spring return SmartX Actuators to 1-1/2" to 6" VB-9xxx and 2-1/2" to 6" VB-8xx3 globe valves.

### Features

- Allows mounting of single or dual Schneider Electric SmartX Actuators
- AV-607-1 is compatible with Schneider Electric (Siebe, Barber-Colman, INVENSYS) 2-1/2" to 5" VB-8xx3, 1-1/2" to 4" VB-931x, and discontinued 1-1/2" to 4" VB-92xx valves and Schneider Electric SmartX actuators<sup>2</sup>
- AV-609-1 is compatible with Schneider Electric (Siebe, Barber-Colman, INVENSYS) 6" VB-8xx3, 5" and 6" VB-931x, and discontinued 5" and 6" VB-92xx valves and Schneider Electric SmartX Actuators<sup>2</sup>
- Maintenance-free construction
- Corrosion protected heavy-duty steel rack and pinion construction and metal housing
- Precision rack self aligns with the valve stem

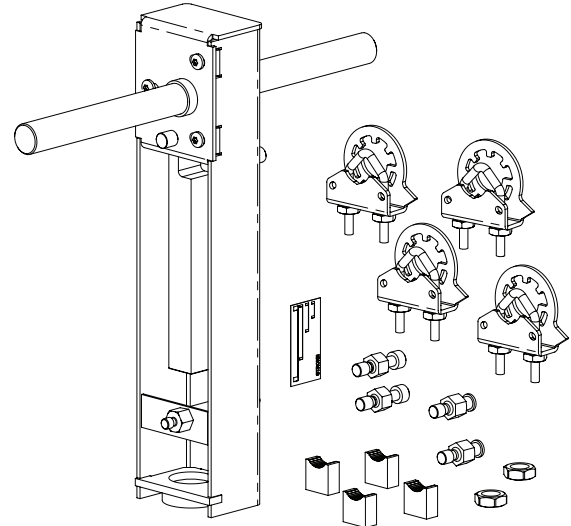

AV-607-1

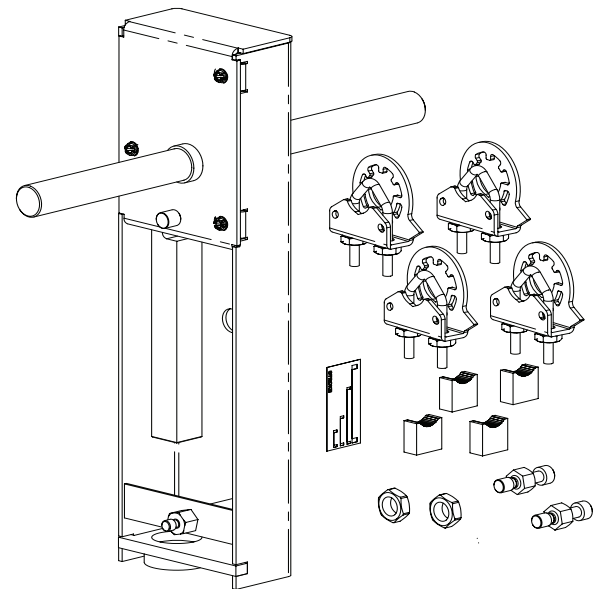

AV-609-1

<sup>1</sup>AV-607-1 and AV-609-1 replace AV-607 and AV-609 respectively

<sup>2</sup>Check the appropriate valve selection guide for close-offs for your application,

**Note:** Do not install a 300 lb-in MX41-634-x actuator on the AV-607-1 linkage as equipment damage may occur.

## Applicable Literature

- EN-205 Water System Guidelines, F-26080
- AV-608 Linkage Adapter Kit General Instructions, F-27253
- MA40-704x, MA4x-707x, MA4x-715x Schneider Electric SmartX Spring Return Two-Position Actuators General Instructions, F-26642
- MA40-717x Schneider Electric SmartX Series Spring Return Two-Position Actuators General Instructions, F-26742
- MF4x-7xx3 Schneider Electric SmartX Series Spring Return Floating Actuator General Instructions, F-26644
- MF40-7173 Schneider Electric SmartX Series Spring Return Floating Actuator General Instructions, F-26749
- MF41-6153./MS41-6153 Series Non-Spring Return Rotary Electronic Damper Actuator General Instructions, F-27215
- MS4x-7xx3 Schneider Electric SmartX Series Spring Return Proportional Actuator General Instructions, F-26645
- MS40-717x Schneider Electric SmartX Series Spring Return Proportional Actuator General Instructions, F-26748
- Mx41-6xxx-220/-230 and MX4x-7xxx-220/-230 Actuator/Linkage Assemblies for 2-1/2" to 6" Globe Valves General Instructions, F-27160
- Vx-7000 Series and Vx-9000 Series Mx4x-6xxx and Mx4x-7xxx Series Linked Globe Valve Assemblies with Schneider Electric SmartX Actuators Selection Guide, F-26752
- VB-8xx3 Series Balanced Plug Valve Selection Guide, F-27199

## Accessories

- PKG-1171 Replacement Hardware kit (to replace lost hardware; see Figure-1)

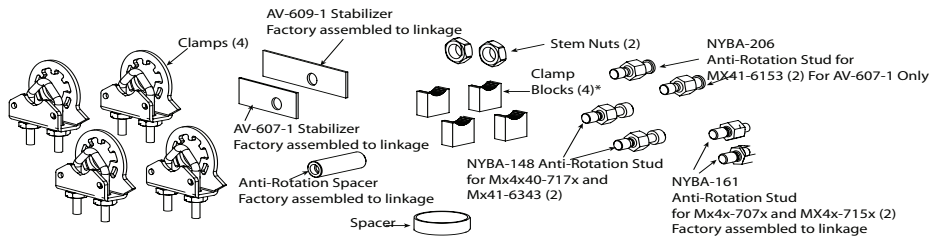

\* Clamp blocks are only required for the MX41-634x and Mx40-717x actuators.

Figure-1 Replacement Hardware

## Inspection

Inspect package for damage. If damaged, notify carrier immediately. If undamaged, open the package and inspect for obvious damage. Return damaged products.

Inspect the hardware package included with the linkage to make sure all required clamps (4), clamp blocks (4), stem lock nuts (2), and anti-rotation studs (six, two factory assembled to linkage) are included. See Figure-1. Not all parts will be needed for every installation.

## Requirements

- Training: Installer must be a qualified, experienced technician.
- Tools (not provided):
  - Appropriate wrenches for anti-rotation studs, stem extensions, packing nuts, and bracket nuts
  - 10 mm socket wrench (for shaft clamp nuts on Mx40-717x, Mx41-707x, Mx41-715x)
  - 1/2" nut driver and 1/2" open end wrench (for all except Mx41-634x, Mx40-717x)
  - Measuring scale graduated in 1/32" increments
  - Torque wrench, range to include 90 to 120 lb-in. (7.5 to 10 lb-ft, 10 to 14 N-m)
  - Pipe wrenches, two
  - 11/16" open-end wrench for jam nuts, two
  - Vise grip or pliers
  - Appropriate power supply (see the applicable actuator General Instructions sheet for power requirements)

**Warning: Electrical shock hazard! Contact with live circuits can result in severe injury or death.**



- Disconnect the power supply (line power) at the breaker or fuse before and during installation to prevent electric shock and equipment damage.

- Make all connections in accordance with the wiring diagram and in accordance with national and local electrical codes. Use copper conductors only.

Failure to observe these warnings can result in severe injury or death and can damage the equipment.

## General Installation

Schneider Electric globe valve rack and pinion linkages are provided as complete assemblies. The following pages contain instructions for installing the AV-607-1 and AV-609-1 linkages. Either a single actuator or dual actuators may be installed using these instructions.

**Note:** When installing dual actuators:

- Both actuators must be the same model.
- Actuators must be mounted and adjusted so as to rotate and spring return (if applicable) in the same direction. Refer to the mounting instructions and Table- through Table-x.
- Refer to the applicable actuator literature for actuator wiring information.
- Only use the actuator and linkage combinations that are shown on Table 1. Linkage or valve damage could result if a incorrect combination is applied.
- Do not attempt to use the actuator manual override feature with two actuators clamped to the same shaft. Damage and improper operation can occur. Using manual override to set individual actuator preload before installation on the linkage is permissible.

## Mounting Actuator and Linkage to Valve Body

### Process Overview

This mounting procedure consists of two sections:

- Section A. Mounting Linkage to Valve
  - A1. Select and install anti-rotation studs.
  - A2. VB-9xxx and VB-8xx3 (2-way and 3-way) valves and appropriate actuator types, follow the instructions in this section to assemble the linkage to the valve
- Section B. Actuator Mounting and Setup

In this section, choose the subsection that is appropriate for the specific actuator type and valve type, to mount the actuator and adjust the linkage:

- B1. Spring Return Actuators with Manual Override 2-Way Valves and 3-Way Valves (Normal Position — Valve Stem Up)
- B2. Spring Return Actuators with Manual Override 2-Way Valves and 3-Way Valves (Normal Position — Valve Stem Down)
- B3. Non-Spring Return Actuator with Manual Override VB-8213 and VB-921x 2-Way Valves (Valve Stem Up, Open) VB-8223 and VB-922x 2-Way Valves (Valve Stem Up, Closed) VB-8303 and VB-931x 3-Way Valves (Valve Stem Up, Port A Closed)
- B4. Spring Return Actuators without Manual Override VB-8223, VB-922x 2-Way Valves (Normal Position — Valve Stem Up, Closed) VB-8303, VB-931x 3-Way Valves (Normal Position — Valve Stem Up, Port A Closed)
- B5. Spring-Return Actuators without Manual Override VB-8213, VB-921x 2-Way Valves (Normal Position — Valve Stem Down, Closed) VB-8303, VB-931x 3-Way Valves (Normal Position — Valve Stem Down, Port B Closed)

The linkage is assembled to the valve according to Section A. Refer to Table-1, below, to determine the remainder of the assembly path for a specific actuator and valve.

Table-1 Procedure for Mounting Actuator and Linkage to Valve Body.

Actuator Type	Valve Type	Section B				
		Subsection B1	Subsection B2	Subsection B3	Subsection B4	Subsection B5
Spring Return Actuators with Manual Override Mx41-707x Mx41-715x	2-Way and 3-Way, Normal Position Valve Stem Up	X				
	2-Way and 3-Way, Normal Position Valve Stem Down		X			
Non-Spring Return Actuators with Manual Override Mx41-6153 Mx41-634x	2-Way and 3-Way, Normal Position Valve Stem Up			X		
	2-Way and 3-Way, Normal Position Valve Stem Down			X		
Spring Return Actuators without Manual Override Mx40-717x	2-Way and 3-Way, Normal Position Valve Stem Up				X	
	2-Way and 3-Way, Normal Position Valve Stem Down <sup>a</sup>					X

## Section A. Mounting Linkage to Valve

### A1. Select and Install Anti-Rotation Studs.

Based on the actuator(s) being used, select the appropriate anti-rotation studs using Figure-.

Two NYBA-161 anti-rotation studs (for Mx4x-707x and Mx4x-715x actuators) are shipped factory assembled to each side of the linkage. If NYBA-148 or NYBA-206 are required, remove the two factory-installed anti-rotation studs one at a time and replace them with the required studs. Hand tighten the stud in the linkage frame slot and slide down to provide clearance for actuator installation (see Figure-2 below).

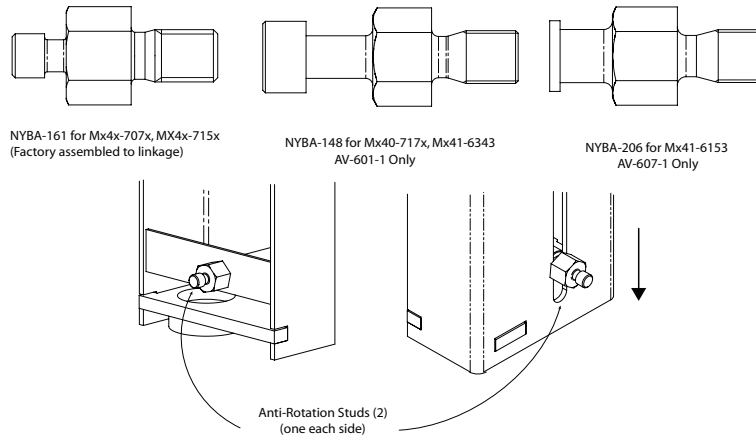

Figure-2 Anti-Rotation Studs

### A2. Mounting Linkage to Valve — VB-9xxx, VB-8xxx, and Appropriate<sup>1</sup> Actuator Models

1. Assemble the linkage to the valve, according to Figure-3.

2. Continue the assembly process according to the following section, “Section B. Actuator Mounting and Setup.”

<sup>1</sup>See Table-1 on page 3

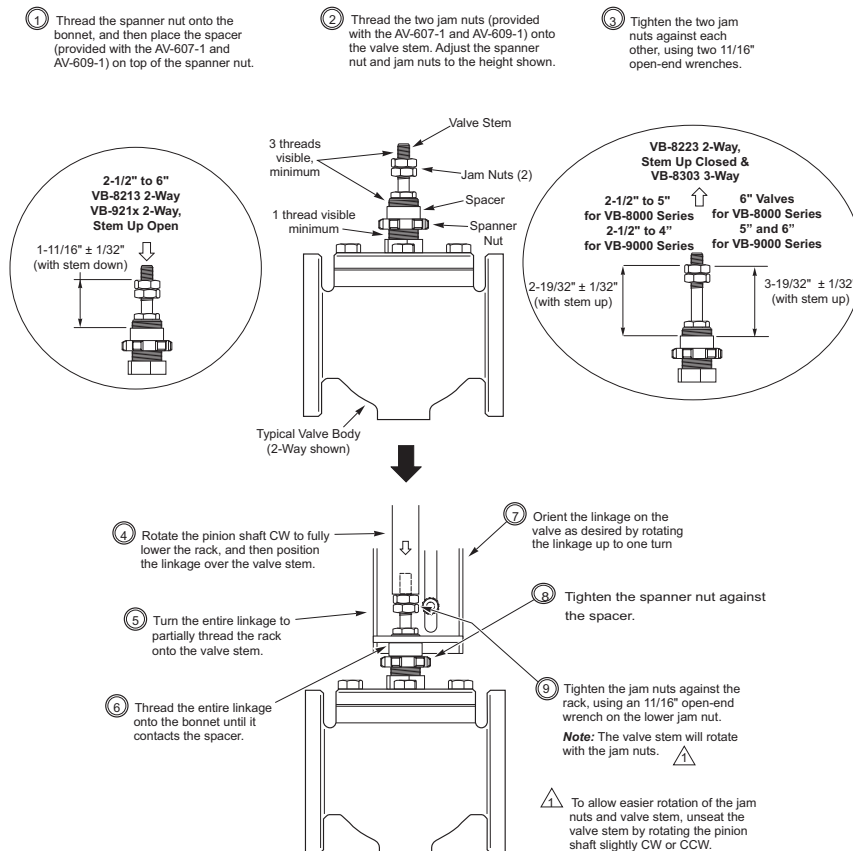

Figure-3 Assembling Linkage to Valve

## Section B. Actuator Mounting and Setup

To mount the actuator and set up the assembly, refer to the subsection that applies to the specific actuator type and valve type.

### B1. Spring Return Actuators with Manual Override 2-Way Valves and 3-Way Valves (Normal Position — Valve Stem Up)

Mx41-707x (VB-9xxx only with AV-607-1) and Mx41-715x (AV-607-1 and AV-609-1)

- a. Install the actuator (or actuators if using dual actuators) onto the linkage and valve, and set up the assembly, according to Table-3 on page 10 or Table-3 on page 11

**Note:** If using dual actuators, make sure both rotate and spring return in the same direction. Do not use manual override on installed actuators if using dual actuators. See “General Installation” on page 3.

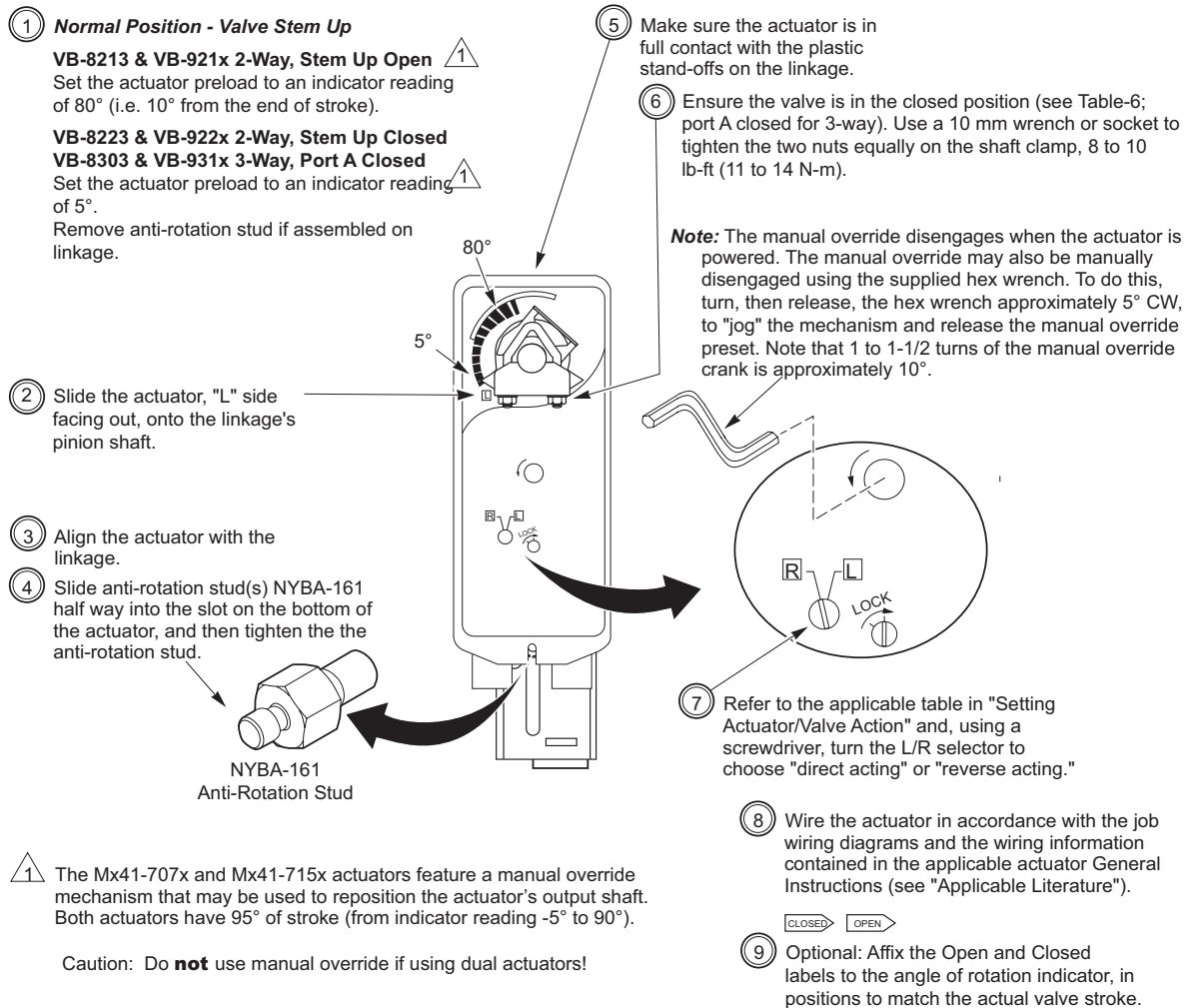

Figure-4 Mounting Mx41-707x or Mx41-715x and Setting Up Actuator/Linkage/Valve

b. Refer to the appropriate actuator General Instructions sheet for actuator wiring and application information (see “Applicable Literature” on page 2). For valve body installation and application information, refer to the appropriate valve body General Instructions sheet.

c. Power the actuator(s) and check the system’s operation for heating or cooling output, in response to the control signal. See “Setting Actuator/Valve Action” on page 10.

Mx41-707x (VB-9xxx only with AV-607-1) and Mx41-715x (AV-607-1 and AV-609-1)

- a. Install the actuator (or actuators if using dual actuators) onto the linkage and valve, and set up the assembly, according to Table-2 on page 10 or Table-3 on page 11.

**Note:** If using dual actuators, make sure both rotate and spring return in the same direction. Do not use manual override on installed actuators if using dual actuators. See “General Installation” on page 3.

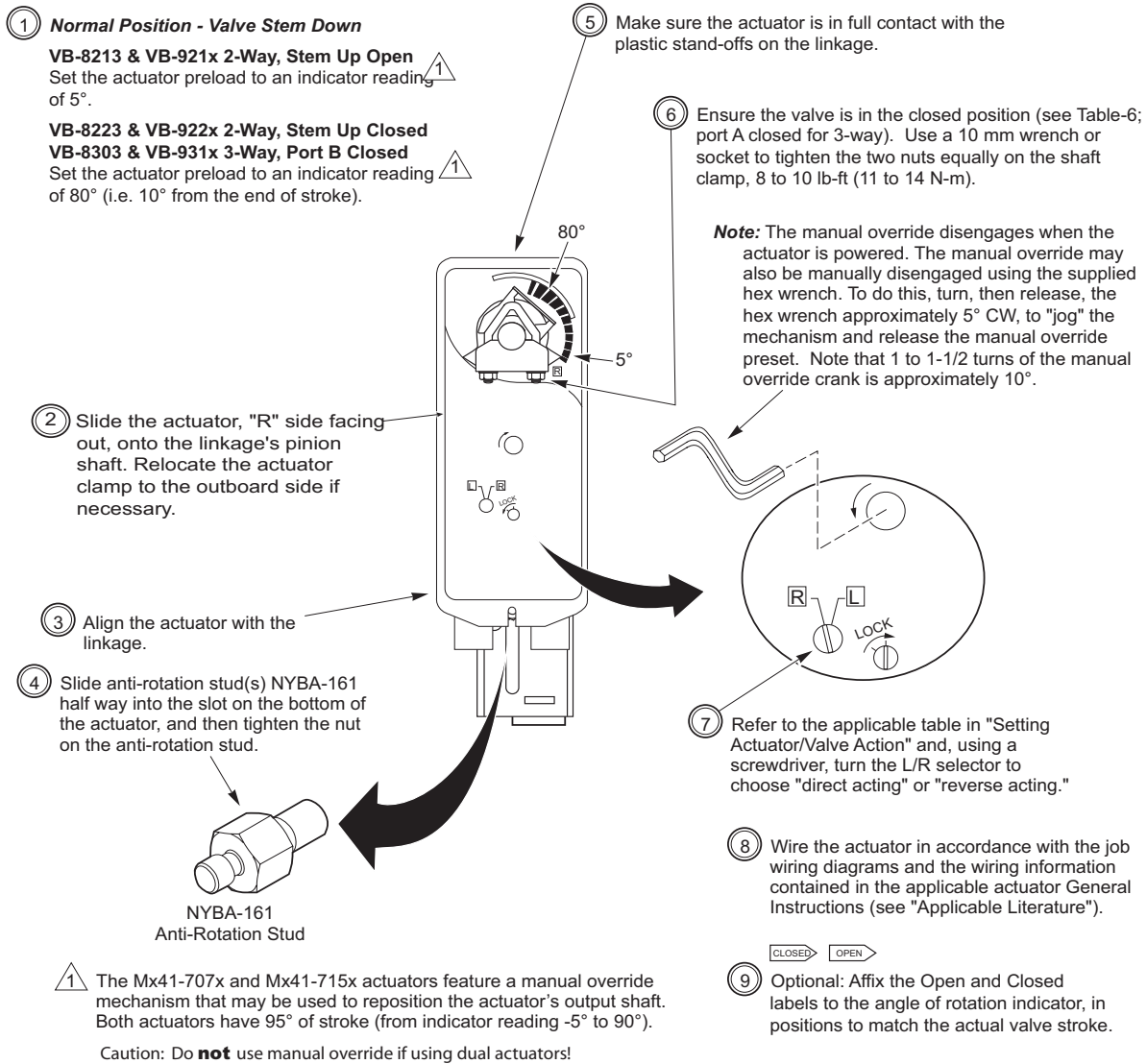

Figure-5 Mounting Mx41-707x or M41-715x and Setting Up Actuator/Linkage/Valve

- b. Refer to the appropriate actuator General Instructions sheet for actuator wiring and application information (see “Applicable Literature” on page 2). For valve body installation and application information, refer to the appropriate valve body General Instructions sheet.

- c. Power the actuator(s) and check the system's operation for heating or cooling output, in response to the control signal. See “Setting Actuator/Valve Action” on page 10.

### B3. Non-Spring Return Actuator with Manual Override

VB-8213 and VB-921x 2-Way Valves (Valve Stem Up, Open)  
 VB-8223 and VB-922x 2-Way Valves (Valve Stem Up, Closed)  
 VB-8303 and VB-931x 3-Way Valves (Valve Stem Up, Port A Closed)

Mx41-6153 Series (VB-9xxx only) Actuator with AV-607-1 Linkage, Mx41-634x Actuator with AV-609-1 Linkage Only

- a. Install the actuator (or actuators if using dual Mx41-6153 actuators) onto the linkage and valve, and set up the assembly, according to Figure-7 on page 8 and Table-4 on page 11 or Table-5 on page 12.

**Note:** If using dual actuators, make sure both rotate in the same direction. Do not use manual override on installed actuators if using dual actuators. See "General Installation" on page 3.

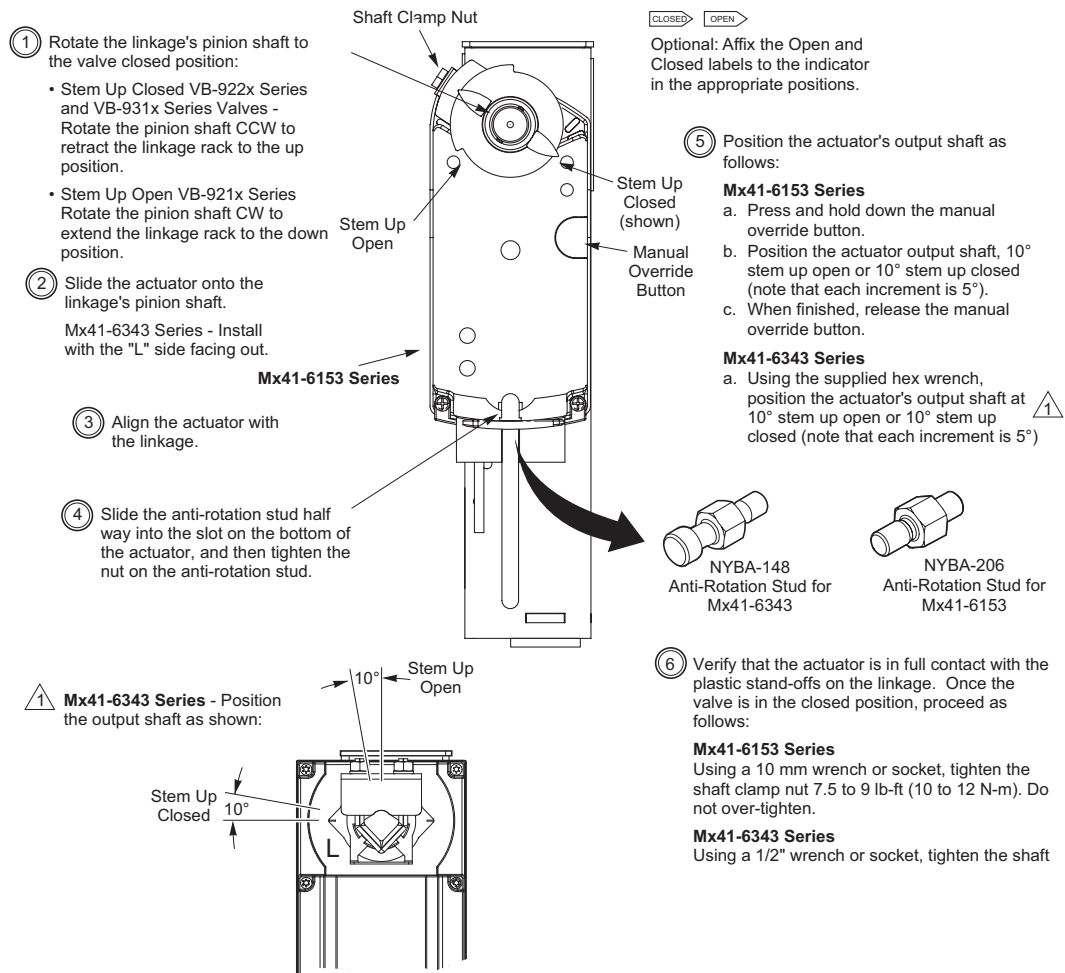

Figure-6 Mounting Mx41-6153 Series or Mx41-634x Series Actuator and Setting Up Actuator/Linkage/Valve

- Refer to the appropriate actuator General Instructions sheet for actuator wiring and application information (see "Applicable Literature" on page 2). For valve body installation and application information, refer to the appropriate valve body General Instructions sheet.
- Power the actuator(s) and check the system's operation for heating or cooling output, in response to the control signal. See "Setting Actuator/Valve Action" on page 10.

B4. Spring Return Actuators without Manual Override

VB-8223, VB-922x 2-Way Valves (Normal Position — Valve Stem Up, Closed)  
 VB-8303, VB-931x 3-Way Valves (Normal Position — Valve Stem Up, Port A Closed)

Mx40-717x (AV-607-1 and AV-609-1)

- a. Install the actuator (or actuators if using dual actuators) onto the linkage and valve, and set up the assembly, according to Table-3 on page 11. Use the two clamps supplied with the linkage.

**Note:** If using dual actuators, make sure both rotate and spring return in the same direction.

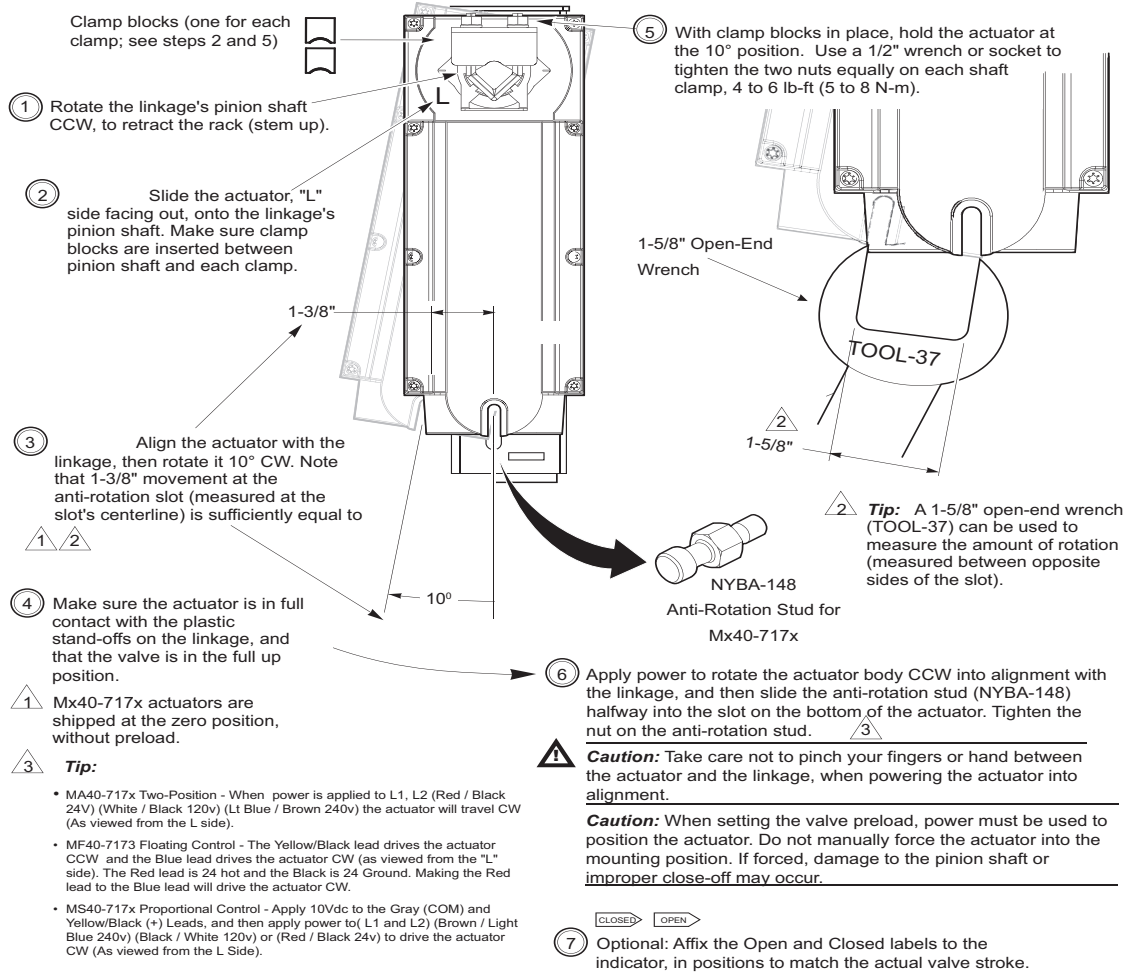

Figure-7 Mounting Mx40-717x and Setting Up Actuator/Linkage/Valve

- b. Refer to the appropriate actuator General Instructions sheet for actuator wiring and application information (see "Applicable Literature" on page 2). For valve body installation and application information, refer to the appropriate valve body General Instructions sheet.
- c. Power the actuator(s) and check the system's operation for heating or cooling output, in response to the control signal. See "Setting Actuator/Valve Action" on page 10.



B5. Spring-Return Actuators without Manual Override

VB-8213, VB-921x 2-Way Valves (Normal Position — Valve Stem Down, Closed)  
 VB-8303, VB-931x 3-Way Valves (Normal Position — Valve Stem Down, Port B Closed)

Mx40-717x (AV-607-1 and AV-609-1)

- a. Install the actuator (or actuators if using dual actuators) onto the linkage and valve, and set up the assembly, according to and Table-3 on page 11. Use the two clamps supplied with the linkage.

**Note:** If using dual actuators, make sure both rotate and spring return in the same direction.

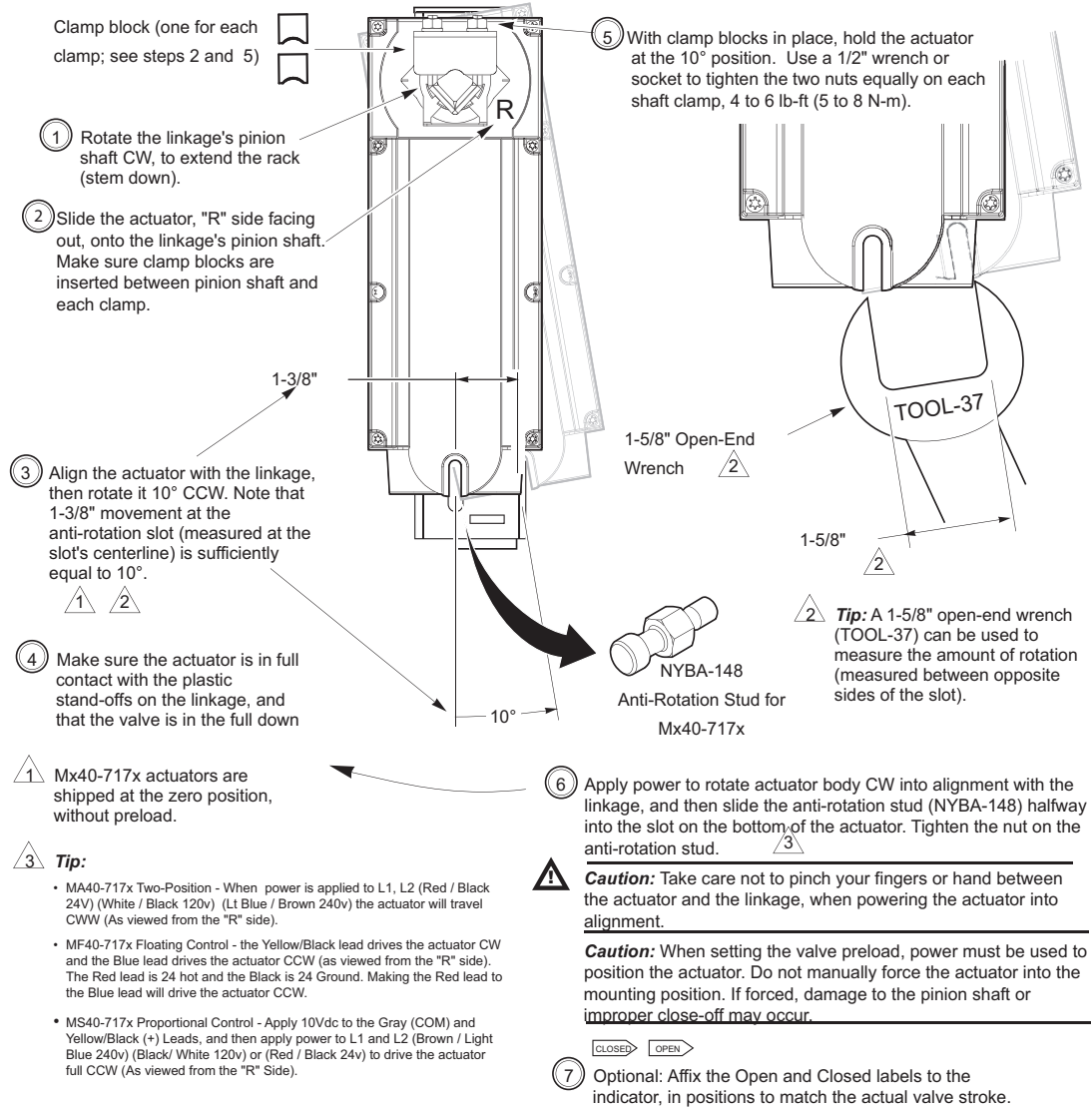

Figure-8 Mounting Mx40-717x and Setting Up Actuator/Linkage/Valve

- b. Refer to the appropriate actuator General Instructions sheet for actuator wiring and application information (see "Applicable Literature" on page 2). For valve body installation and application information, refer to the appropriate valve body General Instructions sheet.
- c. Power the actuator(s) and check the system's operation for heating or cooling output, in response to the control signal. See "Setting Actuator/Valve Action" on page 10.

## Setting Actuator/Valve Action

Set the actuator/valve action according to Table-2, Table-3, Table-4, or Table-6.

These tables may also be used to check the action of the completed actuator/linkage/valve assembly.

Table-2 Mx41-707x Mx41-715x Series Spring Return Actuators.

Valve Part Number	Primary <sup>a</sup> Actuator		Secondary <sup>b</sup> Actuator		Control Signal Increase				Spring Return		
	Facing Side	Switch Setting	Facing Side	Switch Setting	Primary Actuator Rotation <sup>c</sup>	Secondary Actuator Rotation <sup>c</sup>	Valve Stem Moves	Valve Action	Primary Actuator Rotation <sup>c</sup>	Secondary Actuator Rotation <sup>c</sup>	Valve Normal Position
VB-921x	L	L	R	R	CW	CCW	Down	Closes	CCW	CW	Open (Stem Up)
	L	R	R	L	CCW	CW	Up	Opens	CCW	CW	
VB-8213	R	L	L	R	CW	CCW	Down	Closes	CW	CCW	Closed (Stem Down)
	R	R	L	L	CCW	CW	Up	Opens	CW	CCW	
VB-922x	L	L	R	R	CW	CCW	Down	Opens	CCW	CW	Closed (Stem Up)
	L	R	R	L	CCW	CW	Up	Closes	CCW	CW	
VB-8223	R	L	L	R	CW	CCW	Down	Opens	CW	CCW	Open (Stem Down)
	R	R	L	L	CCW	CW	Up	Closes	CW	CCW	
VB-931x	L	L	R	R	CW	CCW	Down	"A" Opens "B" Closes	CCW	CW	"A" Closed "B" Open (Stem Up)
	L	R	R	L	CCW	CW	Up	"A" Closes "B" Opens	CCW	CW	
	R	L	L	R	CW	CCW	Down	"A" Opens "B" Closes	CW	CCW	"A" Open "B" Closed (Stem Down)
	R	R	L	L	CCW	CW	Up	"A" Closes "B" Opens	CW	CCW	
VB-8303	L	L	R	R	CW	CCW	Down	"A" Opens "B" Closes	CCW	CW	"A" Closed "B" Open (Stem Up)
	L	R	R	L	CCW	CW	Up	"A" Closes "B" Opens	CCW	CW	
	R	L	L	R	CW	CCW	Down	"A" Opens "B" Closes	CW	CCW	"A" Open "B" Closed (Stem Down)
	R	R	L	L	CCW	CW	Up	"A" Closes "B" Opens	CW	CCW	

<sup>a</sup>Primary actuator is mounted on side of linkage with rack not visible

<sup>b</sup>Secondary actuator is mounted on side of linkage with rack visible.

<sup>c</sup>As viewed facing actuator.

Table- 3 MA40-717x Spring Return Actuators.

Valve Part Number	Primary <sup>a</sup> Actuator	Secondary <sup>b</sup> Actuator	Control Signal Increase				Spring Return		
	Facing Side	Facing Side	Primary Actuator Rotation <sup>c</sup>	Secondary Actuator Rotation <sup>c</sup>	Valve Stem Moves	Valve Action	Primary Actuator Rotation <sup>c</sup>	Secondary Actuator Rotation <sup>c</sup>	Valve Normal Position
VB-921x VB-8213	L	R	CW	CCW	Down	Closes	CCW	CW	Open (Stem Up)
	R	L	CCW	CW	Up	Opens	CW	CCW	Closed (Stem Down)
VB-922x VB-8223	L	R	CW	CCW	Down	Opens	CCW	CW	Closed (Stem Up)
	R	L	CCW	CW	Up	Closes	CW	CCW	Open (Stem Down)
VB-931x	L	R	CW	CCW	Down	"A" Opens "B" Closes	CCW	CW	"B" Open, "A" Closed (Stem Up)
	R	L	CCW	CW	Up	"A" Opens "B" Closes	CW	CCW	"A" Open, "B" Closed (Stem Down)
VB-8303	L	R	CW	CCW	Down	"A" Opens "B" Closes	CCW	CW	"B" Open, "A" Closed (Stem Up)
	R	L	CCW	CW	Up	"A" Closes "B" Opens	CW	CCW	"A" Open, "B" Closed (Stem Down)

<sup>a</sup>Primary actuator is mounted on side of linkage with rack not visible

<sup>b</sup>Secondary actuator is mounted on side of linkage with rack visible.

<sup>c</sup>As viewed facing actuator.

Table-4 MF41-6153 Floating, MS41-6153 Proportional Non-Spring Return Actuators (AV-607-1 Only)

Valve Part Number	Control Signal Increase			
	Primary <sup>a</sup> Actuator Rotation <sup>b</sup>	Secondary <sup>c</sup> Actuator Rotation <sup>b</sup>	Valve Stem Moves	Valve Action
VB-921x VB-8213	CW <sup>d</sup>	CCW <sup>e</sup>	Down	Closes
	CCW <sup>e</sup>	CW <sup>d</sup>	Up	Opens
VB-922x VB-8223	CW <sup>d</sup>	CCW <sup>e</sup>	Down	Opens
	CCW <sup>e</sup>	CW <sup>d</sup>	Up	Closes
VB-931x	CW <sup>d</sup>	CCW <sup>e</sup>	Down	"A" Opens, "B" Closes
	CCW <sup>e</sup>	CW <sup>d</sup>	Up	"A" Closes, "A" Opens
VB-8303	CW <sup>d</sup>	CCW <sup>e</sup>	Down	"A" Opens, "B" Closes
	CCW <sup>e</sup>	CW <sup>d</sup>	Up	"A" Closes, "A" Opens

<sup>a</sup>Primary actuator is mounted on side of linkage with rack not visible

<sup>b</sup>Secondary actuator is mounted on side of linkage with rack visible.

<sup>c</sup>As viewed facing actuator. MF models: control signal applied to Wire 6 (Y1).

<sup>d</sup>MF models: control signal applied to Wire 6 (Y1). MS models: DIP switch set to "CW".

<sup>e</sup>MF models: control signal applied to Wire 7 (Y2). MS models: DIP switch set to "CCW".

Table-5 Mx41-6343 Floating and Mx41-634x Proportional Non-Spring Return Actuator (AV-609-1 Only)

Valve Part Number	Primary <sup>a</sup> Actuator	Secondary <sup>b</sup> Actuator	Control Signal Increase			
	Facing Side	Facing Side	Primary Actuator Rotation <sup>c</sup>	Secondary Actuator Rotation <sup>c</sup>	Valve Stem Moves	Valve Action
VB-921x VB-8213	L	R	CW	CCW	Down	Closes
	R	L	CCW	CW	Up	Opens
VB-922x VB-8223	L	R	CW	CCW	Down	Opens
	R	L	CCW	CW	Up	Closes
VB-931x	L	R	CW	CCW	Down	"A" Opens, "B" Close
	R	L	CCW	CW	Up	"A" Closes, "B" Opens
VB-8303	L	R	CW	CCW	Down	"A" Opens, "B" Closes
	R	L	CCW	CW	Up	"A" Closes, "B" Opens

<sup>a</sup>Primary actuator is mounted on side of linkage with rack not visible

<sup>b</sup>Secondary actuator is mounted on side of linkage with rack visible.

<sup>c</sup>As viewed facing actuator.

## Valve Body Action

Table-6 Valve Body Action

Valve Body Part Number	Description	Valve Action	
		Stem Up	Stem Down
VB-8213	Two-way stem up open	Open	Closed
VB-8223	Two-way stem up closed	Closed	Open
VB-8303	Three-way diverting / mixing <sup>a</sup>	Port A Closed Port B Open <sup>a</sup>	Port A Open Port B Closed <sup>a</sup>
VB-921x	Two-way stem up open	Open	Closed
VB-922x	Two-way stem up closed	Closed	Open
VB-931x	Three-way mixing <sup>a</sup>	Port A Closed Port B Open <sup>a</sup>	Port A Open Port B Closed <sup>a</sup>

<sup>a</sup>AB port is the common port on 3-way valves