

Applications

The AM-756 metric conduit adaptor is used with the following actuator series: MX40-704X, MX4X-707X, MX4X-715X, MX40-717X, and MX40-634X.

The AM-756 is used to adapt the actuator to the electrical conduit when the conduit has metric M20 threads. Two adaptors are in each kit.

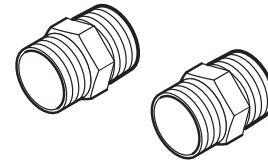

AM-756

Features

- Adapts 1/2 inch NPT threads to M20 threads

Specifications

- Zinc plated, low carbon steel

Dimensions

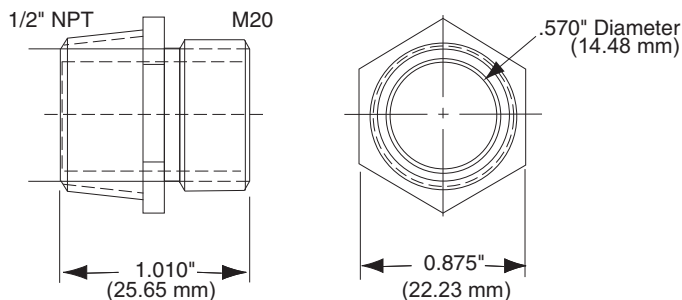

On October 1st, 2009, TAC became the Buildings business of its parent company Schneider Electric. This document reflects the visual identity of Schneider Electric, however there remains references to TAC as a corporate brand in the body copy. As each document is updated, the body copy will be changed to reflect appropriate corporate brand changes.

Copyright 2010, Schneider Electric
All brand names, trademarks and registered trademarks are the property of their respective owners. Information contained within this document is subject to change without notice.

Schneider Electric
1354 Clifford Avenue
P.O. Box 2940
Loves Park, IL 61132-2940

www.schneider-electric.com/buildings