

NEMA 4 Rated Gasket Cover Kit For MC and MP-9000 Series Actuators General Instructions

Application

The NEMA 4 rated gasket cover kit is designed to provide the internal components MC and MP-9000 series actuators with a degree of protection against wind-blown dust, rain and hose directed water.

Features

- Provides weather protection for the MC and MP-9000 series Electric Actuators
- Permits use in NEMA Type 4 locations

Applicable Literature

- Cross-Reference Guide, F-23638
- Reference Manual, F-12683
- Systems Catalog, F-16650
- MC and MP-9000 High Torque Oil Submerged Actuators General Instructions, F-11331

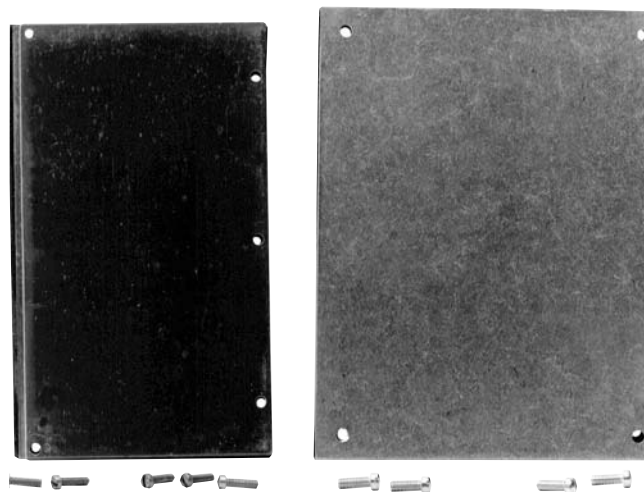

SPECIFICATIONS

Construction: Top and Back gasketed aluminum covers.

NOTE

Back cover plate prevents the use of AM-321, AM-332, AM-341, AM-342 and AM-345 accessory kits.

Table-1 AM-369 Package Contains.

Quantity	Description
1	top cover plate
1	back cover plate
4	#6-32 top cover plate screws
5	#8-32 back cover plate screws

INSTALLATION

Inspection

Inspect the package for damage. If damaged, notify the appropriate carrier immediately. If undamaged, open the package and inspect the device for obvious damage. Return damaged products.

Requirements



- Tools (not provided): Appropriate screwdriver for the mounting screws used in the gasket cover kit
- Training: Installer must be a qualified, experienced technician

▼ **WARNING**

Disconnect power supply before installation to prevent electrical shock and equipment damage.

▼ **CAUTION**

- The Gasket Kit must be used with 1/2" conduit connectors of the *water tight* type T & B #5323 with T & B #5362 sealing rings or equivalent for NEMA Type 4 rated actuators.
- Do not exceed ratings of the actuator being used.

Mounting

1. Using a single slotted screwdriver remove the actuator's factory installed top and back covers.
2. Replace the top and back covers with the AM-369 Gasket Cover Kit (See Figure-1).
3. Install the gasket kit by using the screws provided in the kit.
4. Make sure the covers fit snugly before tighten screws.

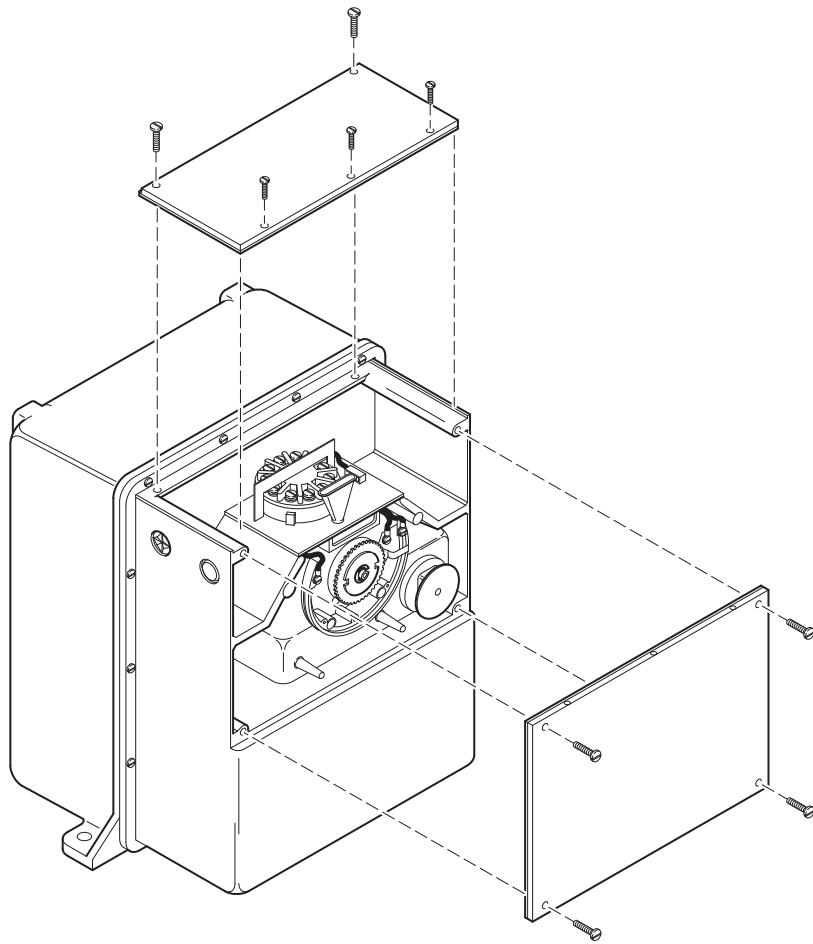

Figure-1 Gasket Cover Kit Used On The MP-9700 Actuator.

MAINTENANCE

The AM-369 Gasket Cover Kit requires no maintenance.

FIELD REPAIR

None. Replace any damaged or failed components with functional replacements.

DIMENSIONAL DATA

See Figure-2 for AM-369 Gasket Cover Kit dimensional data in inches (mm).

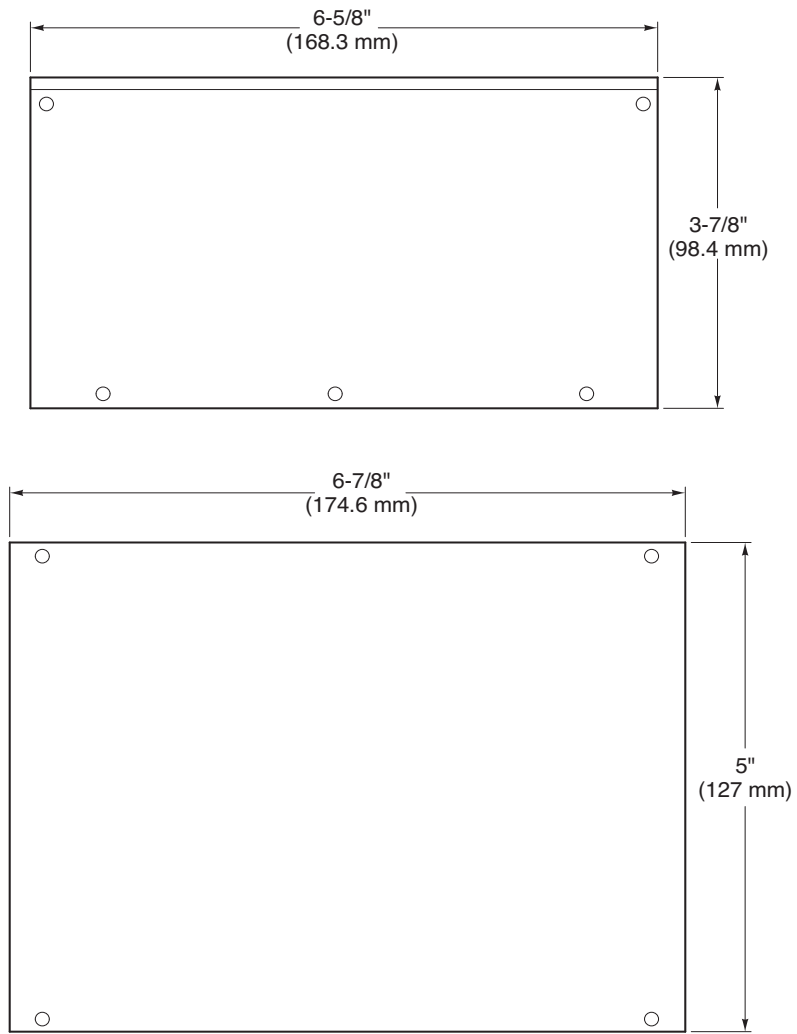

Figure-2 AM-369 Gasket Cover Kit Dimensions.

On October 1st, 2009, TAC became the Buildings business of its parent company Schneider Electric. This document reflects the visual identity of Schneider Electric, however there remains references to TAC as a corporate brand in the body copy. As each document is updated, the body copy will be changed to reflect appropriate corporate brand changes.

Copyright 2010, Schneider Electric
All brand names, trademarks and registered
trademarks are the property of their respective
owners. Information contained within this
document is subject to change without notice.

Schneider Electric
1354 Clifford Avenue
P.O. Box 2940
Loves Park, IL 61132-2940

www.schneider-electric.com/buildings

Schneider
Electric