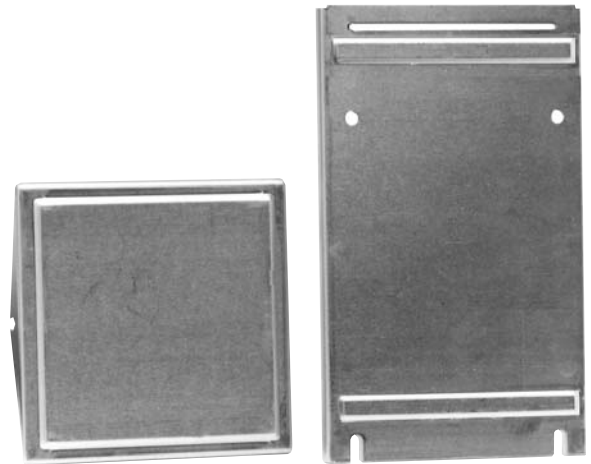

**NEMA 4 Rated Gasket Cover Kit  
General Instructions**

F-25598

**Application**

The NEMA 4 rated gasket cover kit is designed to provide the internal components of non-spring return oil-submerged gear train actuators with a degree of protection against wind-blown dust, rain and hose directed water. The kit is designed to be used on MC and MP-3XX, 4XX, 2XXX, and 4XXX actuators.

**Features**

- Provides weather protection for the MC and MP-3XX, 4XX, 2XXX and 4XXX series of non-spring return Electric Actuators
- Permits use in NEMA Type 4 locations

**Applicable Literature**

- Schneider Electric Cross-Reference Guide, F-23638
- Schneider Electric Reference Manual, F-12683
- Electric/Electronic Products Catalog, F-27382
- MP-Series Reversible and Proportional Electric Actuators General Instructions, F-15479
- MC-Series Three-Wire Two-Position Actuators General Instructions, F-8366

## SPECIFICATIONS

**Construction:** Top and Back gasketed aluminum covers.

### NOTE

---

- The back cover plate prevents the use of AM-321, AM-332, AM-341, and AM-342 accessory kits.
  - The AM-363 can not be used with MP-36X, 37X, 46X, 47X, 46XX, and 47XX spring return actuators.
- 

**Table-1 AM-363 Package Contains.**

Quantity	Description
1	top cover plate
1	back cover plate
5	screws

## INSTALLATION

### Inspection

Inspect the package for damage. If damaged, notify the appropriate carrier immediately. If undamaged, open the package and inspect the device for obvious damage. Return damaged products.

### Requirements



- Tools (not provided): Appropriate screwdriver for the mounting screws used in the gasket cover kit
- Training: Installer must be a qualified, experienced technician

### ▼ WARNING

---

Disconnect power supply before installation to prevent electrical shock and equipment damage.

---

### ▼ CAUTION

---

- The Gasket Kit must be used with 1/2" conduit connectors of the *water tight* type T & B #5323 with T & B #5362 sealing rings or equivalent for NEMA Type 4 rated actuators.
  - Do not exceed ratings of the actuator being used.
- 

### Mounting

1. Using a single slotted screwdriver remove the actuator's factory installed top and back covers.
2. Replace the top and back covers with the AM-363 Gasket Cover Kit (See Figure-1).
3. Mount the gasket kit by using the screws provided with the actuator.
4. Make sure the covers fit snugly before tighten screws.

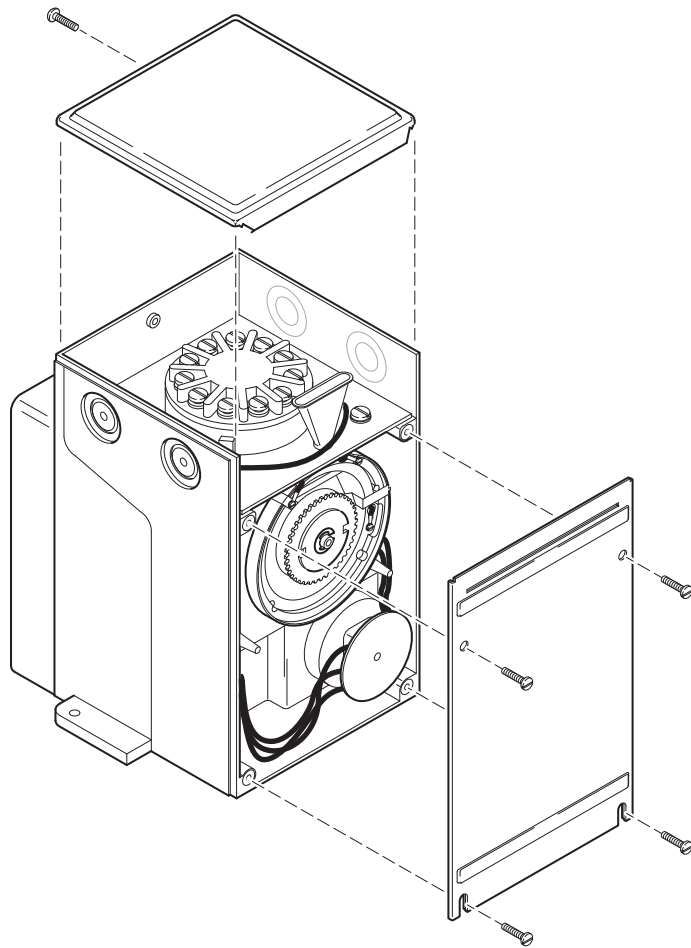

Figure-1 Gasket Cover Kit Used On The MP-381 Actuator.

## MAINTENANCE

The AM-363 Gasket Cover Kit requires no maintenance.

## FIELD REPAIR

None. Replace any damaged or failed components with functional replacements.

## DIMENSIONAL DATA

See Figure-2 for AM-363 Gasket Cover Kit dimensional data in inches (mm).

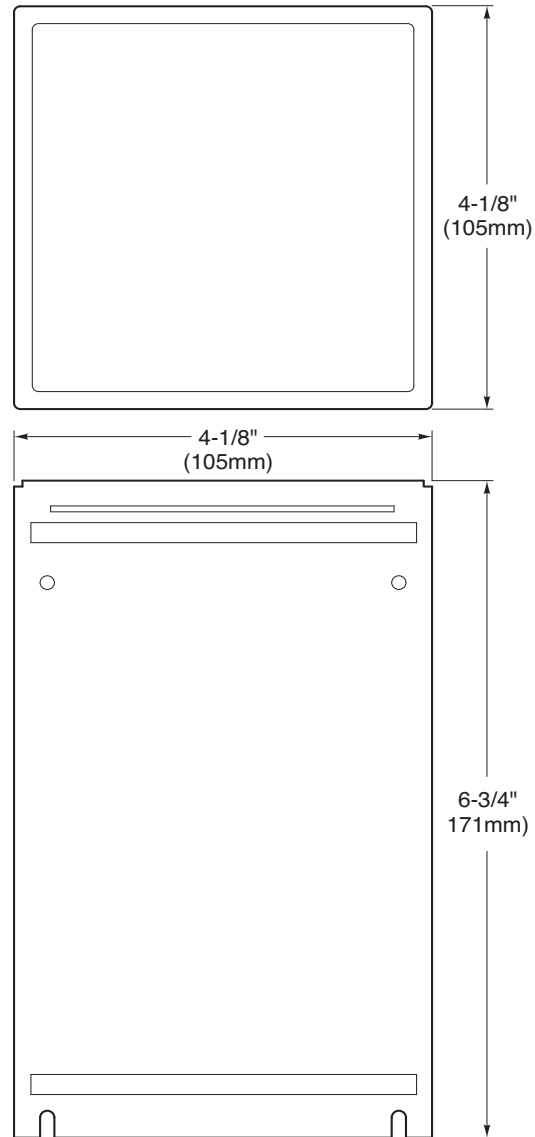

Figure-2 AM-363 Gasket Cover Kit Dimensions.

On October 1st, 2009, TAC became the Buildings business of its parent company Schneider Electric. This document reflects the visual identity of Schneider Electric, however there remains references to TAC as a corporate brand in the body copy. As each document is updated, the body copy will be changed to reflect appropriate corporate brand changes.

Copyright 2010, Schneider Electric  
All brand names, trademarks and registered  
trademarks are the property of their respective  
owners. Information contained within this  
document is subject to change without notice.

**Schneider Electric**  
1354 Clifford Avenue  
P.O. Box 2940  
Loves Park, IL 61132-2940  
[www.schneider-electric.com/buildings](http://www.schneider-electric.com/buildings)

**Schneider**  
 **Electric**