

**Ratio/Amplifying Relay
General Instructions**

The 2378-501 Amplifying Relay is a proportioning device designed for use in pneumatic control systems where the application requires the amplification of a proportional signal from a controlling device. The 2378-501 branch line pressure output increases as a 2:1 ratio to the input signal pressure (up to main air pressure) and amplifies the volume of air available to the final control device, thereby minimizing system lag.

The unit is factory adjusted for a 10 psig branch pressure at a signal pressure of 5 psig. A bias adjustment is provided which permits the effect of the input signal pressure to be decreased up to 9 psig from the actual input pressure (see Figure-2).

ORDERING INFORMATION

Table-1 Relay.

TAC Model Number	Replaces Model	Function
2378-501	R539	2:1 Amplifying
22-150	K502	Optional Mtg. Bracket

Table-2 Active Connections.

PORT	CONNECTED TO
M	Main air
B	Branch output
S1	Input Signal

GENERAL INSTRUCTIONS

This device is to be used on clean, dry, oil free control air only and will operate properly when mounted in any position.

The inherent reliability of this device is enhanced and prolonged through regular inspection and preventive maintenance by a qualified control expert. Should this device become inoperative, it should be replaced by a new unit.

SPECIFICATIONS

- Action:** Proportional output at 2:1 ratio.
- Adjustments:** Bias can be manually adjusted from +5 psig to -13 psig by means of a 5/64" hex wrench.
- Main Air Pressure:** 20 psig operating 30 psig maximum.
- Air Capacity:** 8 scfh.
- Air Consumption:** 1 scfh.
- Maximum Ambient Temperature:** 140 °F.

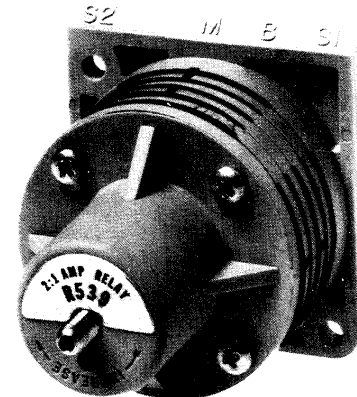

2378-501

Mounting: Designed for use on 22-120 socket. These devices can also be surface mounted by using the appropriate mounting bracket (see Mounting Instructions).
Connections: Barbed nipples for 1/4" OD polyethylene or 5/32" ID polyurethane tubing.
Material: Glass-filled nylon.

MOUNTING INSTRUCTIONS & DIMENSIONS

Panel Mounting

This device has been designed to be mounted on a 22-120 socket. One socket, one gasket, and two mounting screws are required in addition to the appropriate manifold backplate.

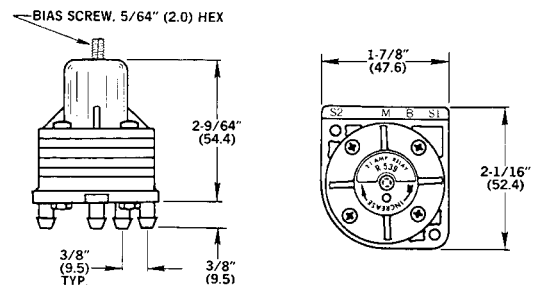

Field Mounting

This device may also be mounted without the backplate, socket, and gasket to replace competitive devices by using the plastic mounting strap and adhesive base provided.

TYPICAL APPLICATION

In the application shown, the controller operates the heating valve, outside and return air dampers, and the cooling valve in sequence. The heating valve operates directly from the controller signal and is fully opened at 2 psig and closed at 7 psig. To ensure the proper sequence, the bias of the ratio relay is set to -7 psig (input signal plus or minus the bias times two). As the controller output rises from 9 psig (relay output 4 psig) to 13.5 psig (relay output 13 psig), the dampers and cooling valve are operated in sequence.

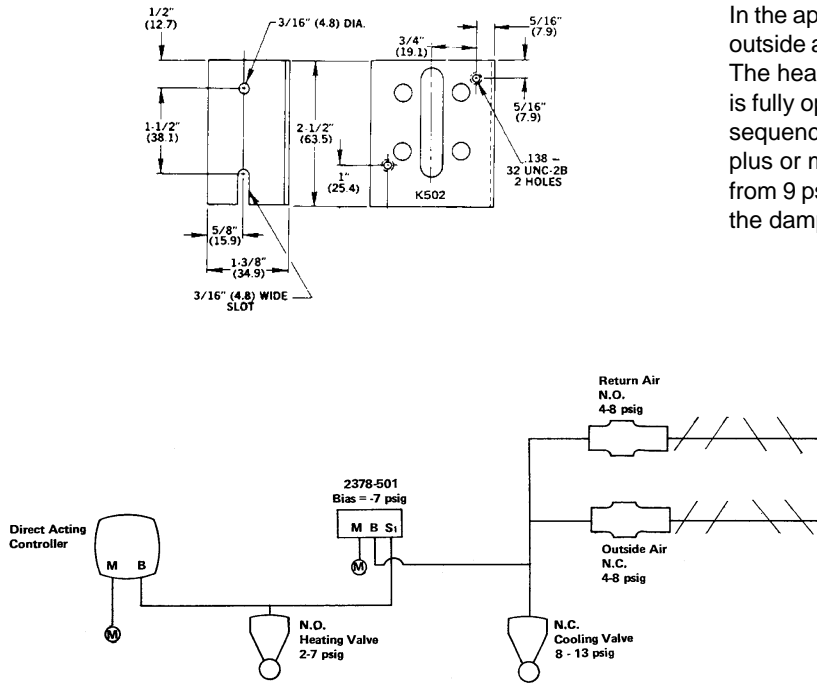

Figure-1

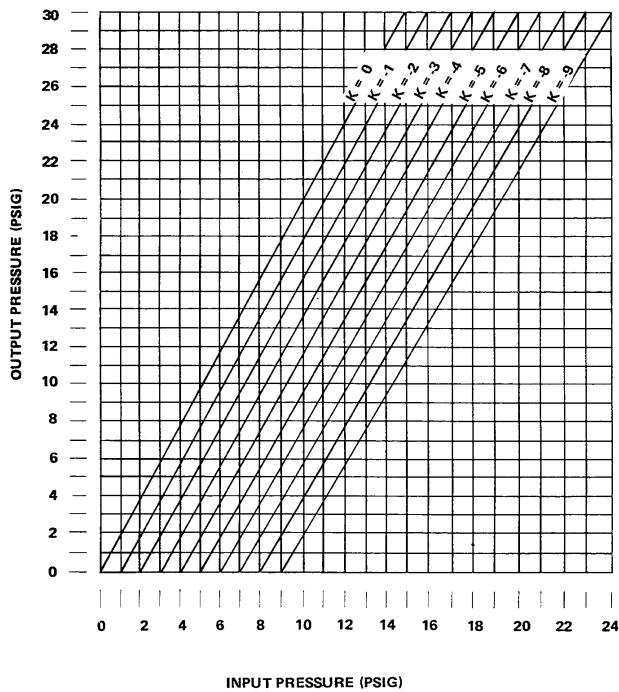

Figure-2 Input vs Output (K = Bias)

On October 1st, 2009, TAC became the Buildings business of its parent company Schneider Electric. This document reflects the visual identity of Schneider Electric, however there remains references to TAC as a corporate brand in the body copy. As each document is updated, the body copy will be changed to reflect appropriate corporate brand changes.

Copyright 2010, Schneider Electric
All brand names, trademarks and registered trademarks are the property of their respective owners. Information contained within this document is subject to change without notice.

Schneider Electric
1354 Clifford Avenue
P.O. Box 2940
Loves Park, IL 61132-2940

www.schneider-electric.com/buildings

Schneider
Electric