

Electronic Remote Temperature Sensors General Instructions

APPLICATION

Electronic sensing of temperature at remote room locations, ducts, plenum chambers, liquid lines, tanks, outdoor air, and similar applications.

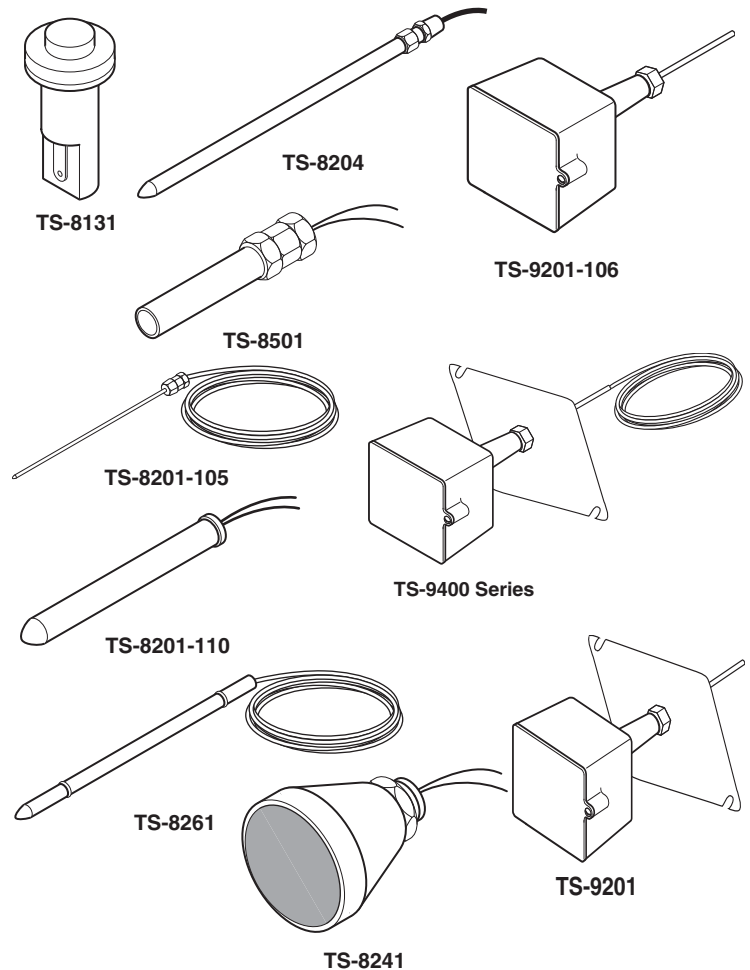

SPECIFICATIONS

Sensing Element: Balco resistance, 1000 ohms $\pm 0.1\%$ at 70°F (21°C); **TS-9405, TS-9422:** $\pm 1\%$ at 70°F (21°C). Changes 2.2 ohms per 1 F°(0.5 C°) at 70°F (21°C). **TS-8204 only:** 1657 ohms $\pm 0.1\%$ at 300°F (149°C); changes 2.5 ohms per 1 F°(0.5 C°) at 300°F (149°C).

Note: TS-8204 is not compatible with internal setpoints of controllers (except for differential control), TSP-8101 or TSP-8111 temperature transmitters. Order AT-8435, 200 to 400°F (93 to 204°C) when setpoint is required.

See Tables 1 and 2 for additional specifications.

ACCESSORIES

AT-208	Duct mounting kit for TS-8201-105 (included with TS-8204).
AT-211	Outdoor bulb shield.
AT-215	Stainless steel bulb well for TS-9201, TS-8201-105 or TS-8204.
AT-225	Stainless steel bulb well for TS-9201-106.
AT-226	High pressure brass well.
AT-8435	Remote setpoint adjuster, dual scale 200 to 400°F (93 to 204°C): required for all TS-8204 applications except differential control.

Table-1 AMBIENT TEMPERATURE LIMITS.

Part Number	Shipping & Storage °F (°C)	Operating °F (°C)
TS-8131 ^a TS-8241 ^a TS-8261 ^a	-40 to 160 (-40 to 71)	-40 to 140 (-40 to 60)
TS-9201 TS-8201-105 TS-9201-106 TS-8201-110	-40 to 250 (-40 to 121)	-40 to 250 (-40 to 121)
TS-9405 TS-9422 TS-8501	-40 to 220 (-40 to 104)	-40 to 220 (-40 to 104)
TS-8204	-40 to 400 (-40 to 204)	200 to 400 (93 to 204)

^a Humidity, 5 to 95% RH, non-condensing.

Table-2 SPECIFICATIONS.

Part Number	Description	Mounting Connection	Dimensions in. (mm)		Wiring Connections
			Element	Wiring Enclosure	
TS-8131	Unitary ^a	7/32" (13.5 mm) dia. Mounting Hole	3/4 dia. x 1-1/4 long (19 x 32)	None	1/4 in. Spade Connections
TS-8201-105	Duct/Immersion ^b	1/4" NPT Nut ^b	1/4 dia. x 8 long (6 x 203)	None	10 ft (3 m) Armored Capillary with additional 6" (152 mm) leads
TS-9201	Duct/Immersion ^b	Flange, 1/4" NPT ^b	1/4 dia. x 6 long (6 x 152)	2-7/8 H x 2-3/8 W x 1-1/2 D (73 x 60 x 38) with 2-1/2 (64) extension to element; 1/2" knockout (top)	12 in. (305 mm) Black Pigtail Leads
TS-9201-106	Immersion ^c	1/4" NPT Nut ^c	1/4 dia. x 4 long (6 x 102)		
TS-8201-110	Strap-on	Nylon Wire Tie ^d	1/4 dia. x 2-1/4 long (6 x 57)	None	12 in. (305 mm) Black Pigtail Leads
TS-8204	Duct/Immersion ^b	1/4" NPT Nut ^e AT-208 included	1/4 dia. x 8 long (6 x 203)	None	16 in. (401 mm) Yellow Pigtail Leads
TS-8241	Ceiling Diffuser	7/16" (11.1 mm) Mounting Hole	1-5/8 dia. x 1-3/4 long (41 x 44)	None	20 ft (6.1 m) Black Pigtail Leads
TS-8261	Combination Light Fixtures & Ceiling Diffuser	None	1/4 dia. x 8-1/8 long (6 x 206)	None	6 ft (1.8 m) Black Pigtail Leads
TS-9405	Averaging (Duct)	Flange	5 ft (1.5 m) long	2-7/8 H x 2-3/8 W x 1-1/2 D (73 x 60 x 38) with 2-1/2 (64) extension to element; 1/2" knockout (top)	12 in. (305 mm) Black Pigtail Leads
TS-9422	Averaging (Duct)	Flange	22 ft (6.7 m) long		
TS-8501	Outdoor	1/2" Conduit	1-1/8 dia. x 5 long (29 x 127)	None	3 ft (0.9 m) Black Pigtail Leads

^a For mounting through fan coil of unit ventilator cabinet or similar application.

^b Immersion requires AT-215 or AT-226 bulb well.

^c Immersion requires AT-225 bulb well.

^d Factory supplied 2-1/2 x 2 in. (64 x 51 mm) foam insulation tape and 30 in. (762 mm) nylon wire tie for 1-1/2 thru 8 in. (38 thru 203 mm) diameter pipes.

^e AT-255 bulb well included.

INSTALLATION

Inspection

Visually inspect the carton for damage. If damaged, notify the appropriate carrier immediately. If undamaged, open the carton and visually inspect the device for obvious defects. Return damaged or defective products.

Required Installation Items

- Wiring diagrams
- Tools (not provided):
 - DVM (digital volt/ohm meter)
 - Appropriate screwdriver for mounting screws and terminal connections
 - Appropriate drill and drill bit for mounting screws
- Appropriate accessories
- Mounting screws, (2) #10 x 3/4" sheet metal, provided for TS-9201, TS-9405 and TS-9422 (TS-8204 contains mounting screws in AT-208 kit)

Caution: Installer must be a qualified, experienced technician. Make all connections in accordance with the wiring diagram, and in accordance with national and local electrical codes. Do not exceed the ratings of the device.

Mounting

Caution: Avoid locations where excessive vibration, moisture, corrosive fumes or vapors are present.

TS-8131 Unitary Sensor

1. Determine the sensor mounting location (Figure-1).
2. Drill 17/32" (13.5 mm) diameter mounting hole.
3. Insert gasket to base of sensor "button".
4. Insert sensor with gasket into mounting hole.
5. Secure sensor to mounting flange or surface by inserting Tinnerman nut over back of sensor.
6. Two crimp wire receptacles are provided for spade terminal connection to field wiring.

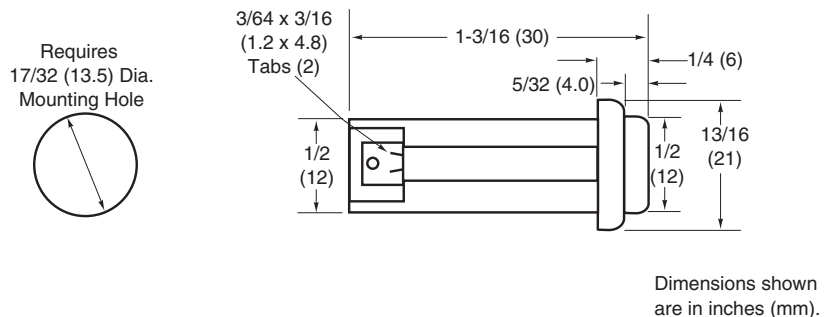

Figure-1 TS-8131 Mounting Dimensions.

TS-9201 Duct/Immersion Sensor

Duct

Note: Hand tighten only - do not overtighten.

1. Determine the sensor mounting location on the duct (predetermine the knockout hole location for routing of conduit). The sensing element is located within 1 inch of the end of the sensing probe, and it should be in the air stream at a location that is typical of the temperature requiring sensing. Approximately 3" of length adjustment is available.

2. Use the mounting flange supplied as a template (or refer to Figure-2 for duct mounting dimensions) for mounting hole location.
3. Mount the sensor to the duct using the two #10 x 3/4" sheet metal screws provided.

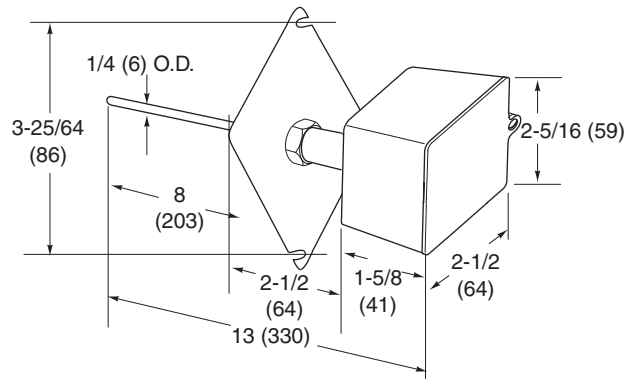

Dimensions shown
are in inches (mm).

Figure-2 TS-9201 Mounting Dimensions.

Immersion (Requires AT-215 Bulb Well)

1. Remove lock nut and duct mounting flange from sensor (Figure-3).
2. Thread the sensor into AT-215 bulb well that has been installed in a liquid line or tank.

Note: The AT-215 bulb well should be filled with a temperature conductive grease (TAC part number M-500) prior to element insertion, for optimum medium temperature sensing.

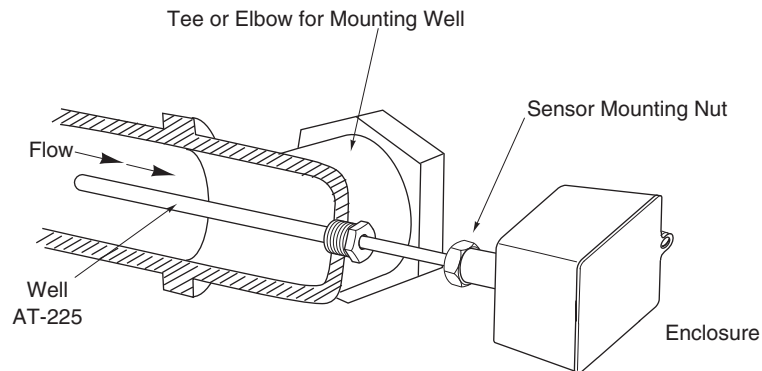

Figure-3 TS-9201 Immersion Mounting.

TS-8201-105 Duct/ Immersion Sensor

Duct (Requires AT-208 Duct Kit)

1. Determine the sensor mounting location on the duct. The sensing element is located within 1 inch of the end of the sensing probe and it should be located in the air stream typical of the temperature requiring sensing (see Figure-4).

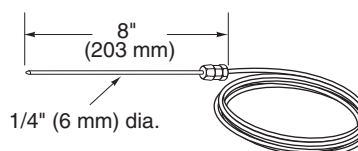
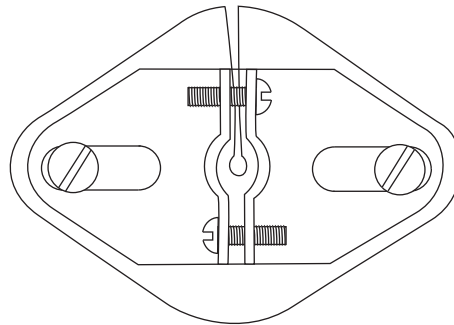

Figure-4 TS-8201-105 Mounting Dimensions.

2. Drill insertion and mounting holes for AT-208 in the duct wall (see Figure-5).

3. Mount the sensor the duct using the AT-208 kit.



AT-208 Bracket, Gasket and Mounting Screws

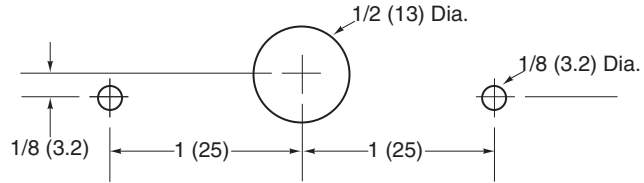

Full Scale - May be used as a template.

Dimensions shown
are in inches (mm).

Figure-5 AT-208 Mounting Dimensions.

Immersion (Requires AT-215 Bulb Well)

Thread the sensor into AT-215 bulb well that has been installed in a liquid line or tank.

Note: The AT-215 bulb well should be filled with a temperature conductive grease (TAC part number M-500) prior to element insertion, for optimum medium temperature sensing.

TS-8201-110 Strap-on Sensor

1. Foam insulation tape should be placed over the sensor (Figure-6). Extend insulation beyond the ends of the sensor.
2. Secure sensor and foam insulation tape to pipe with wire tie (factory supplied) or metal hose clamp (not included).

Caution: Do not tighten clamp or nylon tie (or metal hose clamp) to the point of distorting the sensor. Overtightening fasteners will cause a shift in sensed temperature.

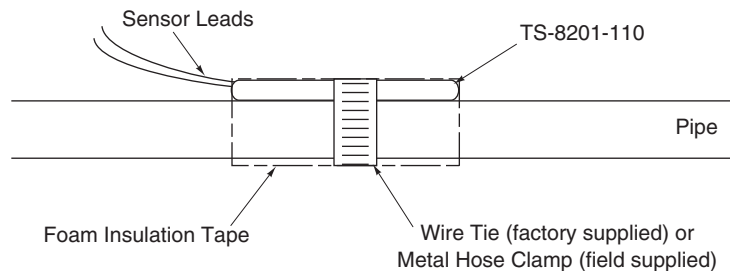

Figure-6 TS-8201-110 Strap-On Sensor Installation.

TS-9201-106 Immersion Sensor

Thread the sensor into AT-225 bulb well that has been installed in a liquid line or tank (see Figure-7).

Note: The AT-225 bulb well should be filled with a temperature conductive grease (TAC part number M-500) prior to element insertion, for optimum medium temperature sensing.

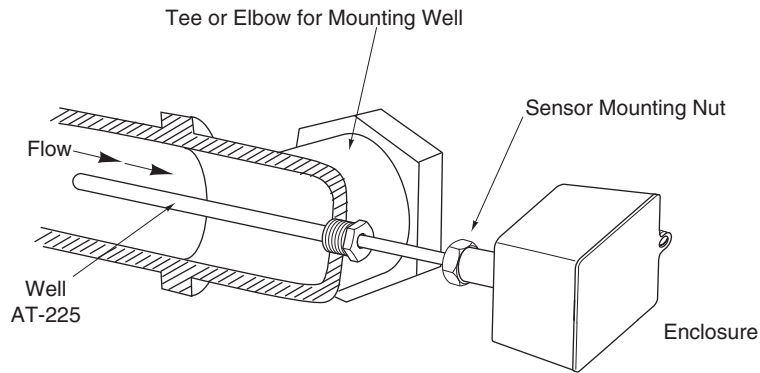

Figure-7 TS-9201-106 Immersion Mounting.

TS-8204 Duct/Immersion Sensor

Duct (Requires AT-208 Duct Kit)

1. Determine the sensor mounting location on the duct. The sensing element is located within 1" of the end of the sensing probe and it should be located in the air stream typical of the temperature requiring sensing (see Figure-8).
2. Drill insertion and mounting holes for AT-208 in the duct wall (see Figure-5).
3. Mount the sensor to the duct using the AT-208 kit.

Immersion (Requires AT-215 Bulb Well)

Thread the sensor into AT-215 bulb well that has been installed in a liquid line tank.

Note: The AT-215 bulb well should be filled with a temperature conductive grease (TAC part number M-500) prior to element insertion, for optimum medium temperature sensing.

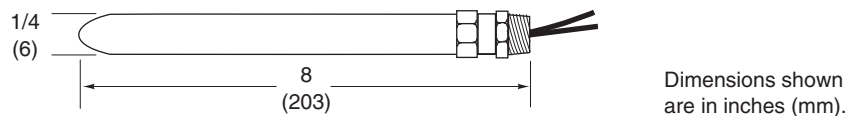

Figure-8 TS-8204 Mounting Dimensions.

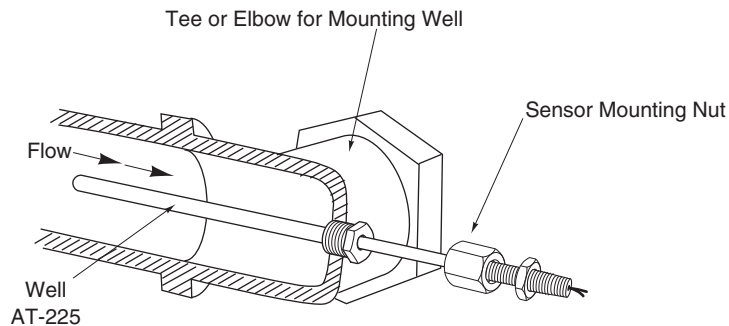

Figure-9 TS-8204 Immersion Mounting.

TS-8241 Duffuser

The sensor should be mounted to the face of the ceiling diffuser so that it projects downward into the room (see Figure-10).

1. Drill a 7/16" (11.1 mm) diameter mounting hole in the diffuser face.
2. Insert the threaded end of the sensor into the mounting hole.
3. Secure the sensor to the diffuser face using the mounting nut and lock washer provided.

If the diffuser has an adjustable pattern, the discharge air direction must be adjusted to a horizontal pattern. This horizontal pattern will insure a representative sample of room air over the element (see Figure-11). The sensor will not perform satisfactorily if the discharge is adjusted to a vertical pattern.

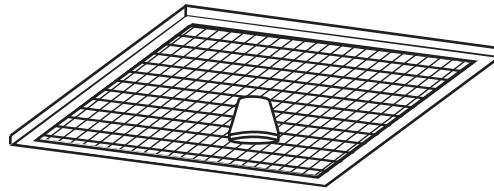

Figure-10 TS-8241 Sensor Mounted in Perforated Face Ceiling Diffuser.

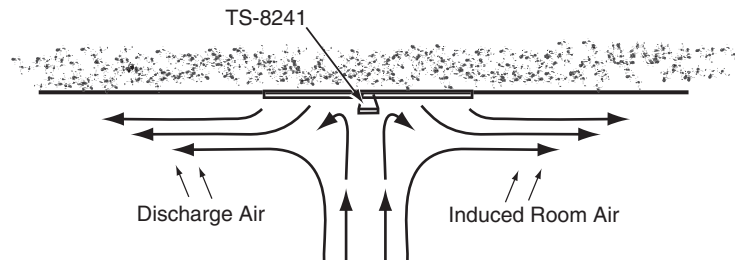

Figure-11 Room Air Induced over Sensor by Discharged Air.

TS-8261 Light Fixture or Ceiling Diffuser Sensor

The sensor may be mounted in the return air grill of a light fixture or to the face of a ceiling diffuser using field supplied fasteners (see Figure-12 and Figure-13).

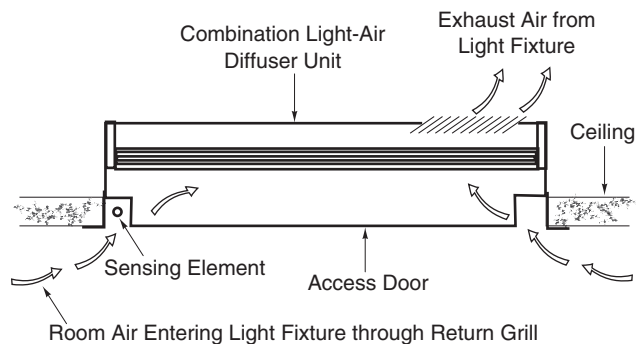

Figure-12 TS-8261 Sensor Mounted in Light-Air Diffuser Unit.

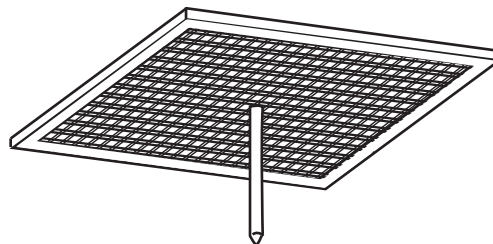

Figure-13 TS-8261 Sensor Mounted in Perforated Ceiling Diffuser.

TS-9405, TS-9422 Averaging Sensors

Note: Hand tighten only - do not overtighten.

1. Determine the sensor enclosure mounting location on the duct (see Figure 16) (predetermine the knockout hole location for routing of conduit). The sensor should be serpentine through the duct in a pattern that will expose it to all areas where variations of temperature may occur. If duct can not be entered, wrap the element around a section of conduit and place the conduit diagonally in the duct. Consider using part number M-648 mounting clips when the inside of the duct can be accessed.

Caution: Do not make sharp bends in the element.

2. Use the mounting flange supplied as a template (or refer to Figure 14 for duct mounting dimensions) for mounting hole location.
3. Mount the sensor enclosure to the duct using the two #10 x 3/4" sheet metal screws provided.

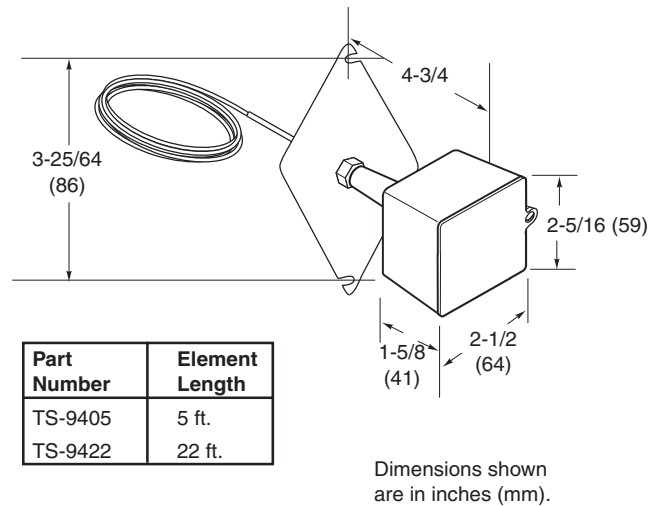

Figure-14 TS-9405/9422 Mounting Dimensions.

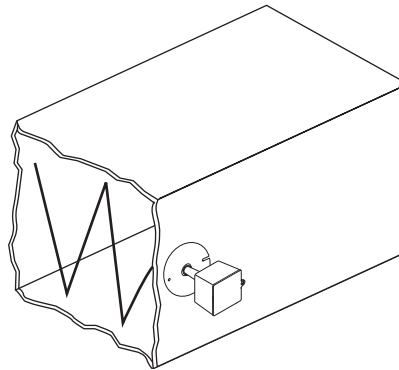

Figure-15 TS-9405/9422 Typical Mounting.

TS-8501 Outdoor Air Sensor

Mount sensor to waterproof conduit box using the 1/2" conduit connection (see Figures 17 and 18).

Use optional shield if required by application (see Figure 19).

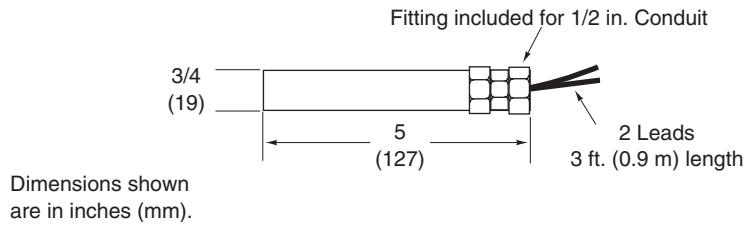

Figure-16 TS-8501 Mounting Dimensions.

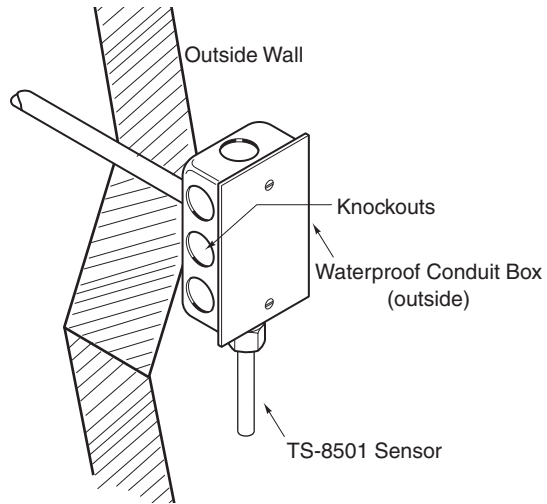

Figure-17 TS-8501 Typical Mounting.

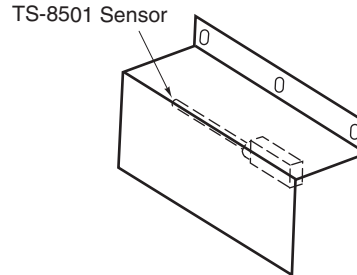

Figure-18 TS-8501 Mounted with Shield.

Mounting Duct Sensor Using Existing Mounting Plate

Table-3 APPLICABLE MODELS.

New Part Number	Old Part Number
TS-9201	TS-8201
TS-9201-106	TS-8201-106
TS-9405	TS-8405
TS-9422	TS-8422

When a duct sensor is being replaced at a location where an existing mounting hole size exceeds the coverage of the adaptor flange, use the existing mounting plate as follows:

1. Remove the existing unit from the duct. Note location of the unit's conduit hole.
2. Remove (and set aside for later use) the conduit nut securing the mounting plate to the sensor.
3. Remove the mounting plate from the old sensor.
4. Place the mounting plate on the new sensor and secure with the conduit nut removed from the old sensor. Do not include the plastic adaptor flange.
5. When mounting the sensor to the duct, be sure the conduit hole is located appropriately.

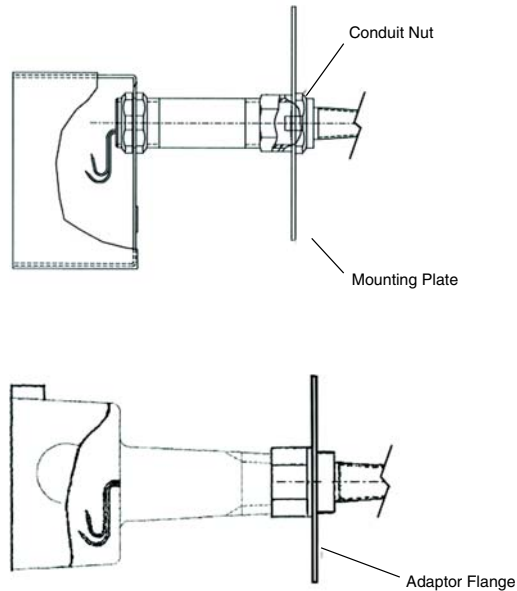

Figure-19 Mounting Duct Sensor Using Existing Mounting Plate.

WIRING

Two separate twisted pair wires (six turns per foot). Class II, low voltage, are suitable for the sensor leads except as stated below.

Caution: Shielded cable must be used when it is necessary to install the sensor lead in the same conduit with power wiring, or when it is known that high RFI/EMI generating devices are near. System ground the shield at the controller only on the COM (-) terminal or blue (-) lead. Do not use an earth ground. Do not use the enclosure as a junction box for other control circuits.

It is generally advisable to use flexible conduit to connect enclosure to rigid conduit.

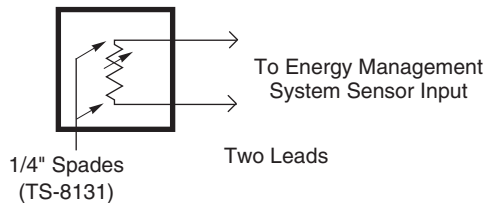

Figure-20 Sensor Connections.

Restrict element lead to shortest length practical (see Table-4).

Table-4 SENSOR WIRING LENGTHS.

Wire Gauge	Length of Run - ft. (m)	
	TS-8xxx and TS-9xxx Sensor to Controller (except TP-810x)	TS-8xxx and TS-9xxx Sensor to TP-810x
22	-	125 (38)
18	1000 (305)	300 (91)
16	2250 (686)	-
14	4000 (1219)	-

Table-5 TS-8000 & TS-9000 SERIES BALCO TEMPERATURE SENSORS.

T=F	R=Ohms	T=F	R=Ohms	T=F	R=Ohms	T=F	R=Ohms	T=F	R=Ohms	T=F	R=Ohms
-50	760.8	0	854.8	50	956.9	100	1067.0	150	1185.2	200	1311.4

Table-5 TS-8000 & TS-9000 SERIES BALCO TEMPERATURE SENSORS.

T=F	R=Ohms	T=F	R=Ohms	T=F	R=Ohms	T=F	R=Ohms	T=F	R=Ohms	T=F	R=Ohms
-49	762.6	1	856.8	51	959.0	101	1069.3	151	1187.7	201	1314
-48	764.4	2	858.8	52	961.2	102	1071.6	152	1190.1	202	1316.7
-47	766.2	3	860.7	53	963.3	103	1073.9	153	1192.6	203	1319.3
-46	768.0	4	862.7	54	965.4	104	1076.2	154	1195.0	204	1321.9
-45	769.9	5	864.7	55	967.6	105	1078.5	155	1197.5	205	1324.5
-44	771.7	6	866.7	56	969.7	106	1080.8	156	1199.9	206	1327.1
-43	773.5	7	868.6	57	971.8	107	1083.1	157	1202.4	207	1329.1
-42	775.3	8	870.6	58	974.0	108	1085.4	158	1204.9	208	1332.4
-41	777.1	9	872.6	59	976.1	109	1087.7	159	1207.3	209	1335.0
-40	779.0	10	874.6	60	978.3	110	1090.0	160	1209.5	210	1337.7
-39	780.8	11	876.6	61	980.5	111	1092.3	161	1212.3	211	1340.3
-38	782.6	12	878.6	62	982.6	112	1094.7	162	1214.8	212	1342.9
-37	784.5	13	880.6	63	984.8	113	1097.0	163	1217.3	213	1345.6
-36	786.3	14	882.6	64	986.9	114	1099.3	164	1219.7	214	1348.2
-35	788.2	15	884.6	65	989.1	115	1101.6	165	1222.2	215	1350.9
-34	790.0	16	886.6	66	991.3	116	1104.0	166	1224.7	216	1353.5
-33	791.9	17	888.6	67	993.5	117	1106.3	167	1227.2	217	1356.2
-32	793.7	18	890.7	68	995.6	118	1108.7	168	1229.7	218	1358.9
-31	795.6	19	892.7	69	997.8	119	1111.0	169	1232.2	219	1361.5
-30	797.5	20	894.7	70	1000.0	120	1113.3	170	1234.7	220	1364.2
-29	799.3	21	896.7	71	1002.2	121	1115.7	171	1237.2	221	1366.9
-28	801.2	22	898.8	72	1004.4	122	1118.0	172	1239.3	222	1369.5
-27	803.1	23	900.8	73	1006.6	123	1120.4	173	1242.3	223	1372.2
-26	804.9	24	902.8	74	1008.8	124	1122.5	174	1244.8	224	1374.9
-25	806.8	25	904.9	75	1011.0	125	1125.1	175	1247.3	225	1377.6
-24	808.7	26	906.9	76	1013.2	126	1127.5	176	1249.8	226	1380.3
-23	810.6	27	909.0	77	1015.4	127	1129.9	177	1252.4	227	1382.9
-22	812.5	28	911.0	78	1017.6	128	1132.2	178	1254.9	228	1385.6
-21	814.4	29	913.1	79	1019.8	129	1134.6	179	1257.4	229	1388.3
-20	816.3	30	915.1	80	1022.0	130	1137.0	180	1260.0	230	1391.0
-19	818.2	31	917.2	81	1024.2	131	1139.4	181	1262.5	231	1393.7
-18	820.1	32	919.2	82	1026.5	132	1141.7	182	1265.1	232	1396.4
-17	822.0	33	921.3	83	1028.7	133	1144.1	183	1267.6	233	1399.2
-16	823.9	34	923.4	84	1030.9	134	1146.5	184	1270.2	234	1401.9
-15	825.8	35	925.4	85	1033.2	135	1148.9	185	1272.7	235	1404.6
-14	827.7	36	927.5	86	1035.4	136	1151.3	186	1275.3	236	1407.3
-13	829.6	37	929.6	87	1037.6	137	1153.7	187	1277.8	237	1410.0
-12	831.5	38	931.7	88	1039.9	138	1156.1	188	1280.4	238	1412.8
-11	833.5	39	933.8	89	1042.1	139	1158.5	189	1283.0	239	1415.5
-10	835.4	40	935.9	90	1044.4	140	1160.9	190	1285.6	240	1418.2
-9	837.3	41	937.9	91	1046.6	141	1163.4	191	1288.1	241	1421.0
-8	839.3	42	940.0	92	1048.9	142	1165.8	192	1290.7	242	1423.7
-7	841.2	43	942.1	93	1051.1	143	1168.2	193	1293.3	243	1426.4
-6	843.1	44	944.2	94	1053.4	144	1170.6	194	1295.9	244	1429.2
-5	845.1	45	946.3	95	1055.7	145	1173.0	195	1298.5	245	1431.9
-4	847.0	46	948.5	96	1057.9	146	1175.5	196	1301.0	246	1434.7
-3	849.0	47	950.6	97	1060.2	147	1177.9	197	1303.6	247	1437.4
-2	850.9	48	952.7	98	1062.5	148	1180.3	198	1306.2	248	1440.2
-1	852.9	49	954.8	99	1064.8	149	1182.8	199	1308.8	249	1443.0
0	854.8	50	956.9	100	1067.0	150	1185.2	200	1311.4	250	1445.7

Table Data:

1. Material: Balco wire calibrated for 1000 ohms ± 1% at 70 °F.
2. Temperature coefficient: 4300 (± 150) ppm °C between 25 and 100°C.
3. Relationships:
 $R \text{ (resistance)} = 0.00161T^2 + 1.961T + 854.841$
 $\text{Temperature} = (\text{SQRT}((.00644 \times R) - 1.6597) - 1.961) / .00322$

4. Storage Temperature Specification:
Minimum = -40 °F
Maximum = 160 °F
5. Operation Temperature Specification:
Minimum = -40 °F
Maximum = 240 °F

Table Notes:

1. Temperature (T) in °F
2. Resistance (R) in ohms
3. Temperature coefficient is positive

MAINTENANCE

Regular maintenance of the total system is needed to assure sustained optimum performance. Sensors should be periodically inspected for dirt or blockage of air over the elements.

FIELD REPAIR

These sensors are not field repairable.

On October 1st, 2009, TAC became the Buildings business of its parent company Schneider Electric. This document reflects the visual identity of Schneider Electric, however there remains references to TAC as a corporate brand in the body copy. As each document is updated, the body copy will be changed to reflect appropriate corporate brand changes.

Copyright 2010, Schneider Electric
All brand names, trademarks and registered trademarks are the property of their respective owners. Information contained within this document is subject to change without notice.

Schneider Electric
1354 Clifford Avenue
P.O. Box 2940
Loves Park, IL 61132-2940

www.schneider-electric.com/buildings

