

**Valve Linkage for Pneumatic Actuators
General Instructions****Application**

The AV-430 valve linkage is used to field assemble MK-66X1, MK-68X1, and MK-6911 actuators to applicable 1/2" to 6" two-way and three-way valve bodies.

Features

- Die cast aluminum mounting bracket
- Valve position indication is provided as a standard feature

Applicable Literature

- Environmental Controls Cross-Reference Guide, F-23638
- Environmental Controls Reference Manual, F-21683
- Environmental Controls Application Manual, F-21335
- Pneumatic Products Catalog, F-27383
- Environmental Controls Valve Selection Guide, F-26094
- EN-205 Water System Guidelines, F-26080

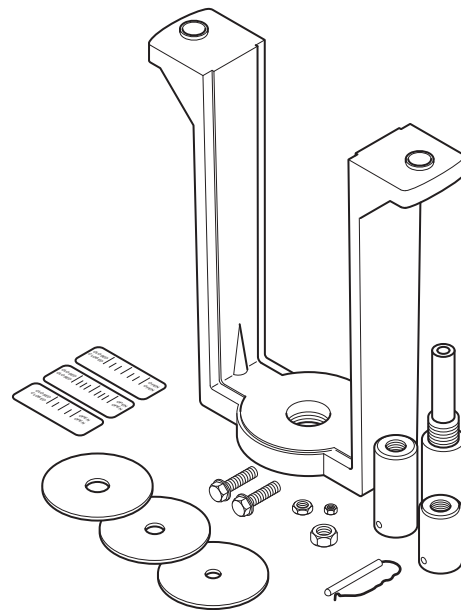

SPECIFICATIONS

Close-Off Pressure Rating

Refer to Table-1 and Table-2 to make sure the valve and actuator are compatible with each other, and that the close-off rating is adequate for the application. Refer to Table-3 and Table-4 for listings of obsolete valves and their corresponding actuators that used the AV-430 valve linkage. Verify that the valve body differential pressure is in compliance with the limitations specified for the valves being used with MM-400/500 actuators. Refer to **Environmental Controls Valve Selection Guide, F-26094** for detail information.

Table-1 Selection and Close-Off Ratings for Current VB-7XXX Valves.

VALVE BODY INFORMATION					CLOSE-OFF PRESSURE, psi (kPa) ^a									
					Actuator MK-6601			Actuator MK-6611			Actuator MK-6621			
					Stem Up	Stem Down		Stem Up	Stem Down		Stem Up	Stem Down		
15 ^b (104)	20 ^b (138)	15 ^b (104)	20 ^b (138)	15 ^b (104)		20 ^b (138)								
Valve Body Part Number	Description	Normal Position (SU)	C _v	Size	Stem Up	15 ^b (104)	20 ^b (138)	Stem Up	15 ^b (104)	20 ^b (138)	Stem Up	15 ^b (104)	20 ^b (138)	
VB-7213-0-4-10 VB-7214-0-4-10 VB-7215-0-4-10	2-Way, FNPT, Union Sweat, and R _p	Open	28	1-1/2"	—	160 (1104)	250 (1725)	—	115 (794)	230 (1587)	—	30 (207)	160 (1104)	
40			2"	—	90 (621)	160 (1104)	—	60 (414)	125 (862)	—	15 (104)	90 (621)		
VB-7223-0-4-10 VB-7224-0-4-10 VB-7225-0-4-10		Closed	28	1-1/2"	40 (276)	—	—	85 (586)	—	—	170 (1173)	—	—	
40			2"	20 (138)	—	—	50 (345)	—	—	85 (586)	—	—		
VB-7253-0-4-10		2-Way, FNPT Stainless Steel Trim & Teflon Disc	Open	28	1-1/2"	—	160 (1104)	250 (1725)	—	115 (794)	230 (1587)	—	30 (207)	160 (1104)
40				2"	—	90 (621)	160 (1104)	—	60 (414)	125 (862)	—	15 (104)	90 (621)	
VB-7263-0-4-10	Closed		28	1-1/2"	40 (276)	—	—	85 (586)	—	—	170 (1173)	—	—	
40			2"	20 (138)	—	—	50 (345)	—	—	85 (586)	—	—		
VB-7273-0-4-10	2-Way, FNPT Stainless Steel Trim	Open	28	1-1/2"	—	160 (1104)	250 (1725)	—	115 (794)	230 (1587)	—	30 (207)	160 (1104)	
40			2"	—	90 (621)	160 (1104)	—	60 (414)	125 (862)	—	15 (104)	90 (621)		
VB-7283-0-4-10		Closed	28	1-1/2"	40 (276)	—	—	85 (586)	—	—	170 (1173)	—	—	
40			2"	20 (138)	—	—	50 (345)	—	—	85 (586)	—	—		
VB-7313-0-4-10 VB-7314-0-4-10 VB-7315-0-4-10	3-Way, Mixing FNPT, Union Sweat, and R _p	Flow B to AB	28	1-1/2"	50 (345)	150 (1034)	250 (1724)	100 (689)	100 (689)	230 (1586)	180 (1241)	25 (172)	150 (1034)	
41			2"	50 (345)	150 (1034)	250 (1724)	100 (689)	100 (689)	230 (1586)	180 (1241)	25 (172)	150 (1034)		
VB-7323-0-4-10	3-Way, Diverting FNPT		28	1-1/2"	250 (1725)	250 (1725)	250 (1725)	250 (1725)	250 (1725)	250 (1725)	250 (1725)	250 (1725)	250 (1725)	
40			2"	250 (1725)	250 (1725)	250 (1725)	250 (1725)	250 (1725)	250 (1725)	250 (1725)	250 (1725)	—	250 (1725)	

^a Close-Off Pressures for 3-Way Valves are Determined as Follows:

The value for SU is the "A" port close-off pressure, and is based on the pressure at "A" port minus the pressure at "B" port.

The value for SD is the "B" port close-off pressure, and is based on the pressure at "B" port minus the pressure at "A" port.

^b Supply Air Pressure, psig (kPa).

Refer to Table-2 to make sure the valve and actuator are compatible with each other, and that the close-off rating is adequate for the application.

Table-2 Selection and Close-Off Ratings for Current VB-9XXX Valves.

VALVE BODY INFORMATION					CLOSE-OFF PRESSURE, psi (kPa) ^a												
					Actuator MK-6801			Actuator MK-6811			Actuator MK-6821			Actuator MK-6911			
					Stem Up	Stem Down		Stem Up	Stem Down		Stem Up	Stem Down		Stem Up	Stem Down		
15 ^b (104)	20 ^b (138)	15 ^b (104)	20 ^b (138)	15 ^b (104)		20 ^b (138)	15 ^b (104)		20 ^b (138)								
Valve Body Part Number	Description	Normal Position (SU)	C _v	Size	Stem Up	15 ^b (104)	20 ^b (138)	Stem Up	15 ^b (104)	20 ^b (138)	Stem Up	15 ^b (104)	20 ^b (138)	Stem Up	15 ^b (104)	20 ^b (138)	
VB-9323-0-4-12	3-Way, Diverting, 125 psi, Flanged	Flow B to AB	75	2-1/2"	125 (862)	125 (862)	125 (862)	125 (862)	125 (862)	125 (862)	125 (862)	125 (862)	125 (862)	—	—	—	
VB-9323-0-4-13			95	3"	125 (862)	125 (862)	125 (862)	125 (862)	125 (862)	125 (862)	125 (862)	125 (862)	125 (862)	—	—	—	
VB-9323-0-4-14			180	4"	—	—	—	—	—	—	—	—	—	—	125 (862)	125 (862)	125 (862)
VB-9323-0-4-15			220	5"	—	—	—	—	—	—	—	—	—	—	125 (862)	125 (862)	125 (862)
VB-9323-0-4-16			275	6"	—	—	—	—	—	—	—	—	—	—	125 (862)	125 (862)	125 (862)

^a Close-Off Pressures for 3-Way Valves are Determined as Follows:
 The value for SU is the "A" port close-off pressure, and is based on the pressure at "A" port minus the pressure at "B" port.
 The value for SD is the "B" port close-off pressure, and is based on the pressure at "B" port minus the pressure at "A" port.

^b Supply Air Pressure, psig (kPa).

Refer to Table-3 for a listing of obsolete valves and their corresponding actuators that used the AV-430 valve linkage.

Table-3 Selection and Close-Off Ratings for Obsolete Valves.

VALVE BODY INFORMATION					CLOSE-OFF PRESSURE, psi (kPa) ^a									
					Actuator MK-6801			Actuator MK-6811			Actuator MK-6821			
					Stem Up	Stem Down		Stem Up	Stem Down		Stem Up	Stem Down		
Valve Body Part Number	Description	Normal Position (SU)	C _v	Size	15 ^b (104)	20 ^b (138)	15 ^b (104)	20 ^b (138)	15 ^b (104)	20 ^b (138)	15 ^b (104)	20 ^b (138)		
VB-9213-0-4-10 VB-9214-0-4-10 VB-9215-0-4-10	2-Way, FNPT, Union Sweat, and R _p	Open	25	1-1/2"	—	160 (1104)	250 (1725)	—	115 (794)	230 (1587)	—	30 (207)	160 (1104)	
40			2"	—	90 (621)	160 (1104)	—	60 (414)	125 (862)	—	15 (104)	90 (621)		
VB-9223-0-4-10 VB-9224-0-4-10 VB-9225-0-4-10		Closed	25	1-1/2"	40 (276)	—	—	85 (586)	—	—	170 (1173)	—	—	
40			2"	20 (138)	—	—	50 (345)	—	—	85 (586)	—	—		
VB-9253-0-4-10		2-Way, FNPT Stainless Steel Trim & Teflon Disc	Open	25	1-1/2"	—	160 (1104)	250 (1725)	—	115 (794)	230 (1587)	—	30 (207)	160 (1104)
40				2"	—	90 (621)	160 (1104)	—	60 (414)	125 (862)	—	15 (104)	90 (621)	
VB-9263-0-4-10	Closed		25	1-1/2"	40 (276)	—	—	85 (586)	—	—	170 (1173)	—	—	
40			2"	20 (138)	—	—	50 (345)	—	—	85 (586)	—	—		
VB-9273-0-4-10	2-Way, FNPT Stainless Steel Trim	Open	25	1-1/2"	—	160 (1104)	250 (1725)	—	115 (794)	230 (1587)	—	30 (207)	160 (1104)	
40			2"	—	90 (621)	160 (1104)	—	60 (414)	125 (862)	—	15 (104)	90 (621)		
VB-9283-0-4-10		Closed	25	1-1/2"	40 (276)	—	—	85 (586)	—	—	170 (1173)	—	—	
40			2"	20 (138)	—	—	50 (345)	—	—	85 (586)	—	—		
VB-9313-0-4-10 VB-9314-0-4-10 VB-9315-0-4-10	3-Way, Mixing FNPT, Union Sweat, and R _p	Flow B to AB	33	1-1/2"	29 (1304)	85 (586)	160 (1104)	60 (414)	60 (414)	130 (897)	105 (724)	14 (97)	85 (586)	
VB-9313-0-4-11 VB-9314-0-4-11 VB-9315-0-4-11			55	2"	29 (1304)	85 (586)	160 (1104)	60 (414)	60 (414)	130 (897)	105 (724)	14 (97)	85 (586)	
VB-9323-0-4-10	3-Way, Diverting FNPT		30	1-1/2"	250 (1725)	250 (1725)	250 (1725)	250 (1725)	250 (1725)	250 (1725)	250 (1725)	250 (1725)	250 (1725)	
40			2"	250 (1725)	250 (1725)	250 (1725)	250 (1725)	250 (1725)	250 (1725)	250 (1725)	250 (1725)	250 (1725)		

^a Close-Off Pressures for 3-Way Valves are Determined as Follows:
The value for SU is the "A" port close-off pressure, and is based on the pressure at "A" port minus the pressure at "B" port.
The value for SD is the "B" port close-off pressure, and is based on the pressure at "B" port minus the pressure at "A" port.
^b Supply Air Pressure, psig (kPa).

Refer to Table-4 for a listing of obsolete valves and their corresponding actuators that used the AV-430 valve linkage.

Table-4 Obsolete Valves and Corresponding Actuators Using Valve Linkage AV-430.

Valve Data		Actuator Series	
Part Number Series	Sizes	MK-68X1	MK-6911
VB-202	1/2" to 2"	Yes	No
VB-202	2-1/2" to 4"	Yes	No
VB-212	1/2" to 2"	Yes	No
VB-252	1/2" to 2"	Yes	No
VB-252	2-1/2" to 4"	Yes	No
VB-304	1/2" to 2"	Yes	No
VB-304	2-1/2" to 4"	Yes	No
VB-804	1/2" to 2"	Yes	No
VB-804	2-1/2" to 4"	Yes	No
VB-807	1/2" to 2"	Yes	No
VB-817	1/2" to 2"	Yes	No
VB-817	2-1/2" to 3"	Yes	No
VB-817	4" to 6"	No	Yes

Temperature Restrictions

Verify that the temperature of the media in the valve and the ambient temperature at the actuator do not exceed the values shown in Table-5.

Table-5 Restrictions on the Maximum Ambient Temperature for the Actuators.

Maximum Temperature of Media in the Valve (Check Ratings of the Valve)	Maximum Ambient Temperature for Actuators
	MK-68X1, MK-66X1 or MK-6911
366° F (180° C)	100° F (37° C)
340° F (171° C)	100° F (37° C)
281° F (138° C)	160° F (71° C)
250° F (121° C)	220° F (104° C) ^a

^a Maximum allowable ambient temperature for the actuator.

Required Components

Factory assemblies of valve and actuator combinations are available for several of the selections listed in Table-1 and Table-2. Consult the **Pneumatic Products Catalog, F-27383** or **Environmental Controls Valve Selection Guide, F-26094** for availability. Actuator and valve combinations not available as factory assemblies must be purchased separately, along with the appropriate valve linkage kit.

INSTALLATION

Inspection

Inspect the package for damage. If damaged, notify the appropriate carrier immediately. If undamaged, open the package and inspect the device for any obvious damage. Return damaged products.

Requirements

- Parts:
 - See Table-6 for parts selection for the AV-430 valve linkage.
- Tools (not provided):
 - Appropriate wrenches for stem extensions, locknuts, packing nuts, and bracket nuts.
 - Appropriate screw driver for actuator mounting screws.
 - TOOL-37, 1-5/8" open-ended wrench with a maximum thickness of 3/16"
- Training:
 - Installer must be a qualified, experienced technician.

Caution:

- Avoid locations where excessive moisture, corrosive fumes, or vibration are present. Do not insulate above actuator mounting nut trapping moisture.
 - Install all two-way valves so that they close against the flow. An arrow on the valve body or a tag indicates the proper flow direction.
 - Always install three-way mixing valves with two inlets and one outlet.
 - Always install three-way diverting valves with one inlet and two outlets.
 - Do not install the actuator below the center line of the valve. For steam applications only, mount the actuator above the valve body at 45° from vertical.
 - When selecting a location, allow sufficient room for accessories and for servicing the actuator.
-

Mounting

1. Actuators can be mounted in any upright position above the center line of a valve body.
2. When selecting a location, allow sufficient room for accessories and for service of the product.
3. Maintain proper flow direction when installing all globe and radiator-type valves. Flow direction is indicated by an arrow on the valve body or by information on the attached tag.

Table-6 Parts Selection for the AV-430 Valve Linkage.

Valve Body Description	Required Locknut	Required Stem Extension	Required Indicator Plate	Required Scale Length
Current Valves				
1/2" to 2" (VB-7XXX)	1/4" and 1/2"	Long for 1/4" Stem	With 1/2" Diameter Hole	1/2"
Obsolete Valves				
1/2" to 1-1/4" (obsolete VB-9XXX)	1/4" and 1/2"	Long for 1/4" Stem	With 1/2" Diameter Hole	1/2"
1-1/2" to 2" (VB-202, -212, -252, -304, -804, obsolete VB-9XXX)	1/4"	Medium for 1/4" Stem	With 1/4" Diameter Hole	1"
2-1/2" to 4" (VB-202, -252, -304, -804)	3/8"	Short for 3/8" Stem	With 3/8" Diameter Hole	1"
1/2" to 3" (VB-817)	3/8"	Short for 3/8" Stem *	With 3/8" Diameter Hole	1"
2-1/2" and 3" (VB-9323)	3/8"	Short for 3/8" Stem ^a	With 3/8" Diameter Hole	1"
4" to 6" (VB-817, VB-9323)	3/8"	Short for 3/8" Stem	With 3/8" Diameter Hole	1-1/2"

^a Included with the valve body.

ASSEMBLY PROCEDURE

Install AV-430 Valve Linkage onto 1-1/2" and 2" VB-7XX3, VB-7XX4, and VB-7XX5 Valve Bodies

1. Thread the mounting bracket onto the hex head mounting nut on the valve body. See Figure-1.
2. Position the mounting bracket, then tighten the mounting nut against it, using a 1-5/8" open-ended wrench with a maximum thickness of 3/16" (TOOL-37).

Note: Install the mounting bracket in such a position as to make the wiring or piping of the actuator convenient.

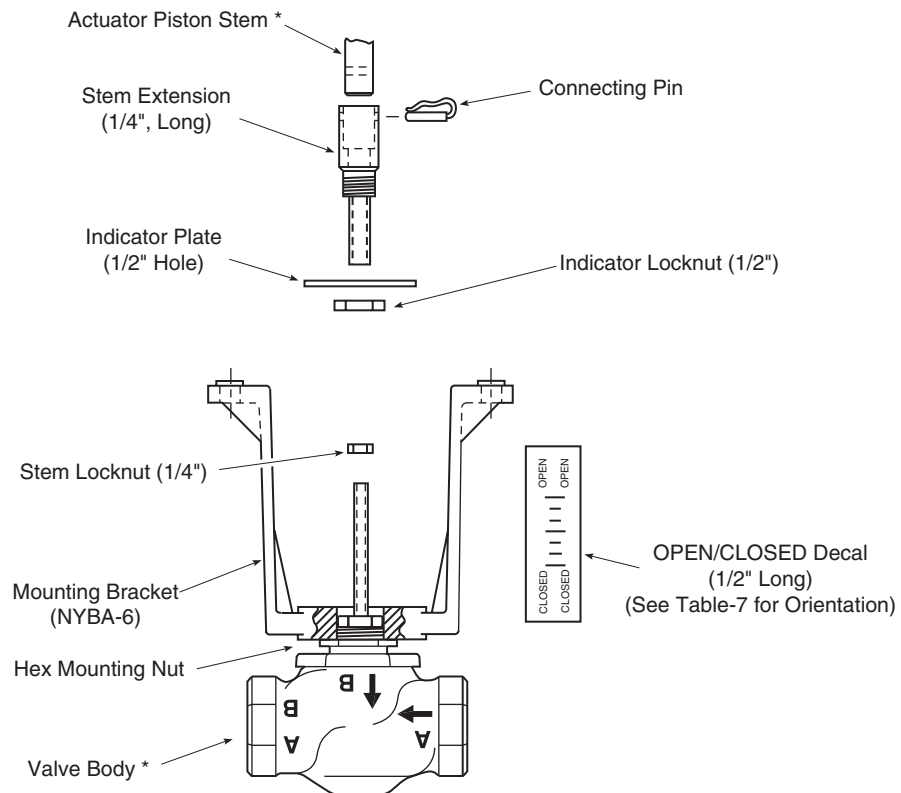

* Not included with AV-430 Linkage Kit

Figure-1 Assembly of MK-66X1 Series Actuators onto 1-1/2" and 2" VB-7XX3, VB-7XX4, and VB-7XX5 Series Valve Bodies.

3. Select the required stem extension, stem locknut, and indicator plate, according to Table-6.
4. Thread the stem locknut onto the valve stem. Continue threading the locknut until it is positioned near the bottom of the exposed valve stem.
5. Position the indicator plate onto the valve stem.
6. Thread the stem extension well down onto the valve stem.
7. Position the actuator onto the mounting bracket.
8. Secure the actuator, using the two bolts provided. For a view of the completed assembly, see Figure-2.
9. Adjust the stem height according to the instructions in the Adjustments section.
10. Tighten the stem locknut against the stem extension to secure the stem extension in position on the valve stem.

11. Apply the OPEN/CLOSED decal (which features a 1/2" scale length) onto the mounting bracket. See Table-7 for the orientation of the decal.

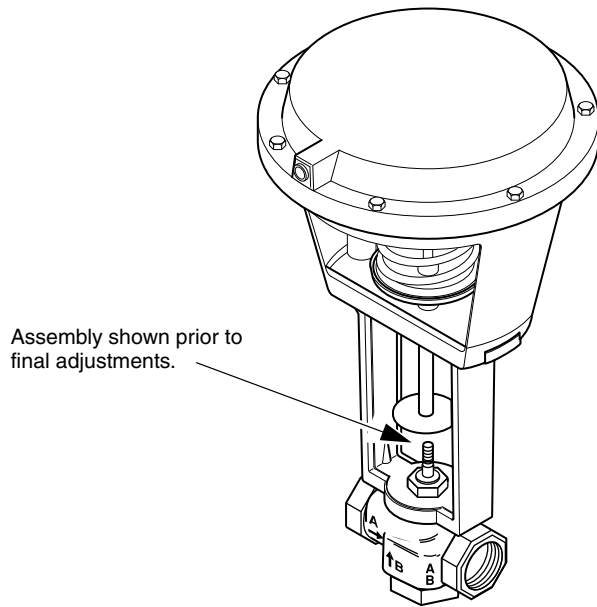

Figure-2 Typical MK-66X1 Series Actuator Using the AV-430 Valve Linkage.

Table-7 Orientation of OPEN/CLOSED Decal on Mounting Bracket.

Valve Body	Label Orientation
2-Way, Stem-Up, Open VB-721X VB-921X, VB-202, VB-212	"OPEN" End Towards Actuator
2-Way, Stem-Up, Closed VB-722X VB-922X, VB-252	"CLOSED" End Towards Actuator
3-Way, Mixing VB-731X VB-931X, VB-304, VB-804	Orientation Depends on Application: "OPEN" at Top Indicates Inlet Port "B" Is Open "OPEN" at Bottom Indicates Inlet Port "A" Is Open
3-Way, Diverting VB-7323 VB-9323, VB-817	Orientation Depends on Application: "OPEN" at Top Indicates Outlet Port "L" Is Open "OPEN" at Bottom Indicates Outlet Port "U" Is Open

Install AV-430 Valve Linkage onto Obsolete 1-1/2" and 2" VB-9XX3 and VB-9XX4 Valve Bodies

1. Install the mounting bracket onto a Style A valve body as follows:
 - a. Thread the mounting bracket onto the hex head mounting nut. See Figure-3.
 - b. Position the mounting bracket, then tighten the mounting nut against it, using a 1-5/8" open-ended wrench with a maximum thickness of 3/16" (TOOL-37).

Note: Install the mounting bracket in such a position as to make the wiring or piping of the actuator convenient.

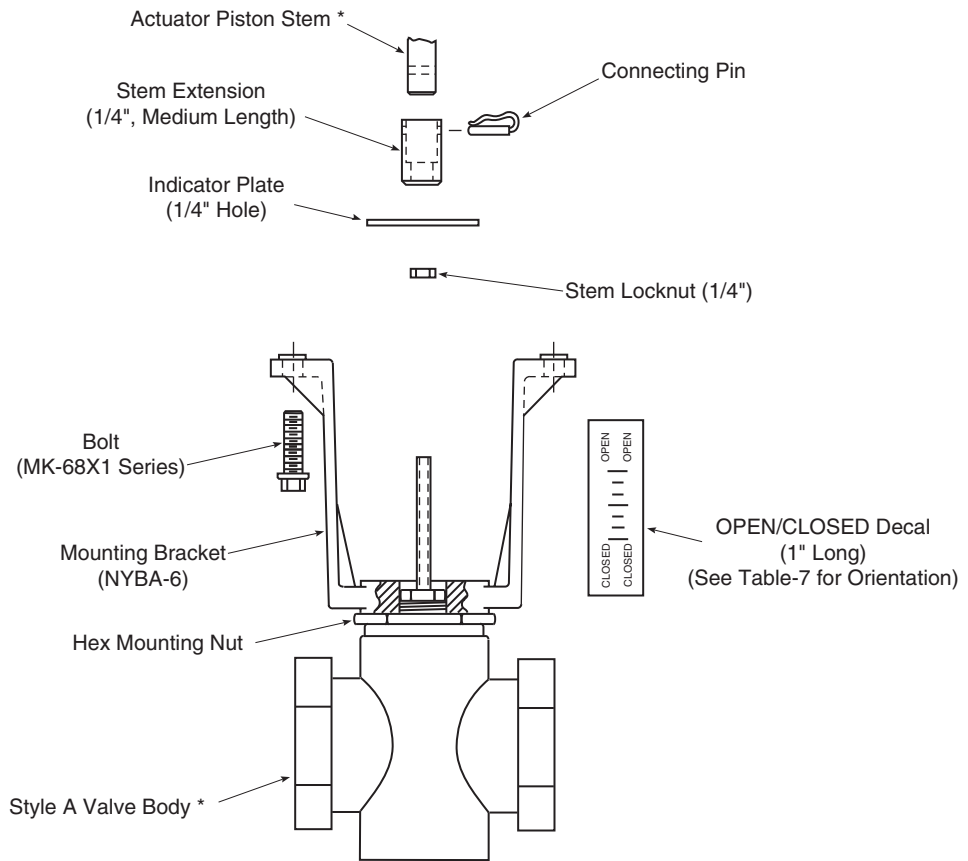

* Not included with AV-430 Linkage Kit

Figure-3 Assembly of MK-68X1 Series Actuators with Style A 1-1/2" and 2" VB-9XX3 and VB-9XX4 Series Valve Bodies.

2. Install the mounting bracket onto a Style B valve body as follows:
 - a. Remove the bracket nut from the valve body.
 - b. Position the mounting bracket onto the valve body. See Figure-4.
 - c. Replace and tighten the bracket nut onto the valve body to secure the mounting bracket.

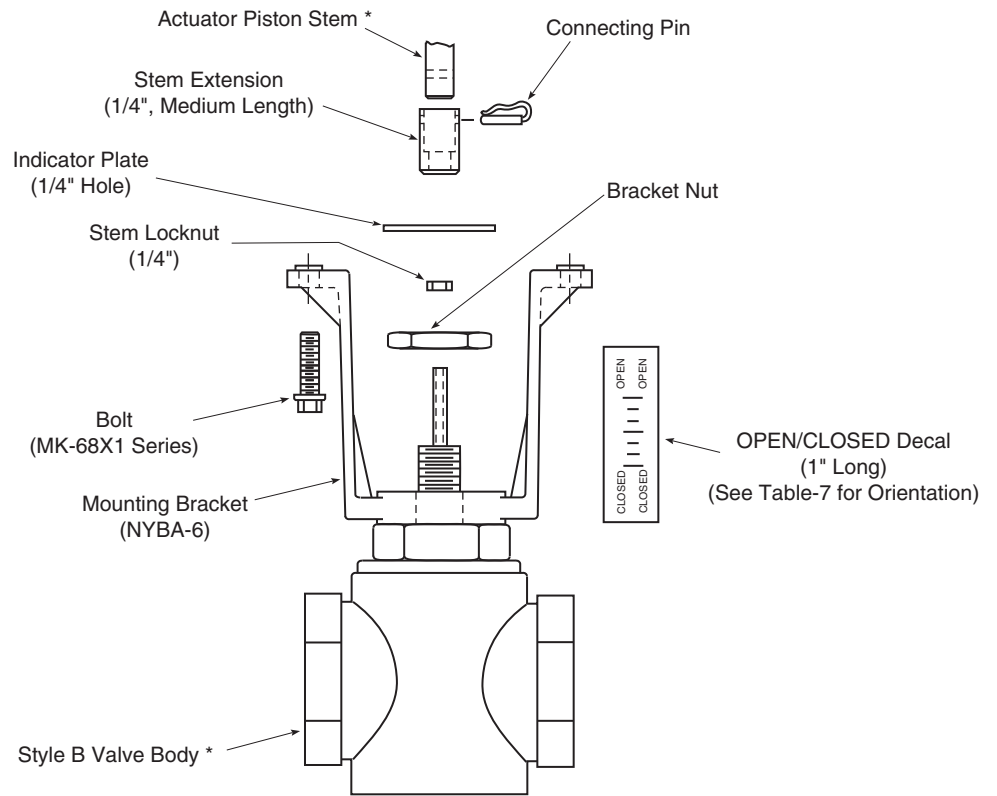

* Not included with AV-430 Linkage Kit

Figure-4 Assembly of MK-68X1 Series Actuators with Style B 1-1/2" and 2" VB-9XX3 and VB-9XX4 Series Valve Bodies.

3. Select the required stem extension, stem locknut, and indicator plate, according to Table-6.
4. Thread the stem locknut onto the valve stem. Continue threading the locknut until it is positioned near the bottom of the exposed valve stem.
5. Position the indicator plate onto the valve stem.
6. Thread the stem extension well down onto the valve stem.
7. Install the actuator onto the mounting bracket as follows:
 - MK-68X1 Series Actuators
 - a. Position the actuator onto the mounting bracket.
 - b. Secure the actuator, using the two bolts provided. For a view of the completed assembly, see Figure-5.

8. Adjust the stem height according to the instructions in the Adjustments section.
9. Tighten the stem locknut against the stem extension to secure the stem extension in position on the valve stem.
10. Apply the OPEN/CLOSED decal (which features a 1" scale length) onto the mounting bracket. See Table-7 for the orientation of the decal.

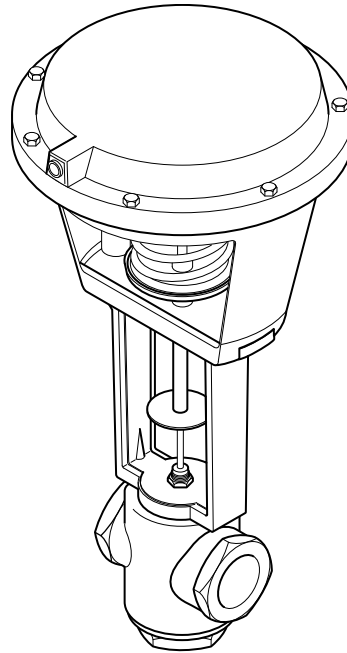

Figure-5 Typical MK-68X1 Series Actuator Using the AV-430 Valve Linkage.

Install AV-430 Valve Linkage onto VB-202, -212, -252, -304, -804, -807, and -817 (1-1/2" to 2") Valve Bodies

1. Install the mounting bracket onto the valve body as follows:
 - a. Remove the packing nut and the bracket nut from the valve body.

Note: Install the mounting bracket in such a position as to make the wiring or piping of the actuator convenient.

- b. Position the mounting bracket onto the valve body. See Figure-6.
- c. Replace and tighten the bracket nut and packing nut onto the valve body to secure the mounting bracket.

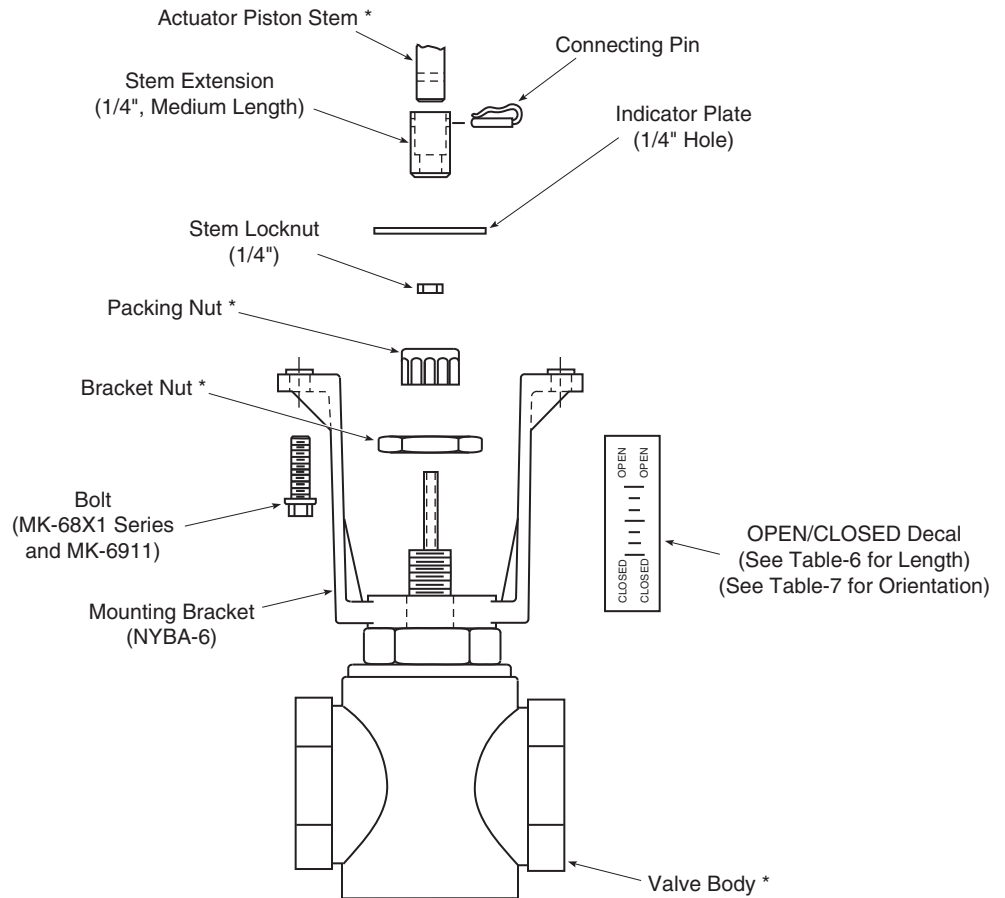

* Not included with AV-430 Linkage Kit

Figure-6 Assembly of MK-6800 Series Actuators with VB-202, -212, -252, -304, -804, -807, -817, and VB-9323 (1-1/2" to 2") Series Valve Bodies.

2. Select the required stem extension, stem locknut, and indicator plate, according to Table-6.
3. Thread the stem locknut onto the valve stem. Continue threading the locknut until it is positioned near the bottom of the exposed valve stem.
4. Position the indicator plate onto the valve stem.
5. Thread the stem extension well down onto the valve stem.

6. Install the actuator onto the mounting bracket as follows:
MK-68XX and MK-6911 Series Actuators
 - a. Position the actuator onto the mounting bracket.
 - b. Secure the actuator, using the two bolts provided. For a view of the completed assembly, see Figure-5.
7. Adjust the stem height according to the instructions in the Adjustments section.
8. Tighten the stem locknut against the stem extension to secure the stem extension in position on the valve stem.
9. Apply the OPEN/CLOSED decal onto the mounting bracket. Refer to Table-6 for the required scale length. See Table-7 for the orientation of the decal.

Install AV-430 Valve Linkage onto VB-202, -212, -252, -304, -804, -807, -817, and VB-9323 (2-1/2" to 6") Series Valve Bodies

1. Install the mounting bracket onto the valve body as follows:
 - a. Remove the packing nut and the bracket nut from the valve body.

Note: Install the mounting bracket in such a position as to make the wiring or piping of the actuator convenient.

- b. Position the mounting bracket onto the valve body. See Figure-7.
 - c. Replace and tighten the bracket nut and packing nut onto the valve body to secure the mounting bracket.
2. Select the required stem extension, stem locknut, and indicator plate, according to Table-6.
3. Thread the stem locknut onto the valve stem. Continue threading the locknut until it is positioned near the bottom of the exposed valve stem.
4. Position the indicator plate onto the valve stem.
5. Thread the stem extension well down onto the valve stem.
6. Install the actuator onto the mounting bracket as follows:
MK-68X1 Series Actuators
 - a. Position the actuator onto the mounting bracket.
 - b. Secure the actuator, using the two bolts provided. For a view of the completed assembly, see Figure-5.
7. Adjust the stem height according to the instructions in the Adjustments section.
8. Tighten the stem locknut against the stem extension to secure the stem extension in position on the valve stem.
9. Apply the OPEN/CLOSED decal onto the mounting bracket. Refer to Table-6 for the required scale length. See Table-7 for the orientation of the decal.

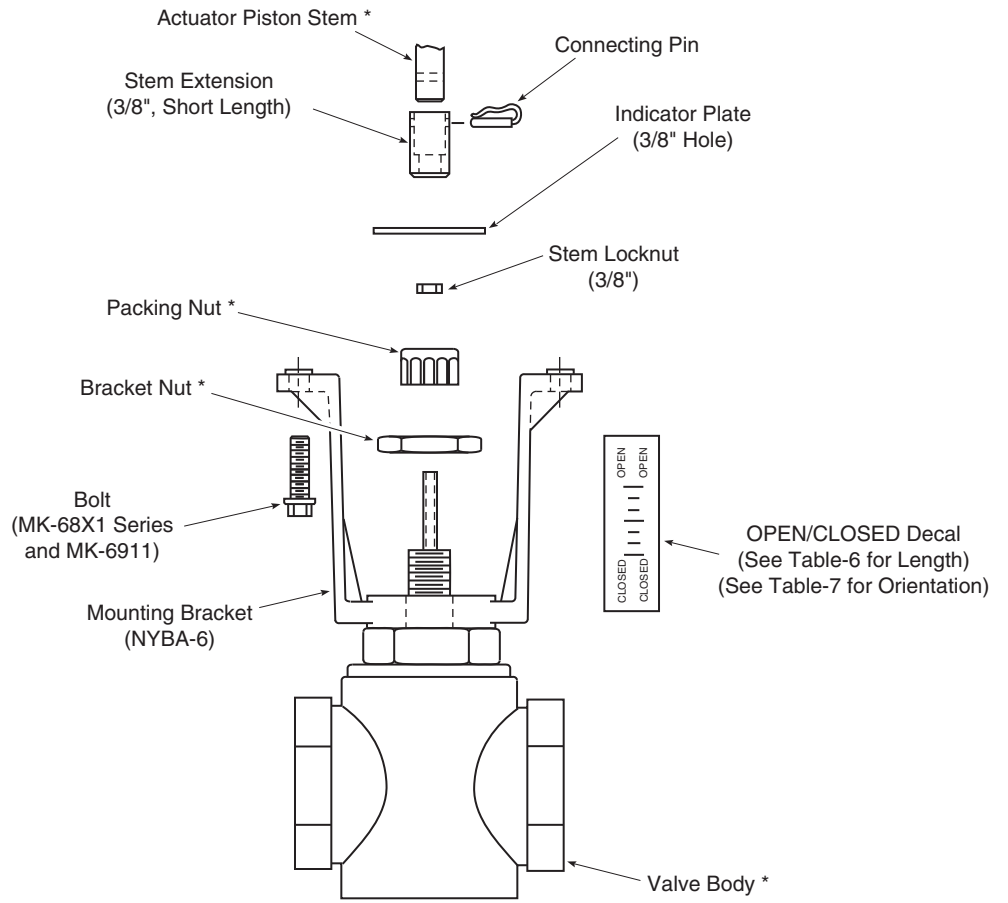

* Not included with AV-430 Linkage Kit

Figure-7 Assembly of MK-68X1, and MK-6911 Series Actuators with VB-202, -212, -252, -304, -804, -817, and VB-9323 (2-1/2" to 6") Series Valve Bodies.

Adjustments

For VB-202, VB-212, VB-7213, VB-7253, VB-7273, VB-9213, VB-9253, and VB-9273 Valve Bodies (2-Way, Normally Open)

Adjust the stem height as follows:

1. Apply supply air pressure to the actuator so that the actuator piston shaft is fully extended.
2. Push the valve stem down completely so that the valve disc is seated against the bottom valve seat.
3. Turn the stem extension only until the hole in the stem extension aligns with the hole in the actuator piston.
4. Turn the stem extension two full rotations upward, into the actuator piston.
5. Remove air pressure (actuator in the retract position) and insert the connecting pin into the aligned holes in the stem extension and actuator piston.

For VB-252, VB-304, VB-804, VB-817, VB-7223, VB-7263, VB-7283, VB-7323, VB-9223, VB-9263, VB-9283, VB-9313, and VB-9323 Valve Bodies (2-Way, Normally Closed and 3-Way)

Adjust the stem height as follows:

1. Without applying power, make sure the actuator is in the fully retracted position.
2. Make sure the valve stem is pulled completely up, so that the valve disc is seated against the top valve seat.
3. Turn the stem extension only until the hole in the stem extension aligns with the hole in the actuator piston.
4. Turn the stem extension two full rotations downward, away from the actuator piston.
5. Apply air pressure to put the actuator in the fully extended position and insert the connecting pin into the aligned holes in the stem extension and actuator piston.

For VB-7213, VB-7253, and VB-7273 Valve Bodies (2-Way, Normally Open)

Adjust the stem height as follows:

1. Without applying air, make sure the actuator is in fully retracted position.
2. Make sure the valve stem is pulled completely up (Full Open Position).
3. Turn the stem extension until the hole in the stem extension aligns with the hole in the actuator piston.
4. Insert the connecting pin into the aligned holes in the stem extension and actuator piston.

CHECKOUT

When assembly is completed, operate the actuator full-stroke several times to verify valve close-off and the performance of the assembly.

MAINTENANCE

The actuator linkage requires no maintenance.

Regular maintenance of the total system is recommended to assure sustained, optimum performance.

FIELD REPAIR

None. Replace an inoperative actuator linkage with a functional unit.

DIMENSIONAL DATA

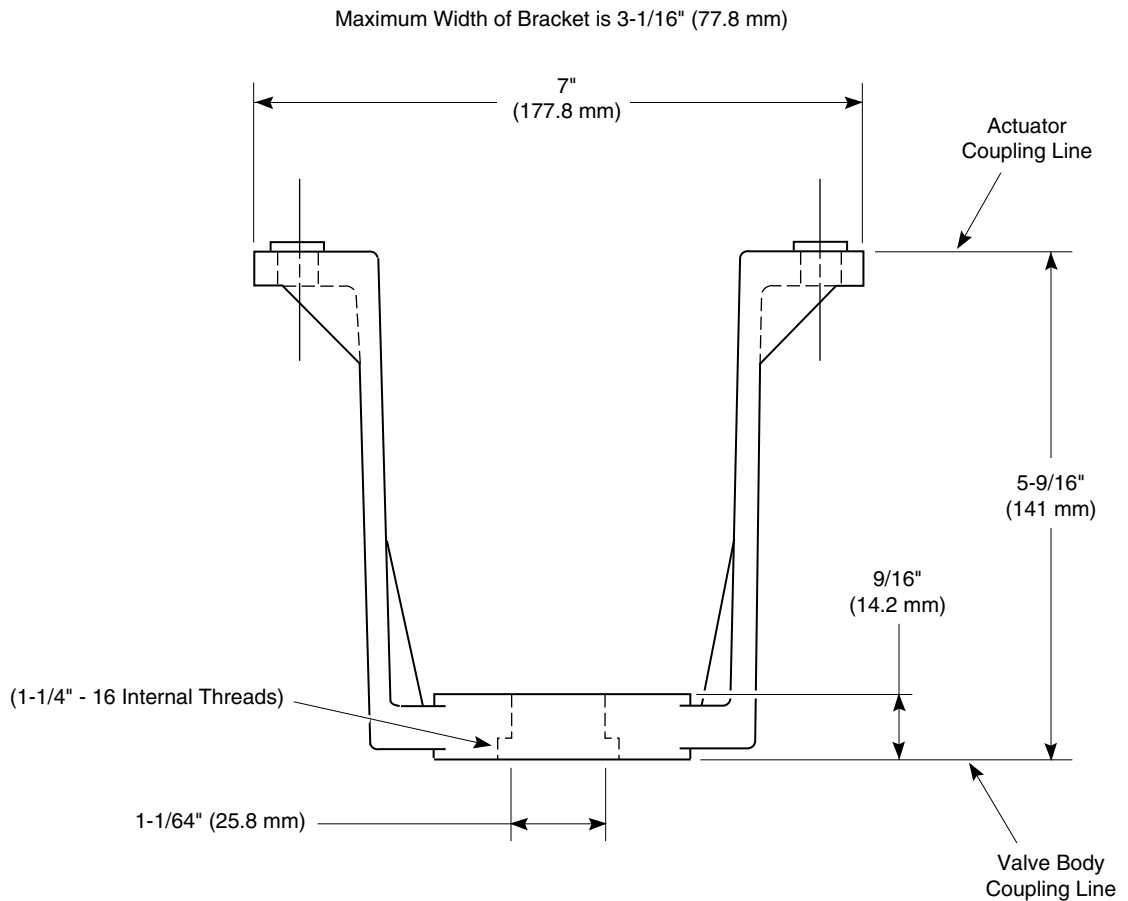

Figure-8 Dimensions of the Valve Linkage Mounting Bracket.

On October 1st, 2009, TAC became the Buildings business of its parent company Schneider Electric. This document reflects the visual identity of Schneider Electric, however there remains references to TAC as a corporate brand in the body copy. As each document is updated, the body copy will be changed to reflect appropriate corporate brand changes.

Copyright 2010, Schneider Electric
All brand names, trademarks and registered
trademarks are the property of their respective
owners. Information contained within this
document is subject to change without notice.

Schneider Electric
1354 Clifford Avenue
P.O. Box 2940
Loves Park, IL 61132-2940

www.schneider-electric.com/buildings

