

### APPLICATION

The AV-321, AV-327, AV-329 and AV-330 linkages are used to field install Schneider Electric gear train actuators to Schneider Electric valve bodies.

### ACCESSORIES

The actuators and the valve (see Table 2 for current valves and Table 3 for obsolete valves) should be purchased separately.

### CLOSE-OFF RATINGS

See Table 2 for the close-off ratings on current valves.

**TABLE 1. Restrictions On The Maximum Ambient Temperature For The Actuators**

Maximum Temperature of Media in the Valve (Check Ratings of Valve)	Maximum Ambient for Actuator
260°F (126°C)	136° F (57° C)
281°F (138°C)	125° F (52° C)
300 to 366 °F (149 to 185°C)	100° F (37° C)

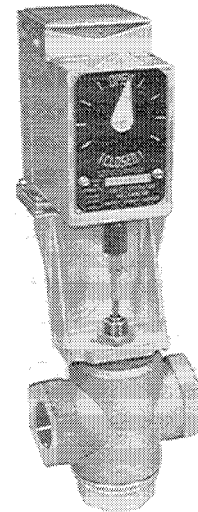

### PRE-INSTALLATION

#### Inspection

Inspect the package for damage. If damaged, notify the appropriate carrier immediately. If undamaged, open the package and inspect the device for obvious damage. Return damaged products.

#### Required Installation Items

Tools (not provided):

- Appropriate wrenches for stem extensions, lock nuts, packing nuts and bracket nuts.
- Appropriate screwdriver for actuator mounting screws.

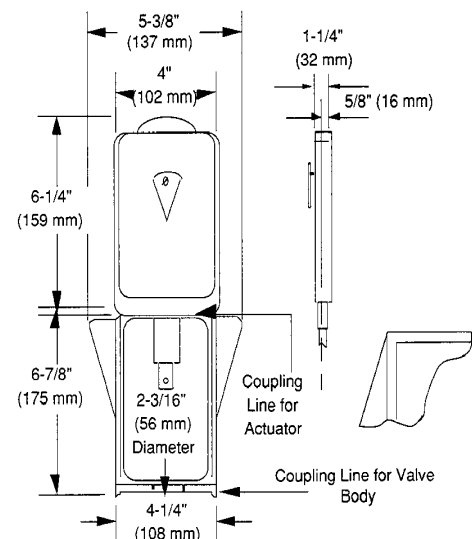

**Figure 1. Mounting Dimensions**

**TABLE 2. Linkage Selection and Valve Close-off Ratings**

				TYPICAL ACTUATOR * PART NUMBERS	TYPICAL ACTUATOR * PART NUMBERS	TYPICAL ACTUATOR ** PART NUMBERS
				NORMALLY CLOSED (STEM DOWN) MA-318, MA-318-500, MA-416 MA-416-500, MA-418, MA-418-500 MA-419, MA-419-500 MP-361, MP-461-600, MP-465 MP5-4651	NO NORMAL POSITION  MP-2150-500 MP-421 MP-422	NO NORMAL POSITION  MC-351, MC-421, MC-431 MC-4311, MC5-4311 MP-381, MP-382, MP-451 MP-452, MP-481-600, MP-485 MP-486, MP-4851, MP5-4851
				NORMALLY OPEN (STEM UP) MA-318, MA-318-500, MA-416 MA-416-500, MA-418, MA-418-500 MA-419, MA-419-500 MP-371, MP-471-600, MP-475 MP5-4751		
<b>REQUIRED LINKAGE</b>				AV-329 (AV-300 & AV-29)	AV-329 (AV-300 & AV-29)	AV-330 (AV-300 & AV-30)
<b>VALVE BODY INFORMATION</b>				CLOSE-OFF PRESSURE PSI	CLOSE-OFF PRESSURE PSI	CLOSE-OFF PRESSURE PSI
VALVE BODY PART NUMBER	DESCRIPTION	Cv	SIZE			
VB-9323-0-5-12	3-WAY, DIVERTING	"U"=68, "L"=75	2 -1/2"	125	125	125 (USE CAM MARKED "44")
VB-9323-0-5-13	125 LB. FLANGED	"U"=85, "L"=95	3"	125	125	125 (USE CAM MARKED "44")

\* Actuator must have a travel of 180° with a minimum torque of 50 lb.-in.  
 \*\* Actuator must have a travel of 180° with a minimum torque of 100 lb.-in.

**TABLE 3. Obsolete Valves Compatible with the Linkages**

Valve Body Part Number	Valve Assembly Part Numbers			Valve Sizes	Required Linkage for Actuators * with 180° Stroke and a Minimum Torque of 50 Lb.-In.			Required Linkage for Actuators # with 180° Stroke and a Minimum Torque of 100 Lb.-In.
	AV-321 or AV-300 & AV-21	AV-327 ** or AV-300 & AV-27	AV-329 or AV-300 & AV-29		AV-329 or AV-330 or AV-300 and AV-30			
DYBB-121	VA-20	VC-2004	VP-2124	1/2" to 2"	Yes	Yes	No	Yes (Use Cam Marked "39")
DYBB-123	VA-100	VC-2024	VP-3044					
OYBB-109	VA-2001	VC-2104	VP-3046					
OYBB-110	VA-2021	VC-2106	VP-8044					
OYBB-113	VA-2101	VC-2107	VS-2023					
OYBB-114	VA-2121	VC-2124	VS-8043					
OYBB-115	VA-3041	VC-3044	VU-82					
OYBB-116	VA-8041	VC-3047	VU-2024					
OYBB-119	VC-20	VC-8044	VU-2124					
OYBB-120	VC-21	VP-82	VU-3044					
VB-202-0-1-P	VC-100	VP-83	VU-8044					
VB-212-0-1-P	VC-2004	VP-100		2-1/2" to 4"	No	No	Yes	Yes (Use Cam Marked "44")
VB-804-0-1-P	VC-2006	VP-2024						
VB-807-0-1-P	VC-2007	VP-2026						
CYBC-372	VC-20	VP-82	VU-2024					
CYBC-374	VC-100	VP-100	VU-3044					
CYBC-375	VC-2004	VP-2024	VU-8044					
CYBC-406	VC-2006	VP-2026						
CYBC-408	VC-2007	VP-3044						
CYBC-409	VC-2004	VP-3046						
DYBB-140	VC-2024	VP-8044						
DYBB-142	VC-3044	VS-2023						
VB-202-0-2-P	VC-3047	VS-8043						
VB-804-0-2-P	VC-8044	VU-82						
VB-817	VA-8171	VP-8174	VU-8174	1/2" to 3"	No	No	Yes	Yes (Use Cam Marked "44")
OYBB-276	VC-2604	VS-8173		1" to 1-1/2"	Yes	No	No	Yes (Use Cam Marked "39")
VB-260								
OYBB-309	VP-2624			1/2" to 2"	Yes	No	No	Yes (Use Cam Marked "39")
VB-262								

\* Typical Actuators: MA-318, MA-318-500, MA-416, MA-416-500, MA-418, MA-418-500, MA-419, MA-419-500, MP-361, MP-361-304, MP-367  
 MP-371, MP-371-304, MP-377, MP-421, MP-422, MP-461-600, MP-461-621, MP-465, MP-465-304, MP-471-600, MP-471-621  
 MP-475, MP-475-304, MP-2110-601, MP-2110-621, MP-2150-500, MP5-2151-500, MP5-4651, MP5-4751, MU-47102  
 # Typical Actuators: MC-351, MC-421, MC-431, MC-4211, MC-4311, MC5-4311, MP-381, MP-381-304, MP-382, MP-387, MP-451, MP-452, MP-481-600,  
 MP-481-621, MP-485, MP-485-304, MP-486, MP-4851, MP5-4851, MU-48102, MU-48103, MU-48104, MU-48105, MUP-48101,  
 MUP-48102, MUP-48103, MUP-48104, MUP-48105, MUP-48106, MUP-48202, MUP-48203, MUP-48204  
 \*\* AV-327 Neutral Band Linkage closes the bottom seat of the valve approximately 40° before the CW end of actuator rotation to allow setting of  
 the auxiliary switch in the last 40° of rotation to start a DX compressor, etc.

## INSTALLATION

Verify that fluid temperature of the media in the valve versus the ambient temperature at the actuator does not exceed the ratings shown in Table 1. Refer to Tables 2 and 3 to make sure the valve, valve linkage and the actuator are compatible. See Table 2 to determine if close-off is adequate.

### CAUTION

- Installer must be a qualified, experienced technician.
- Avoid locations where excessive moisture, corrosive fumes or vibration are present.
- Install all 2-way valves so that they close against the flow. An arrow on the valve body or a tag indicates the proper flow direction.
- Always install 3-way mixing valves with two inlets and one outlet.
- Always install 3-way diverting valves with one inlet and two outlets.
- The actuators can be mounted in any position above the centerline of the valve body. For steam applications only, mount the actuator above the valve body at 45° from vertical. When selecting a location, allow sufficient room for accessories and for service of the product.

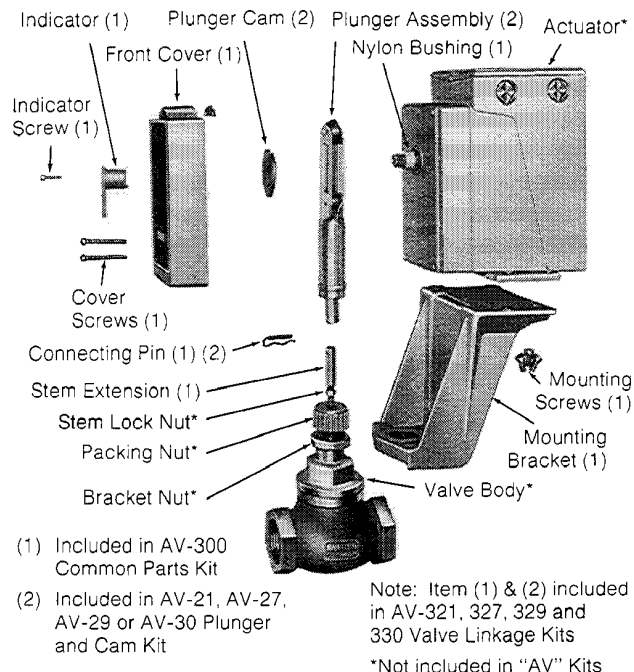

Figure-2 Assembly of AV-321, AV-327, AV-329 and AV-330 to Obsolete Valves.

### Assembly Procedure

1. Mount the bracket on the valve body by removing the packing nut and the bracket nut, placing the bracket on the valve body, and replacing and tightening the valve bracket nut and subsequently replacing the packing nut.

### NOTE

Position the bracket to a position that will make the wiring of the actuator convenient.

2. Thread stem lock nut and stem extension down fully on valve stem.
3. Place actuator on mounting bracket. Fasten actuator to mounting bracket with the three 1/4"-20 screws. DO NOT TIGHTEN SCREWS.
4. Place nylon bushing on actuator shaft.

### NOTE

MA-31X and MA-41X actuators require that a "C" ring be installed on actuator shaft before placing nylon bushing on shaft.

5. Position the actuator to the 3:00 (CW) or 9:00 (CCW) position that will have plunger cam pointing down. Use Figure 3 and Table 4 to determine if the 3:00 (CW) or 9:00 (CCW) is the correct position for plunger cam to be pointing down for the application.
6. Place the plunger cam in the plunger, and slip the plunger cam on the actuator shaft with the cam pointing down.

### NOTE

For AV-330 (AV-300 and AV-30) see Tables 2 and 3 for selection of correct cam.

7. Push the valve stem completely down against valve (lower) seat.
8. Screw stem extension until the holes the stem extension and plunger line up.
9. Turn the stem extension up (CCW) two full turns for 1/2" to 2" valves and 1-1/2 turns for 2-1/2" to 4" valves into the plunger.
10. Raise the actuator up until the connecting pin can be inserted through the holes in the plunger and stem extension.
11. Tighten the actuator mounting screws.
12. Tighten the lock nut against the stem extension.
13. Place front cover over plunger assembly and fasten to the actuator with two self-tapping screws.
14. Install the position indicator to end of the actuator shaft pointing to "Closed" (3-way valve could be pointing to "Open") and secure with screw.

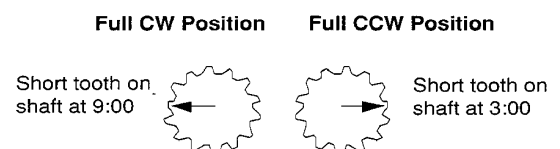

Figure 3. Actuator Shaft Position (Front View)

**TABLE 4. CAM POSITION ON ACTUATOR SHAFT**

Actuator Shaft Position	Std. Factory Positions of Cam except for Normally Closed Valves w/MA-3XX, 4XX Actuators	Opt. Cam Position used to reverse Control Action (Std. for Normally Closed Valve w/MA-3XX,4XX)
<p>CW Short tooth on actuator shaft at 9:00</p>	<p>(Cam Down)</p>	<p>(Cam Up)</p>
<p>CCW* Short tooth on actuator shaft at 3:00</p>	<p>(Cam Up)</p>	<p>(Cam Down)</p>

\*Stem down at CCW end of strokes is not available with AV-327.

**CHECKOUT**

1. Drive the actuator so that valve stem is fully up (actuator in 3:00 or 9:00 position). If the valve is a three-way, check for plunger compression (see Figure 4).
2. Drive the actuator so that valve stem is fully down (actuator in 3:00 or 9:00 position). Check for plunger compression (see Figure 5).

**Compression Check**

**NOTE**

Check the plunger spring compression (Figures 4 and 5). The length of the stem extension should be adjusted so that valve disc seats before the actuator reaches the end of the closing stroke. The balance of the actuator travel is taken up in the plunger spring compression which should be approximately 1/16" (1.6 mm). This provides pressure on the disc in the closed position(s) and also compensates for disc and seat wear. On three-way valves spring compression must be provided on both upper and lower seats.

**MAINTENANCE**

This is a quality product. Regular maintenance of the total system is recommended to assure sustained optimum performance.

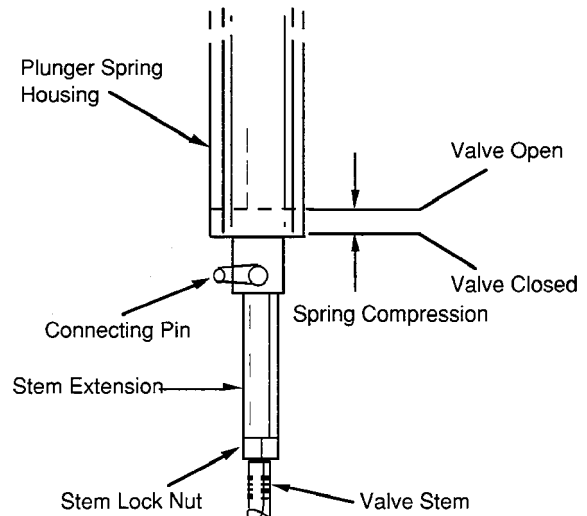

**Figure 4. Plunger Spring Compression (Valve Stem Down)**

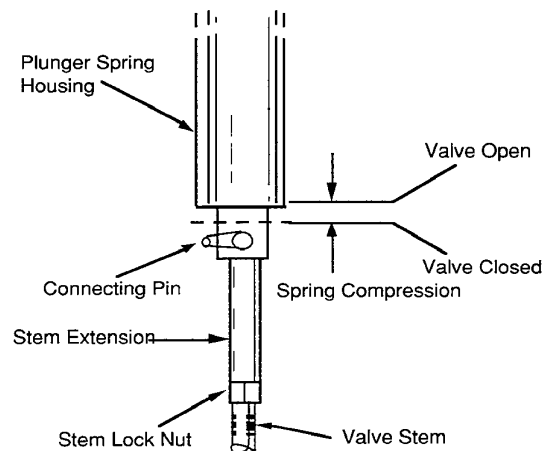

**Figure 5. Plunger Spring Compression (Valve Stem Up)**

On October 1st, 2009, TAC became the Buildings business of its parent company Schneider Electric. This document reflects the visual identity of Schneider Electric, however there remains references to TAC as a corporate brand in the body copy. As each document is updated, the body copy will be changed to reflect appropriate corporate brand changes.

Copyright 2010, Schneider Electric  
All brand names, trademarks and registered trademarks are the property of their respective owners. Information contained within this document is subject to change without notice.

**Schneider Electric**  
1354 Clifford Avenue  
P.O. Box 2940  
Loves Park, IL 61132-2940

[www.schneider-electric.com/buildings](http://www.schneider-electric.com/buildings)

