

Two-Position, Neutral Center Electric Room Thermostats General Instructions

Application

The TC-1191 series electric room thermostats, with neutral center, are used for low or line voltage On-Off control of heat/cool systems such as three- or four-pipe unitary configuration.

Features

- Anticipator available for improved performance can be used for heating or cooling.
- Auto control of heating and cooling without external switching means.
- UL and CSA models available for line voltage control.
- Night depression capability.

Applicable Literature

- TAC Environmental Controls Cross-Reference Guide F-23638
- TAC Environmental Controls Reference Manual F-21683
- TAC Environmental Controls Application Manual F-21335
- Environmental Control Systems Catalog F-16650



TC-1191



TC-1191 with Digital
Thermometer Kit Installed



TC-1191-770

†See Table-3 for agency approvals.

SPECIFICATIONS

Sensing Element: Bimetal operated snap action SPDT switch with neutral center.

Differential: 2°F (1°C) on heat, 2°F (1°C) on neutral, 2°F (1°C) on cool.

Connections: Color coded 6" leads.

Cover: Plastic as standard.

Mounting: Flush or surface switch box or directly on wall (24 Vac only).

Dimensions: 4-3/8" high x 2-7/8" wide x 1-5/8" deep (111 mm x 73 mm x 43 mm).

Table-1 Specifications.

Part Number	Company Identification	Control* Dial Range	Full Load Amps		Locked Rotor Amps		Pilot Duty (VA)
			24/120 Vac	240 Vac	24/120 Vac	240 Vac	
TC-1191	Barber-Colman	55 to 85°F	4.4, Orange to Brown Lead	2.2, Orange to Brown Lead	26.4, Orange to Brown Lead	13.2, Orange to Brown Lead	40 @ 24 Vac 210 @ 120/240 Vac
TC-1191-116		13 to 29°C					
TC-1191-500		55 to 85°F					
TC-1191-602		55 to 85°F	3.0, Orange to Red Lead	1.5, Orange to Red Lead	18, Orange to Red Lead	9, Orange to Red Lead	
TC-1191-770	55 to 85°F	Robertshaw					

*Dial stop pins included to limit dial range.

Table-2 Standard Units Include the Following.

Quantity	Description
1	Blank cover insert
1	Cover insert with setpoint dial cutout
1	5/64" Allen head screw for securing cover to thermostat base
1	5/64" Allen wrench
2	Dial stop pins to limit setpoint range

Table-3 Agency Approvals.

Configuration	Part Number	UL Listed	CSA Certified
Metal cover option	TC2-1191*	No	Yes
Plastic cover	TC-1191	Yes	No
	TC-1191-116	Yes	No
	TC-1191-770	Yes	No
Heat anticipation or night depression options	TC-1191-500	No	No
	TC-1191-602	No	No

*Only available as factory assembly. Do not convert from plastic to metal cover in the field.

Standard Cover

TC-1191

TC-1191-116

TC-1191-770

TC-1191-500

TC-1191-602

Parallel heating or cooling anticipation, 24 Vac

10°F night depression, 24 Vac



TC-1191
Standard

with



Insert



Insert

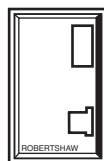

TC-1191-770
Standard

with



Insert



Insert

Options (for quantities of 24 or more each part number)

Add "dash-number" (-XXX) suffix to base part number for desired option.
For metal covers, specify TC2-1191.

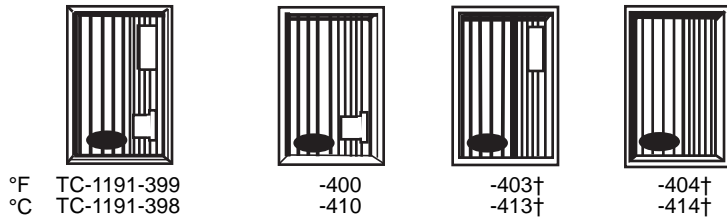

†5/64" Allen screw used to secure cover.

ACCESSORIES

- AT-61 Series Brushed bronze cover plates (TAC Barber-Colman only)
- AT-70 Series Brushed bronze cover plates (Robertshaw only)
- AT-82 °F digital thermometer cover kit (TAC Barber-Colman only)
- AT-82-116 °C digital thermometer cover kit (TAC Barber-Colman only)
- AT-82-770 °F digital thermometer cover kit (Robertshaw only)
- AT-101 Lock cover kit
- AT-504 Plaster hole cover kit (small)
- AT-505 Surface mounting base
- AT-546 Auxiliary mounting plate
- AT-602 Selector switch sub-base DP4T
- AT-603 Selector switch sub-base one DP4T, one DPDT
- AT-1100 Series Thermostat guards
- PKG-1093 Digital thermometer battery replacement kit
- TOOL-11 Calibration wrench
- TOOL-13 Contact burnishing tool

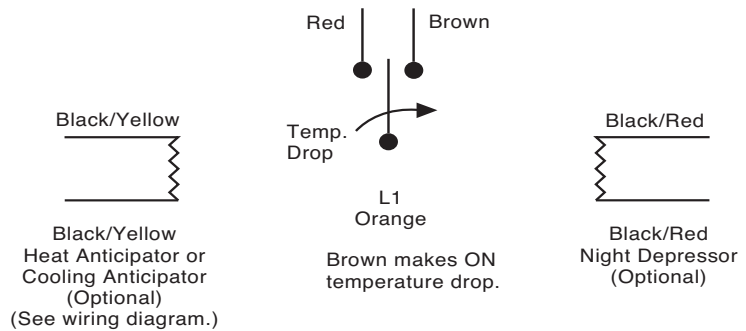

Figure-1 Switch Action and Terminal Identification.

TYPICAL APPLICATIONS

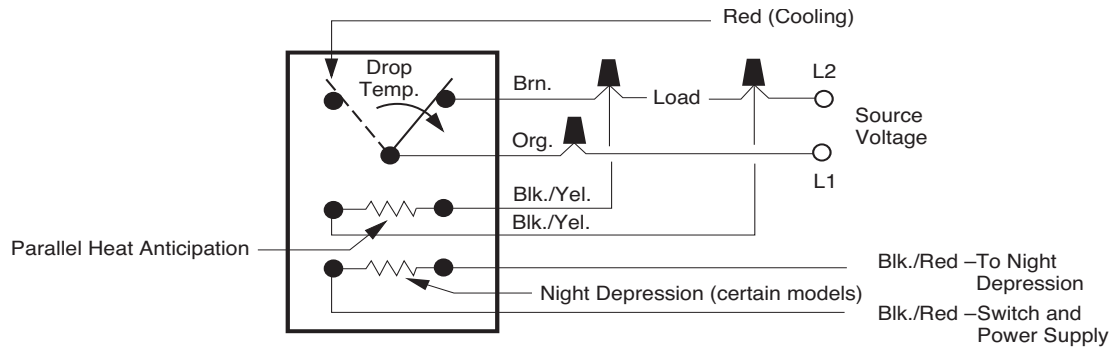

Figure-2 Typical of Parallel Heat Anticipation with or without Night Depression.
(Heater size determined by voltage.)

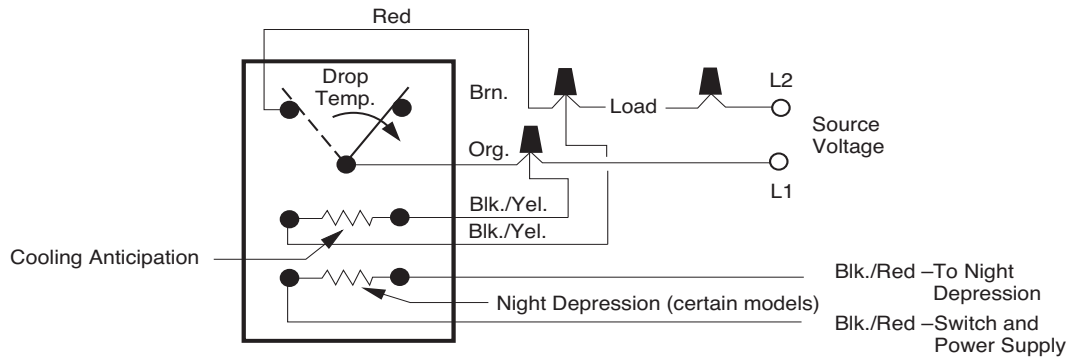

Figure-3 Typical of Cooling Anticipation with or without Night Depression.
(Heater size determined by voltage.)

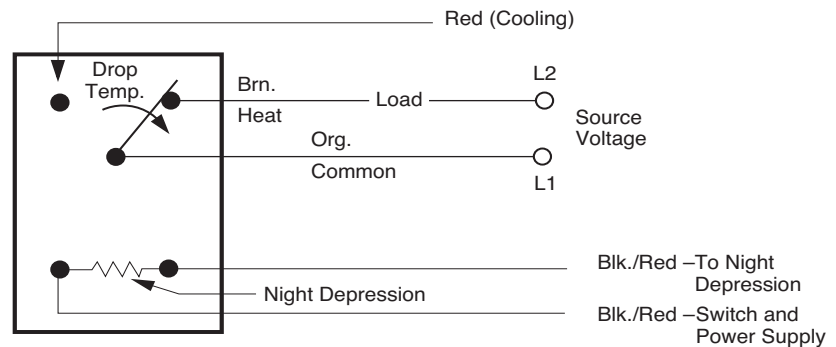

Figure-4 Typical Night Depression.

INSTALLATION

Inspection

Inspect the carton for damage. If damaged, notify the appropriate carrier immediately. Inspect the device for obvious damage. Return damaged products.

Requirements

- Job wiring diagrams
- Appropriate accessories
- Training: Installer must be a qualified, experienced technician

Warning



- Disconnect the power supply (line power) before installation to prevent equipment damage.
- Make all connections in accordance with the wiring diagram and in accordance with national and local electrical codes. Class I wiring is required unless all circuits to contacts are powered from a Class II source. *Use copper conductors only.*
- Do not locate the thermostat near sources of heat or cold such as lamps, motors, sun-

light, or concealed ducts or pipes, or where there is a danger of electrocution (i.e., shower rooms).

Caution

- Do not exceed ratings of the device(s).
- The thermostat is not designed for service in any location where condensation may occur. Avoid locations where excessive moisture, corrosive fumes, or vibration is present. NEMA Type 1 covers are intended for indoor use primarily to provide a degree of protection against contact with the enclosed equipment.
- Thermostats with guards that restrict air flow must have heating or cooling anticipation.

Mounting

The thermostat requires upright mounting on a flat vertical surface. Locate the thermostat where it is exposed to unrestricted circulation of air which represents the average temperature of the controlled space.

1. Pull all wires from source to thermostat location.
2. Make electrical connection to thermostat (see Figure-2 through Figure-4).
3. Remove thermostat cover and fasten thermostat to box or wall (see Figure-5).
4. Attach thermostat cover (see Figure-5).

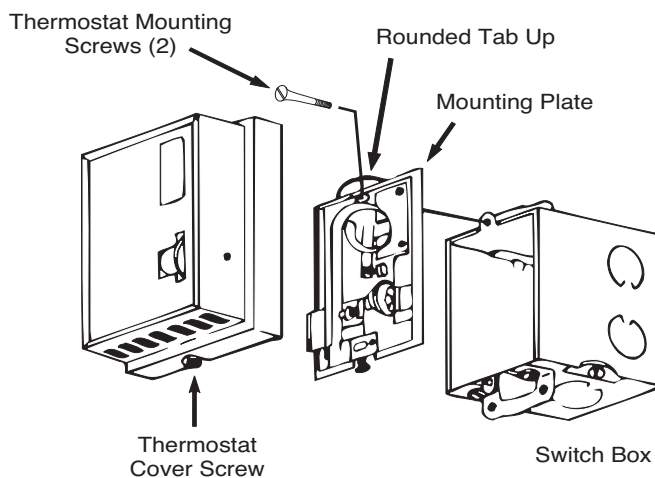

Figure-5 Thermostat Mounting.

CHECKOUT

After installing a thermostat, make an initial check of the switching action. Verify the switch action by listening to and watching the switch contacts or by using a voltmeter between the proper sides of the switch.

1. Run the setpoint dial to a temperature above ambient. This should cause the thermostat to make a circuit between the orange and brown leads.
2. Slowly turn the setpoint dial setting to a lower temperature. This breaks the circuit between the orange and brown leads. The contact blade is in a neutral position between the two contacts (not making a circuit to either contact). Turn the setpoint further down to again lower the temperature. This causes the thermostat to make a circuit between the orange and red leads.

CALIBRATION

Warning



- All thermostats are calibrated at the factory and normally do not require any such attention. However, if recalibration is necessary for any reason, proceed as follows:
 1. Turn Off control power and power to night depression circuit, where applicable.

1. Set temperature dial 2°F (1°C) below actual stable room temperature, as read from an

accurate thermometer.

- Remove cover (see Figure-5).

Caution

- Do not breathe on the thermostat or handle excessively as this affects the accuracy of the final calibration.
2. If the contact blade is made to the left (red lead) contact, use a 1/8" blade screwdriver to turn the calibration screw counterclockwise (looking at head of screw) until the blade floats between the contacts.

NOTE

Each complete turn of the screw changes calibration approximately 15°F (8°C).

3. Now turn the screw very slowly clockwise until the blade just makes the left (red lead) contact. The thermostat is now properly calibrated.
4. If the contact blade is originally made to the right (brown lead) contact or is floating between contacts, turn the calibration screw slowly clockwise until the element just makes the left (red lead) contact. The thermostat is now properly calibrated.
5. Replace the thermostat cover (see Figure-5).
6. Turn on the control power.
7. Recheck calibration about 30 minutes later to be sure heat from handling did not result in erroneous setting.

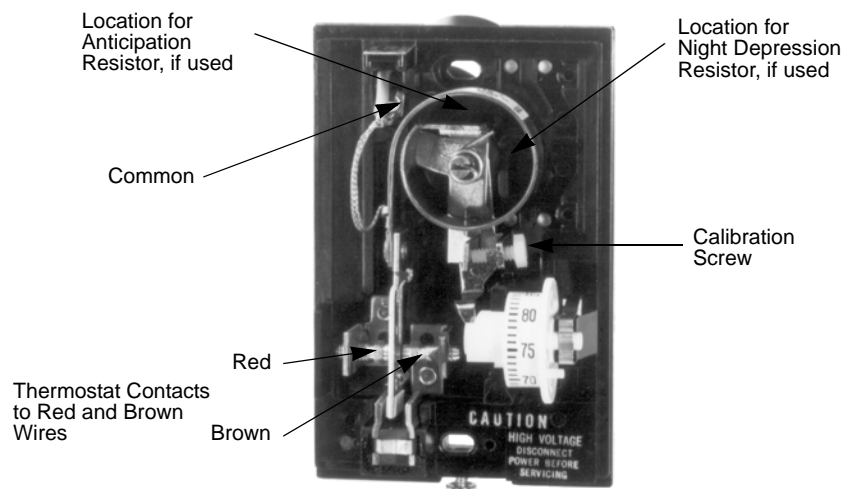

Figure-6 Part Identification.

MAINTENANCE

Warning



- Be sure that the air convection holes in the thermostat cover do not become clogged or covered. This causes improper temperature sensing.
- After long periods of continual use, it may become necessary to clean the contacts of any excess contact buildup. Before proceeding, be sure that either the electrical connections to the thermostat are disengaged or that the power to the circuit is broken. Now clean the contacts using TOOL-13 contact burnishing tool.

FIELD REPAIR

These thermostats are not field repairable. Replace entire device.

On October 1st, 2009, TAC became the Buildings business of its parent company Schneider Electric. This document reflects the visual identity of Schneider Electric, however there remains -references to TAC as a corporate brand in the body copy. As each document is updated, the body copy will be changed to reflect appropriate corporate brand changes.

Copyright 2009, Schneider Electric
All brand names, trademarks and registered
trademarks are the property of their respective
owners. Information contained within this
document is subject to change without notice.

Schneider Electric
1354 Clifford Avenue
P.O. Box 2940
Loves Park, IL 61132-2940
www.schneider-electric.com/buildings

