

Pneumatic Bulb Thermostats General Instructions

APPLICATION

For proportional temperature control of pneumatic valves and actuators to maintain air or liquid temperatures in duct, plenum chambers, liquid lines, tanks, etc. May also be used as a low limit thermostat.

SPECIFICATIONS

Thermostat: Proportional two pipe type. Thermostats are ambient compensated.

Sensing Element: Remote liquid-filled copper.

Control Dial Range: -20 to 240°F (-29 to 115°C). Shipped as -20 to 120°F, reverse side of dial 100 to 240°F.

Throttling Range: Adjustable 3 to 35°F/10 psi (2 to 19°C/69 kPa) change in output, factory set at 5°F (3°C).

Output Air Signal: 0.5 psig (3.4 kPa) to supply air pressure -0.5 (-3.4 kPa).

Action: See Table 1.

Ambient Limits:

Shipping, -40 to 150°F (-40 to 65°C). 0 to 98% R.H., non-condensing.

Case Operating, 40 to 150°F (4 to 65°C). 10 to 98% R.H., non-condensing.

Bulb, 310°F (154°C) maximum.

Supply Air Pressure: Clean, oil free, dry air required (reference EN-123).

Nominal, 20 psig (138 kPa).

Minimum, 15 psig (103 kPa).

Maximum, 30 psig (207 kPa).

Air Connections: 1/8" FNPT for main, branches and AL-362 gauges (not included).

Air Consumption for Sizing Air compressor: 0.008 scfm (3.8 ml/s).

Air Capacity for Sizing Air Mains: 16 scim (4.4 ml/s).

Mounting: Upright position on a wall or vertical flat surface.

Bulb Dimensions: See Table 1.

Capillary Length: 6' (1.8 m).

Case Dimensions: 5-13/16" high x 6-3/16" wide x 4" deep (148 mm x 157 mm x 102 mm).

ACCESSORIES

- AL-362 Stem mounted back connected 0-30 psi gauge
- AT-201 3/8" x 9-1/2" with 3/4" MNPT copper bulb well requires AT-209
- AT-203 3/8" x 9-1/2" with 3/4" MNPT stainless steel bulb well requires AT-209
- AT-206 3/8" x 4-1/2" with 1/2" MNPT copper bulb well
- AT-208 Duct mounting kit
- AT-209 Liquid line or tank mounting kit
- AT-211 Bulb shield
- AT-539 Pilot pressure kit
- TOOL-95 Pneumatic calibration tool kit (required for use as low limit thermostat)

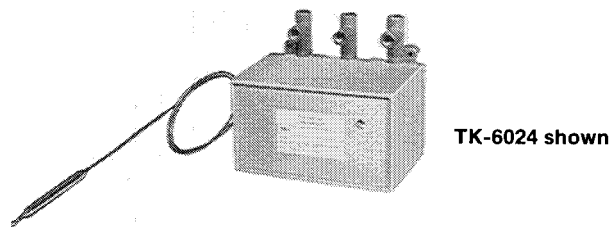

TK-6024 shown

MAINTENANCE PARTS

- AT-520-011 Relay repair kit
- AT-528 Pilot restrictor kit
- DYDK-77-031 Thermal element for TK-8X24
- DYDK-99-011 Thermal element for TK-6X24

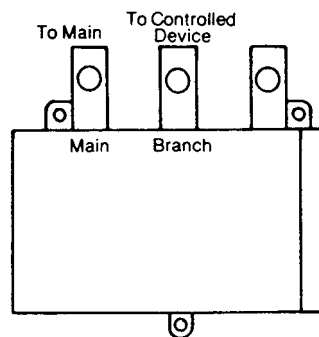

Figure-1 Piping Connections.

Table-1 Specifications.

Part Number	Action	Bulb	
		Style	Dimensions in (mm)
TK-6024	DA ^a	Straight	3/8 x 4-5/8 (9.5 x 117)
TK-8024		Averaging	3/32 x 8' (2.4 x 2.4 m)
TK-6124	RA ^a	Straight	3/8 x 4-5/8 (9.5 x 117)
TK-8124		Averaging	3/32 x 8' (2.4 x 2.4 m)

^a Direct Acting (DA) - increase output pressure on temperature rise.
Reverse Acting (RA) - Decrease output pressure on temperature rise.

PRE-INSTALLATION

Inspection

Visually inspect the carton for damage. If damaged, notify the appropriate carrier immediately. Visually inspect the device for obvious defects. Return damaged or defective products.

Required Installation Items

- Tools (not provided):
Appropriate drill, drill bits and screwdriver for mounting screws
Needle nose pliers or 3/16" open-ended wrench to hold dial shaft
- Appropriate Accessories
- Mounting screws and appropriate fittings (not provided)

INSTALLATION

Caution: Installer must be a qualified, experienced technician.

Make all connections in accordance with the job piping diagrams, local and national codes.

Avoid locations near steam or hot water coils or pipes, or wherever radiant heat will affect the bulb or capillary tube.

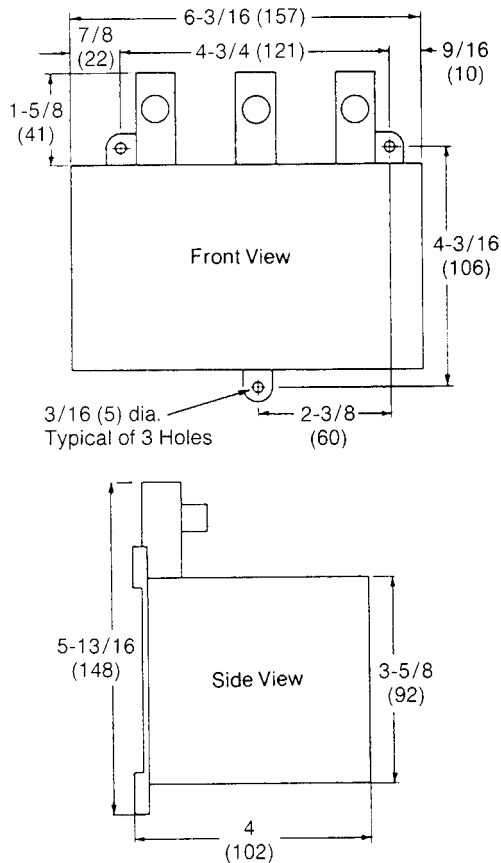

Figure-2 Mounting Dimensions.

THERMOSTAT MOUNTING

Mount the thermostat in an upright position on a wall or vertical flat surface that does not vibrate.

Three (3) mounting holes 3/16" (5 mm) provided on case.

BULB MOUNTING

Table-2 Liquid Line and Tank for TK-6X24.

Part Number	Description	Mt. Fitting	Insertion Size
AT-201 ^a	Copper bulb well	3/4" MNPT	1/2" dia. OD (9-1/2" long)
AT-203 ^a	Stainless steel bulb well		
AT-206	Copper bulb well	1/2" MNPT	1/2" dia. OD 4-1/2" long
AT-209 ^b	Bulb mounting kit	3/4" MNPT	Length of bulb

^a Requires AT-208.

^b Recommended installation is with a bulb well.

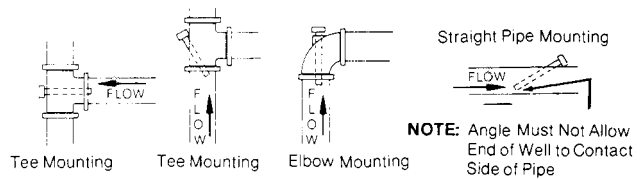

Figure-3 Bulb Well Installation.

Table-3 Application Limitations at 250°F Fluid Temp. (Max. 350°F)

Part Number	Max. Recommended Velocity (FPS)	Max. Recommended Static Pressure (psig)
AT-201	11	250
AT-203	20	500
AT-206	11	250
AT-209	4	150

Installation of TK-6X24 Bulb into AT-206 Bulb Well

1. Install AT-206 bulb well into 1/2" FNPT opening.
2. Place packing (included with AT-206) over bulb support section and insert bulb into well.
3. Push packing into nut on well using a screwdriver.

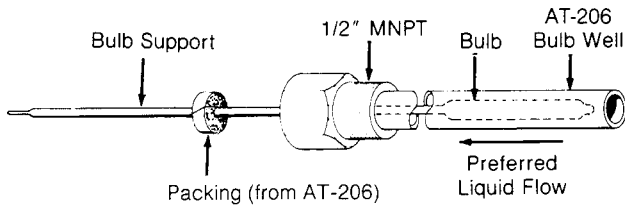

Figure-4 Installation of TK-6X24 into AT-206 Bulb Well.

Installation of TK-6X24 Bulb into AT-201 or AT-203 Bulb Well (Requires AT-209 Kit)

1. Install bulb well or adaptor from AT-209 into 3/4" FNPT opening.
2. Place packing nut, washers and packing from AT-209 over bulb support section and insert bulb into well or AT-209 adaptor.
3. Push interlocking washers and packing into well or adaptor and tighten packing nut until firmly sealed.

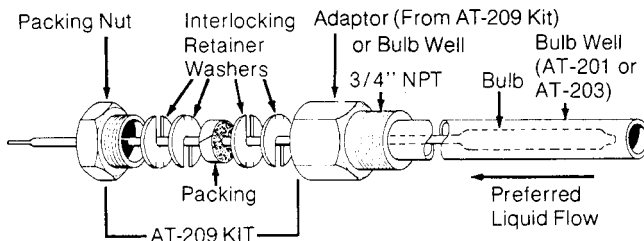

Figure-5 Installation of TK-6X24 Bulb into AT-201 or AT-203 Bulb Well with Required AT-209 Kit.

Duct Installation of TK-8X24

Install averaging bulb mounting with two AT-208 kits as shown below.

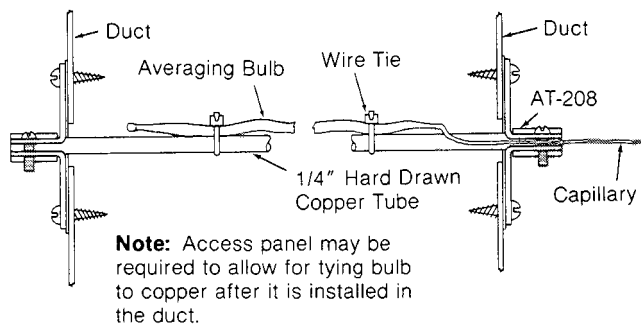

Figure-6 Installation of TK-8X24 Using AT-208 Duct Mounting Kit.

Note: Access panel may be required to allow for tying bulb to copper after it is installed in the duct.

Outdoor Installation of TK-6X24

Install with AT-211 kit as shown below.

1. Mount bulb to outside wall or surface with bulb clip.
2. Place shield over bulb and fasten to mounting surface.

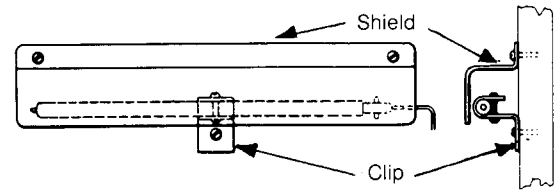

Figure-7 Installation of TK-6X24 Using AT-211 Outside Bulb Shield.

Duct Installation of TK-6X24

Install bulb with AT-208 kit as shown below.

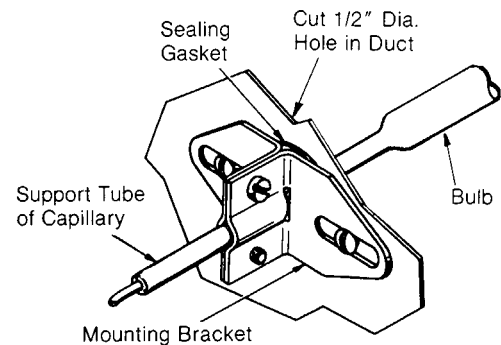

Figure-8 Installation of TK-6X24 Using AT-208 Duct Mounting Kit.

ADJUSTMENTS

Thermostats are shipped from the factory calibrated to provide an 8 psig control line pressure when the control point is equal to the setpoint.

To make all adjustments, remove the cover by first loosening the cover screws. Squeeze slightly on the top and bottom and pull forward and down, unhooking the top first.

Setpoint Dial

The thermostat has a total dial range of -20° to +240°F. One side of the dial is marked -20 to 120 and the other 100 to 240. If a setpoint higher than 120° is required, proceed as follows:

1. Rotate setpoint dial to 110°.
2. using a 3/16" open end wrench, hold hex shaft below setpoint dial.
3. Loosen screw that holds dial in place and remove.
4. Remove dial and turn over to the 100 to 240 side.
5. Start screw into dial post, before tightening line up dial at 110°, and tighten. Be sure to hold dial post with wrench when tightening screw tight.
6. Proceed with standard throttling range and calibration procedures.

Throttling Range

The throttling range should be set at the lowest value which will allow the thermostat to control the system without cycling under normal load conditions. The most satisfactory setting will vary with the type of control system. The throttling range is changed by sliding the throttling range adjustment slider to its proper position. See Figure 9. Calibration of the thermostat should be checked after the throttling range has been changed. When making the throttling range adjustment, care should be taken to prevent excessive side forces on the feedback lever. In no case should the pivot point be raised when the adjustment is made.

Throttling Range Adjustment

If the throttling range of the thermostat as shipped is not satisfactory, proceed as follows:

1. Move slider to approximate position desired (see Figure 9).
2. With instrument measuring a stable temperature, rotate setpoint dial CCW to low end of scale, then CW to that temperature "setpoint".
3. Adjust setpoint calibration screw until 3 psig (RA) or 13 psig (DA) is read on branch gauge.
4. Rotate setpoint dial CW toward upper end of scale until 13 psig (RA) or 3 psig (DA) is read on branch gauge.
5. Difference between setpoint dial readings in step 2 and 4 is the approximate mechanical throttling range of the thermostat. The thermal throttling range will be equal to or less than the mechanical throttling range.
6. If the throttling range in step 5 does not provide the control desired, move throttling range slider in appropriate direction and repeat steps 2 through 5 until desired control is obtained. If unable to obtain satisfactory control, check system for proper sizing of components being controlled and sensing element location.

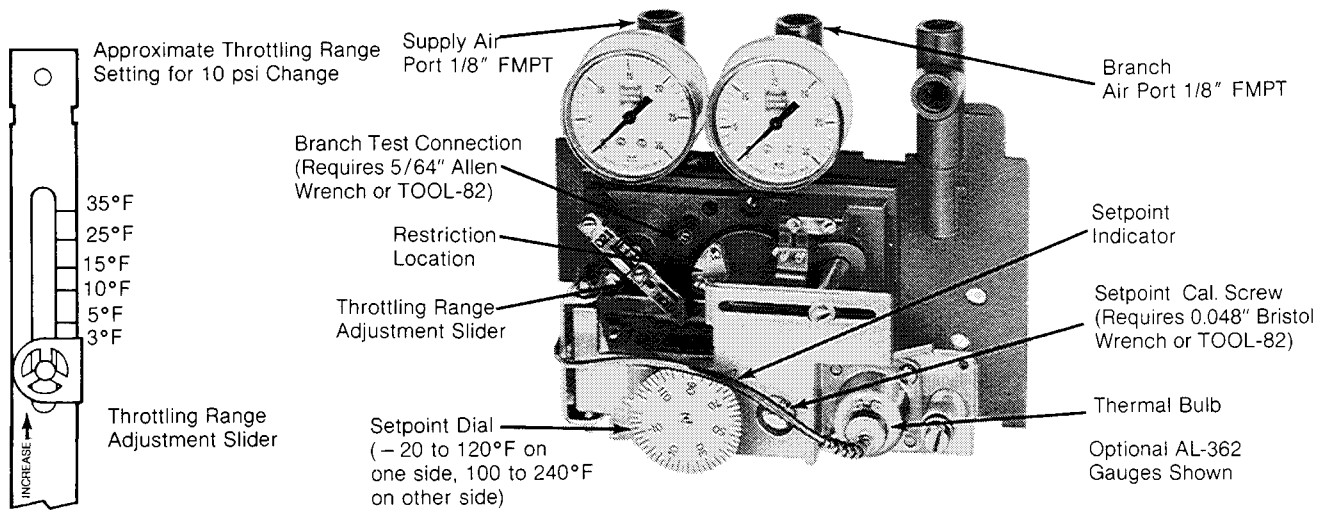

Figure-9 Thermostat Adjustments.

CALIBRATION

After the installation has been completed, the thermostat should be checked for calibration. As a nominal calibration, the controlled branch pressure should be 8 psig when the setpoint is equal to the bulb temperature, indicated by a thermometer located near the bulb. In some applications, a value other than 8 psig will be required to get the desired control results. Change the 8 psig will be required to get the desired control results. Change the 8 psig designation as used in the calibration procedure, should this be the case.

1. Using the branch gauges, or a separate test gauge connected to the branch test port (see Note), rotate the dial [direct acting (DA) - lower, reverse acting (RA) - raise] in the appropriate direction. The branch pressure should raise to be the same as the supply pressure ± 1 psi.

Note: As shown in Figure 9, each thermostat is furnished with a branch test connection. If a test gauge is to be used at this connection, use a 5/64" Allen wrench to unscrew (counterclockwise) the test point screw one full turn before attaching test gauge.

2. Measure the temperature at the bulb. This must be a stable temperature.
3. Rotate the dial to this temperature.
4. Turn the setpoint calibration screw (see Figure 9) until a branch pressure of 8 psig ± 1 psi is read on the branch gauge.

Note: The hex nut on the adjusting screw is used to provide tension only and should not be loosened when making adjustments.

5. Turn the dial to the desired setpoint.
6. If separate test gauge is used, remove gauge, tighten test point screw and replace cover.
7. Observe operation of system for satisfactory control. If necessary, recalibrate after system has come in control and stabilized.

USE AS A LOW LIMIT THERMOSTAT

These thermostats may be used as low limit thermostats. Normally in this application, they are used in series with the branch pressure of another proportional thermostat. When using two proportional thermostats in series, the second unit must have an external main air source for the pilot chamber of the thermostat. This is required to insure the operation of the second thermostat at low branch pressure from the first thermostat. An external pilot pressure kit is required for this. The part number of this kit is AT-539.

Attachment of AT-539

To attach the AT-539 external pilot pressure kit, use the following procedure.

1. Remove restriction cover plate, restriction and two gaskets (see Figure 9 for location).
2. Using the parts from the AT-539 place in order one gasket, restrictor plate, the other gasket and cover plate with the tubing attached on the restrictor mounting pad. Then install the two (2) screws.
3. Route 5/32" plastic tubing through hole in base and connect to constant 15 or 20 psig main.

Calibration When Used As Low Limit

1. Determine throttling range required. This normally is approximately 10°F.
2. Adjust branch pressure from first thermostat to maximum branch pressure.
3. Adjust throttling range as described in Throttling Range Adjustment on page 3.
4. After throttling range is adjusted, proceed with calibration of control point as described in Calibration.

FIELD SERVICE

Relay repair kit, pilot restrictor and thermal elements are available. See Maintenance Parts on page 1 for specific part numbers.

MAINTENANCE

Regular maintenance of the total system is recommended to assure sustained optimum performance.

On October 1st, 2009, TAC became the Buildings business of its parent company Schneider Electric. This document reflects the visual identity of Schneider Electric, however there remains references to TAC as a corporate brand in the body copy. As each document is updated, the body copy will be changed to reflect appropriate corporate brand changes.

Copyright 2009, Schneider Electric
All brand names, trademarks and registered trademarks are the property of their respective owners. Information contained within this document is subject to change without notice.

Schneider Electric
1354 Clifford Avenue
P.O. Box 2940
Loves Park, IL 61132-2940

www.schneider-electric.com/buildings

