

Pneumatic Damper Actuator General Instructions

GENERAL INFORMATION

For proportional pneumatic actuator with 11 sq. in. (71 cm²) effective area used to control damper and air valves in heating, ventilating and air conditioning systems

FEATURES

- Rugged cast aluminum body.
- Special linkage permits easy adjustment of stroke to suit various applications.
- Hesitation and non-hesitation models available.

Specifications

Housing: Die cast aluminum body.

Diaphragm: Replaceable beaded molded neoprene (Part number PNV-002). Factory set for 1" (25 mm).

Linkage: Adjustable 1/2 to 3" (13 to 76 mm). Factory set for 2" (51 mm).

Nominal Damper Area: Actuator sizing should be done in accordance with damper manufacturer's specifications.

Start point: Adjustable, Refer to Description Model Chart.

Spring: Retracts actuator crank arm on loss of air pressure.

Maximum Safe Air Pressure: 30 psig (207 kPa).

Ambient Temperature Limits:

Shipping, -40 to 160°F (-40 to 71°C).

Operating, -20 to 160°F (-29 to 71°C).

Air Connections: 1/8" FNPT

Mounting: In any position. Mounting bracket, linkage and connector for 5/16" (8 mm) diameter push rod assembled to actuator.

Air Connections: 1/8" FNPT.

Dimensions: 7-7/16" H x 5-3/4" W x 4-7/8" D (189 x 146 x 124 mm).

ACCESSORIES

Model No.	Description
AK-42309-500	Positive positioning relay.
AM-111	Crank arm for 5/16 in. diameter damper shaft.
AM-112	Crank arm for 3/8 in. diameter damper shaft.
AM-113	Crank arm for 1/2 in. diameter damper shaft.
AM-115	Crank arm for 7/16 in. diameter damper shaft.
AM-122	Linkage connector straight type.
AM-123	Damper clip.
AM-125	5/16 x 20 in. damper rod.
AM-125-048	5/16 x 48 in. damper rod.
AM-132	Ball joint connector.
AM-161-3	Damper linkage kit (AM-173 crank arm and AM-132 connector).
AM-743	Linkage kit for M-693 Series replacement.
TOOL-095-1	Pneumatic calibration tool kit.

Maintenance Parts

PNV-002	Diaphragm.
PNV-251	High temperature diaphragm.
PND-145-104	Black, 3 to 8 psi or 5 to 10 psi spring.
PND-145-107	Blue, 8 to 13 psi or 6 to 11 psi spring.
PND-143-083	Violet, 3 to 6 psi spring.

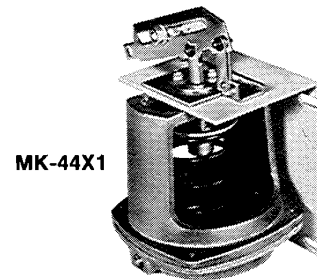

Table-1

Damper Type	Nominal Damper Area for Proportional ^a Control ^b	Nominal Damper Area for Two-Position Control MK-4421 (8-13 Spring, 20 psi Supply) ^b
Parallel Blade	4.4 sq. ft.	13.2 sq. ft.
Opposed Blade	5.6 sq. ft.	16.8 sq. ft.

^a MK-4421 requires 15 psi be available to actuator.

^b Damper ratings are nominal and based on standard (not low leakage) damper at 1" W.C. static pressure and 2000 fpm (10 m/s) velocity.

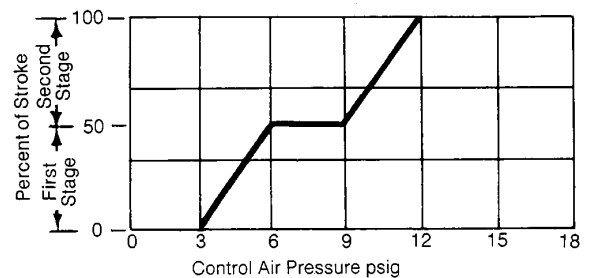

Figure-1 Relationship between Stroke and Control Air Pressure for MK-4451 Two-Stage Actuators.

INSTALLATION

Make all connections in accordance with job piping diagram. Use 1/4" OD copper or plastic tubing to connect the actuator to the controller. Units have 1/8" NPT female inlet for connection to the supply air. Actuators are mounted by means of four screws (not included) through the mounting bracket. See Figure 3 for mounting dimensions.

Insert the push rod in the actuator and damper connectors and tighten the set screws. See Figure 4 for damper linkage for 90° rotation. Apply air pressure and run the actuator through the entire stroke. Readjust linkage if binding occurs during damper shaft rotation. Readjustment may also be necessary if damper shaft does not achieve acceptable rotation.

Table-2

Part Number	Nominal Operating Range	Starting Pressure Adjustable	Maximum Force ^a				Nominal Torque ^b Proportional Control ^a		
			Return Stroke	Power Stroke			15 psi Supply Dual Press. System	15 psi Supply Single Press. System ^c	20 psi Supply Single or Dual Press. System ^c
			Based on 1.5 psi Pressure to Actuator	15 psi Supply Dual Press. System	15 psi Supply Single Press. System ^c	20 psi Supply Single or Dual Press. System ^c			
psi	psi	lb.	lb.	lb.	lb.	lb-in.	lb-in.	lb-in.	
MK-4401	3-8	3 ± 1	8.25	30.25	38.5	66	7.9	7.9	7.9
MK-4411	5-10	5 ± 1	19.25	19.25	27.5	55	7.9	7.9	7.9
MK-4421	8-13	8 ± 1	35.75	2.75	11	38.5	2.6	7.9	7.9
MK-4451	3-6, 9-12	3 to 6	8.25	8.25	16.5	44	7.9	7.9	7.9

^a Force and torques based on factory set stroke and starting pressure.
^b Nominal torque for actuators is based on 1.5 psi pressure change at the actuator..
^c Adjust pressure reducing valve so that listed pressures are available at the actuator.

ADJUSTABLE STARTING PRESSURE

The start point is the air pressure value that causes the actuator shaft to just begin to extend. If adjustment of starting pressure is required, turn adjusting nut supporting the spring clockwise to decrease and counterclockwise to increase the starting pressure, when viewing the actuator from the shaft end (Figure 3). Each rotation of the adjusting nut changes the starting pressure 0.04 psi (.28 kPa).

Note: The stroke of the MK-4451 during the first stage of operation is adjustable from 0 to 50% of total stroke.

DIAPHRAGM REPLACEMENT

If the actuator diaphragm should leak, it may easily be replaced:

1. Disconnect air line to the actuator.
2. Remove the screws on the top power housing, the top cover and the old diaphragm.
3. Insert new diaphragm over piston.

Note: Put the top power housing back in place making sure the bead on the diaphragm is in the housing groove and the screw holes are lined up.

4. Tighten the top power housing screws.

MAINTENANCE

This is a quality product. Regular maintenance of the total system is recommended to assure sustained optimum performance.

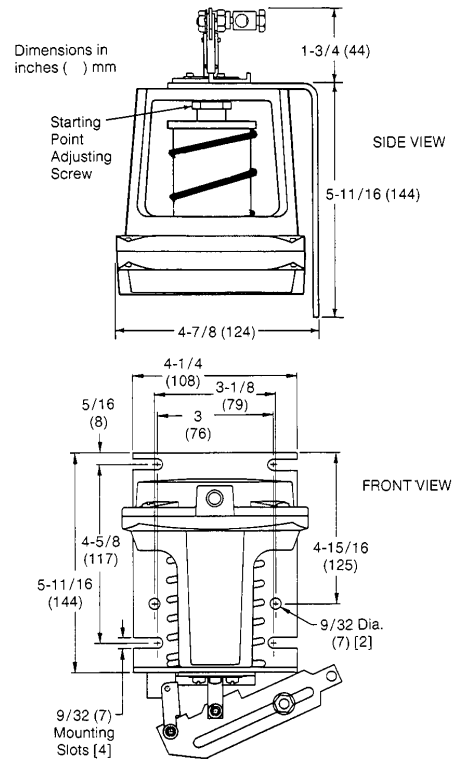

Figure-2

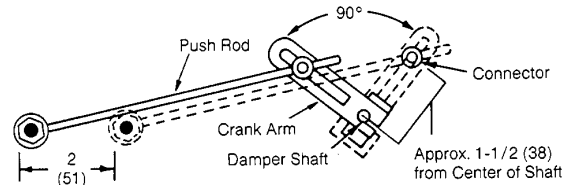

Figure-3

On October 1st, 2009, TAC became the Buildings business of its parent company Schneider Electric. This document reflects the visual identity of Schneider Electric, however there remains references to TAC as a corporate brand in the body copy. As each document is updated, the body copy will be changed to reflect appropriate corporate brand changes.