

## Concentric Vent Kit-2"

- Simplifies the installation of high efficiency furnaces
- Requires only one hole to be cut rather than two
- Saves time & money during installation

CVENT-2



# Concentric Vent Kit-2"

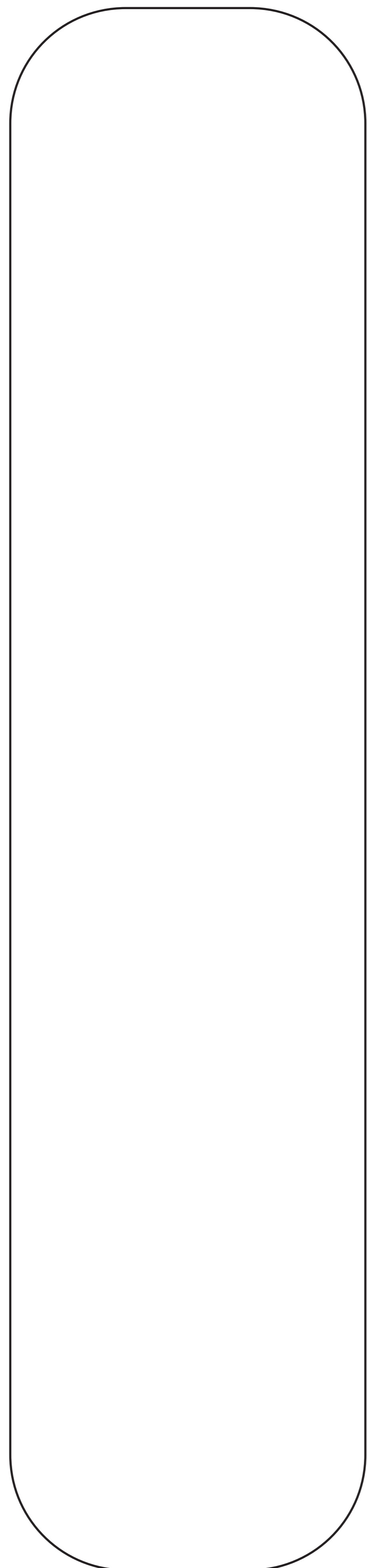

### HORIZONTAL SIDEWALL MOUNTING

NOTE: Refer to the following items before horizontal installation:

- Check furnace installation instructions for allowable clearances and locations.
- Refer to Figures 4 & 6 when venting multiple units using multiple Concentric Vents.
- Avoid locations with high winds.
- Avoid locations where Concentric Vent is likely to be damaged.
- Avoid locations where vapors are objectionable, or may damage the structure, plants or air conditioning condensing unit.

1. Use furnace installation instructions to determine pipe diameter.
2. Determine correct Concentric Vent size for the pipe diameter selected.
3. Determine the best location for the Concentric Vent.
4. When installing multiple Concentric Vents, refer to the following guidelines:
  - a. Do not install multiple Concentric Vents directly above one another unless separated by a 3" distance (minimum).
  - b. Install multiple Concentric Vents where the horizontal distance between the ends of each air intake is 4" or less or greater than 24". This will prevent a recirculation of flue gas.
5. Cut a 4" diameter hole for CVENT-2, 2" kit.
6. Partially assemble Concentric Vent kit. Follow furnace installation instructions for cleaning and cementing.
  - a. Cement "Y" fitting to larger diameter air inlet pipe (Figure 1).
  - b. Cement combustion air inlet cap to smaller diameter pipe (Figure 1).
7. Install "Y" fitting and pipe assembly through hole.
8. Install combustion air inlet cap and large diameter pipe assembly. Cement and bottom small diameter pipe in "Y" concentric fitting.
9. Secure to structure (Figure 7) using metal strapping or equivalent support material (user supplied).
10. Cement furnace combustion air and vent pipes to Concentric Vent. Refer to Figure 7 for proper pipe attachment.
11. Check installation by allowing furnace to run through one cycle.

NOTE: Keep assembly free of insulation during installation.

NOTE: Maintain clearance dimensions as shown in Figure 4, 5, 6 & 7.

NOTE: If assembly is too short, the 2 pipes supplied in the kit may be replaced by using same diameter, field supplied SDR-26 PVC (D2241) pipe. Do not extend pipes with Schedule 40 PVC or couplings. The additional wall thickness will restrict combustion air and may cause operational problems. Do not extend air inlet pipe more than 60" (Figure 7).

**CAUTION:** Do not use field supplied couplings to extend pipes.

**WARNING:** Recirculation of flue gasses may occur, causing the intake pipe to freeze shut during cold weather operation if the venting system is not installed per these guidelines. If the venting system is not installed properly, flue gas may recirculate, possibly causing the intake pipe to freeze shut during cold weather.

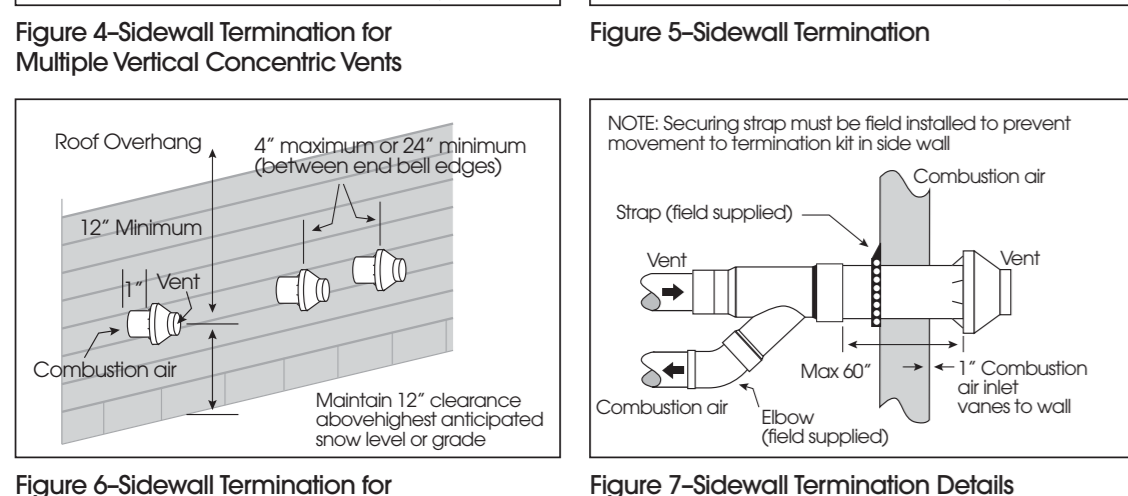
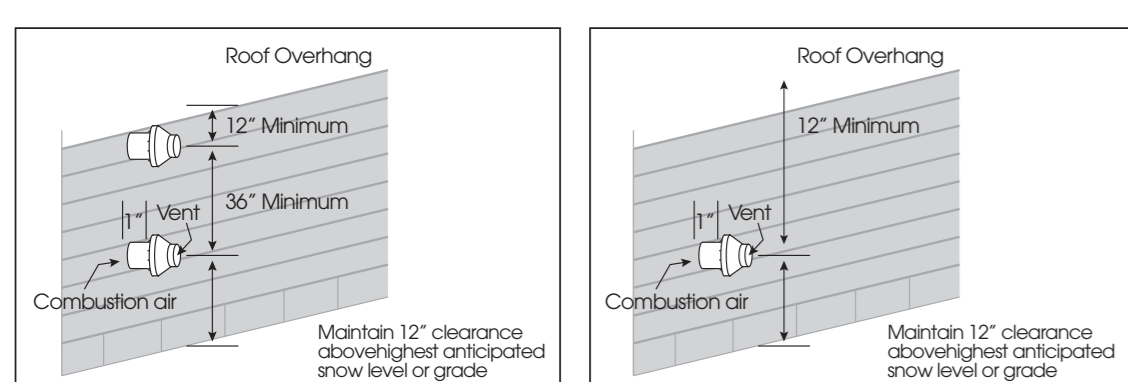
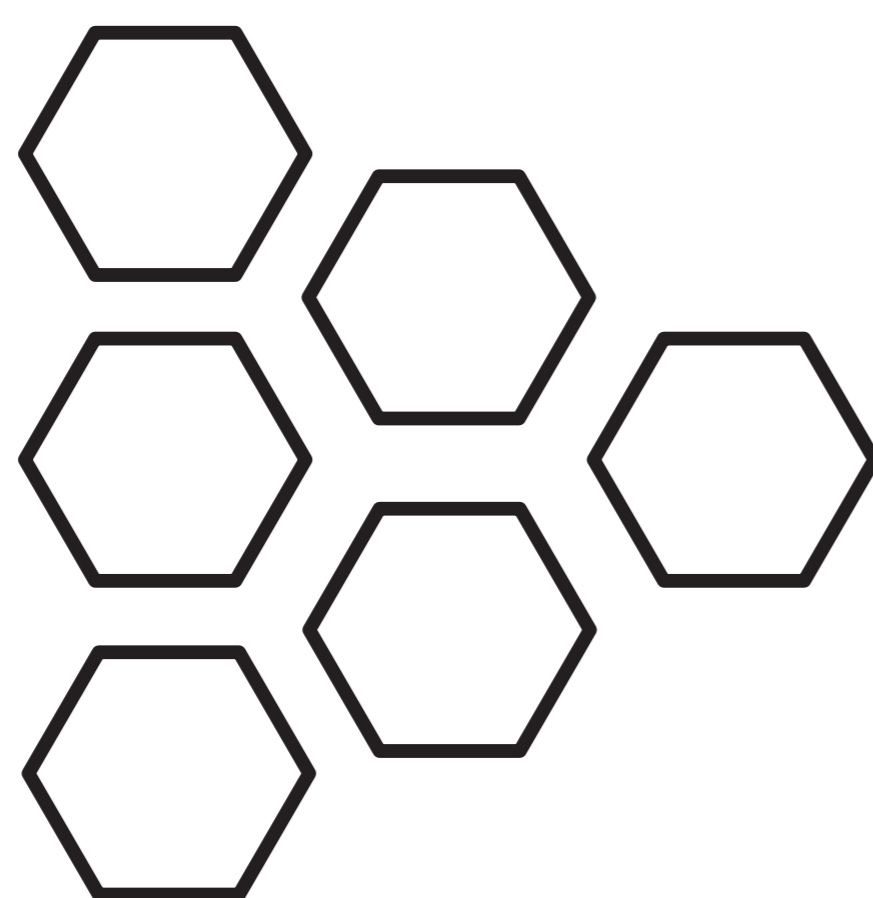

Figure 4-Sidewall Termination for Multiple Vertical Concentric Vents

Figure 5-Sidewall Termination Details



### Concentric Vent Installation Instructions

CVENT-2 Concentric Vent Termination  
For use with all condensing gas furnace models

#### General

The Concentric Vent allows both the intake for combustion air and the exhaust vent to pass through a standard roof or sidewall. This is an alternative to the standard two pipe intake/vent shown in the basic furnace installation instructions. Follow these instructions as well as the basic furnace installation instruction for installation of the intake/vent pipe(s) and all furnace installation procedures.

Refer to the furnace installation instructions for intake/vent pipe sizing information.

NOTE: The Concentric Vent reduces the allowable intake/vent piping length by 5 feet from that listed in the basic furnace installation instructions.

**WARNING:** Do not use the Concentric Vent kit for anything other than a Category IV furnace. Failure to follow this warning could result in fire, personal injury or death.

**WARNING:** Do not operate the furnace until the installation and assembly of the Concentric Vent and all piping are completed. Failure to follow this warning could result in product damage or improper operation, personal injury or death.

This kit contains the following parts:

- (1) Combustion Air Inlet Cap
- (1) Air Inlet Pipe
- (1) Vent Pipe
- (1) Intake/Vent Concentric "Y"

Pipe and fittings are required to complete installation (user supplied). The combustion air and vent pipe fittings must conform to ANSI and ASTM standards D1785, F891, D2665, D2241, D2661, or F628. Pipe cement and primer must conform to ASTM standards D2564 or D2235.

In Canada, construct all combustion air and vent pipes for this unit of CSA or ULC certified Schedule 40 PVC, PVC-DWV, or ABS-DWV pipe and pipe cement.

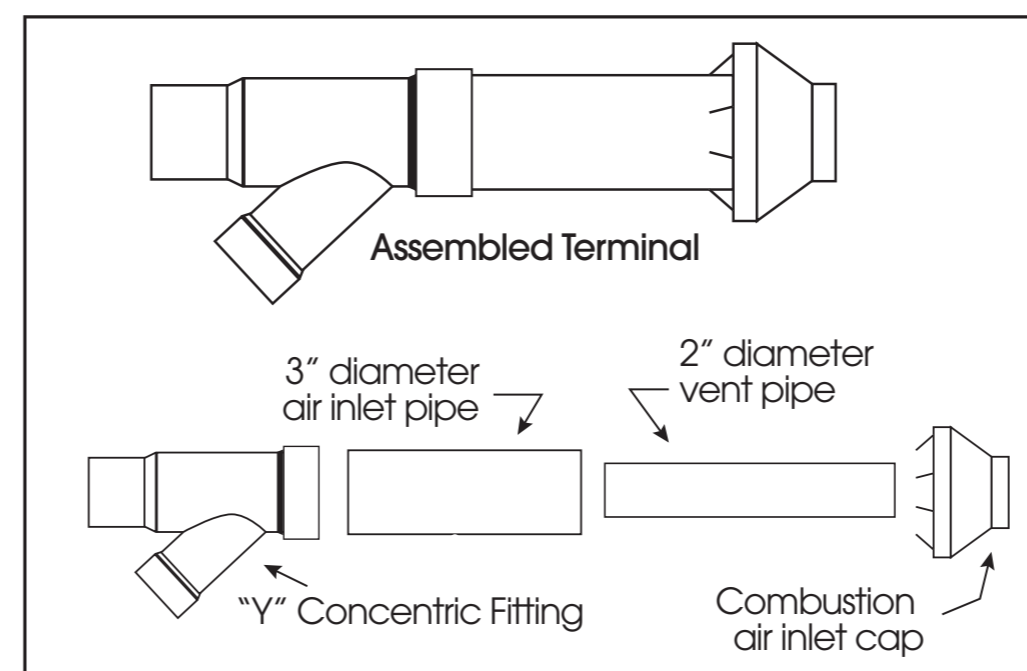

Figure 1-Vent Terminal Assembly

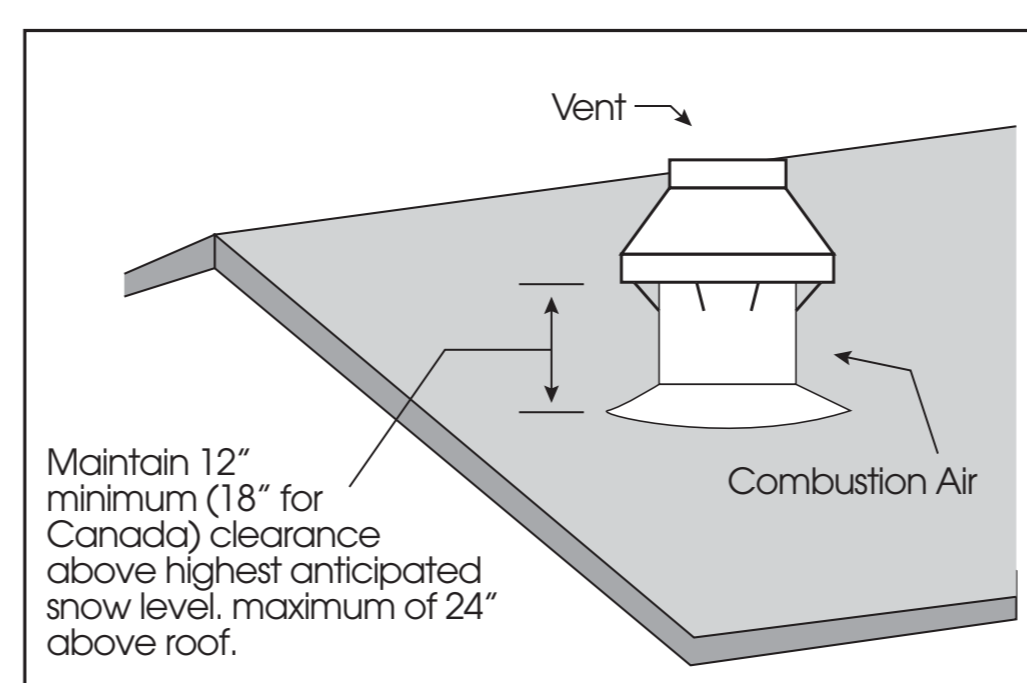

Figure 2-Typical Roof Installation

MODEL	INTAKE/VENT NOM. PIPE SIZE	OVERALL ASSEMBLY LENGTH <sup>1</sup>	INTAKE PIPE OUTSIDE DIAMETER	AIR INLET PIPE LENGTH <sup>2</sup>
CVENT2	2"	34 3/4"	3 1/2"	21 1/4"

1. Shipping dimension. This may be field modified by cutting or extending both the intake and exhaust pipes. 12" is the minimum allowable length and 60" is the maximum allowable length for this dimension. SDR-26 PVC (D2241) only may be used for extending pipes. Do not extend pipes with Schedule 40 PVC or couplings.
2. This dimension will change if the intake/vent pipes are lengthened or shortened.

**NOTICE:** Some local code inspectors are not familiar with concentric vents. Be sure to check local code requirements and acceptability prior to installation.

### VERTICAL ROOF MOUNTING

NOTE: Roof mounting is recommended as it allows less intake air contaminants and reduces ground-level exhaust.

1. Use furnace installation instructions to determine pipe diameter.
2. Determine correct Concentric Vent size for the pipe diameter selected.
3. Determine the best location for the Concentric Vent.
4. Cut a 4" diameter hole for CVENT-2, 2" kit.
5. Partially assemble Concentric Vent kit. Follow furnace installation instructions for cleaning and cementing.
  - a. Cement "Y" fitting to larger diameter air inlet pipe (Figure 1).
  - b. Cement combustion air inlet cap to smaller diameter pipe (Figure 1).
6. Install "Y" fitting and pipe assembly through hole and roof boot/flashing (user supplied).
7. Secure to roof (Figure 3) using metal strapping or equivalent support material (user supplied).
8. Install combustion air inlet cap and small diameter pipe assembly into roof. Cement and bottom small diameter pipe in "Y" concentric fitting.
9. Cement furnace combustion air and vent pipes to Concentric Vent. Refer to Figure 3 for proper pipe attachment.
10. Check installation by allowing furnace to run through one cycle.

NOTE: Keep assembly free of insulation during installation.

NOTE: Multiple Concentric Vent kits may be installed vertically following the same clearances between vent outlets as shown in Figure 6.

NOTE: Termination height must be above roof surface or anticipated snow level (minimum 12" in U.S. or minimum 18" in Canada) as shown in Figures 2 & 3.

NOTE: If assembly is too short, the 2 pipes supplied in the kit may be replaced by using same diameter, field supplied SDR-26 PVC (D2241) pipe. Do not extend pipes with Schedule 40 PVC or couplings. The additional wall thickness will restrict combustion air and may cause operational problems. Do not extend air inlet pipe more than 60" (Figure 3).

**CAUTION:** Do not use field supplied couplings to extend pipes.

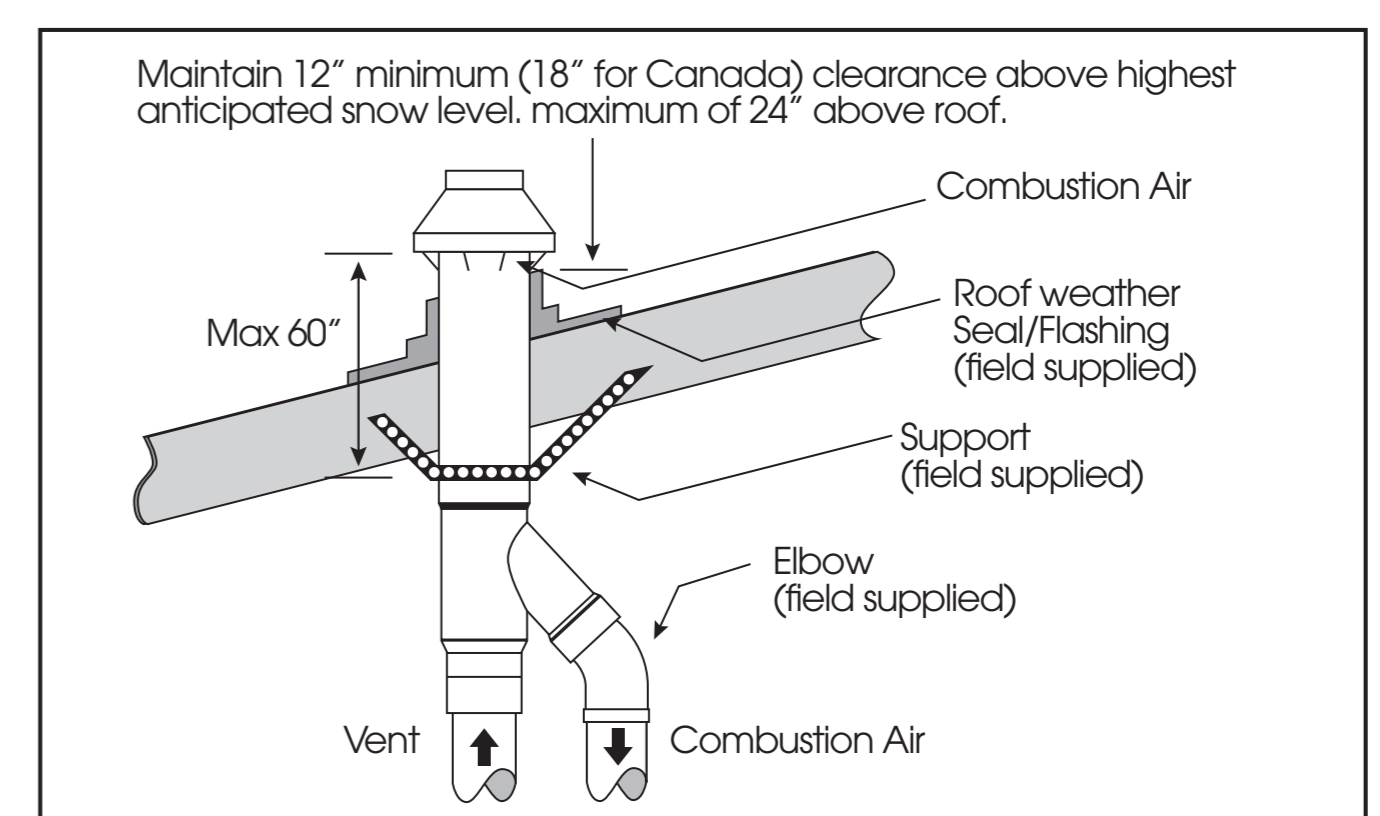

Figure 3-Typical Roof Install



0 195247 110740 17