

Contents

How to Select the Butterfly Retrofit Solution pg 127
 Butterfly Valve Retrofit Actuators..... pg 128

Solutions for Specific Manufacturer and Part Number

Apollo..... pg 130
 Belimo..... pg 131
 Bray pg 133
 Centerline pg 135
 Challenger pg 138
 Chemtrol..... pg 139
 Dezurik pg 140
 Flowseal pg 141
 FNW pg 142
 Gruvlok..... pg 143
 Hammond..... pg 145
 Jamesbury..... pg 146
 Jenkins pg 147
 Johnson Controls pg 148
 Keystone..... pg 149
 Keystone K-LOK..... pg 149
 Metraflex..... pg 152
 Milwaukee..... pg 153
 Mueller..... pg 155
 Nibco pg 156
 PDC..... pg 157
 Quartermaster pg 158
 Victaulic pg 159
 Watts pg 161

Custom Butterfly Valve Retrofit Solutions, Instructions pg 162
 Custom Butterfly Valve Retrofit Solution Form pg 163
 Component Identification..... pg 164
 UFLK/UFSP Retrofit Solution (2-Way Valves)..... pg 167
 SY...Series Butterfly Retrofit Solution (2-Way Valves)..... pg 169
 UFLK/UFSP Retrofit Solution (3-Way Valves)..... pg 174
 SY...Series Butterfly Retrofit Solution (3-Way Valves)..... pg 177
 Valve Accessories pg 185
 Custom Ball Valve Retrofit Solution, Instructions pg 186
 Custom Ball Valve Retrofit Solution Form pg 187
 Custom Ball Valve Retrofit Solution, Dimensions..... pg 189
 Actuator/Valve Specification pg 199
 Terms and Conditions pg 203
 Platinum Distributors pg 205



Butterfly Valve:
UFLK Series **Linkage Solution**
 2-way Valves
 3-way Valves

Retrofit Solutions for Virtually any Valve

Manufacturers:

Butterfly: Bray, Centerline, Keystone, Flowseal and more

Control: On/Off, Floating, 2-10VDC
 Multi-Function Technology®
 Spring Return or
 Non-Spring Return

M40045 - 10/10 - SUBJECT TO CHANGE. © BELIMO AIRCONTROLS (USA), INC.



Butterfly Valve Retrofit

Tips for choosing a butterfly valve retrofit solution



Dimensions with 2-Way Valve

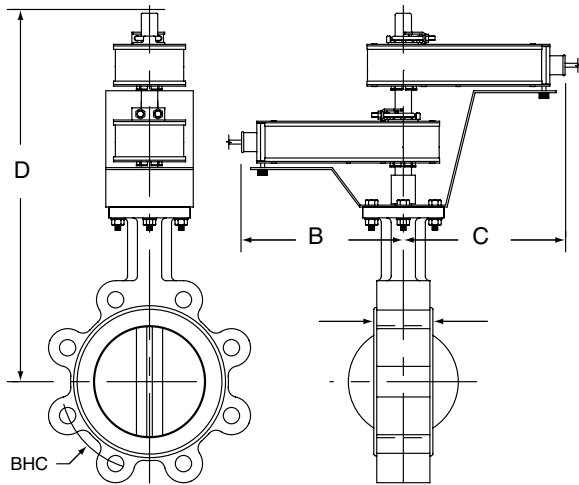

BF2WUDIM

Dimensions with 2-Way Valve

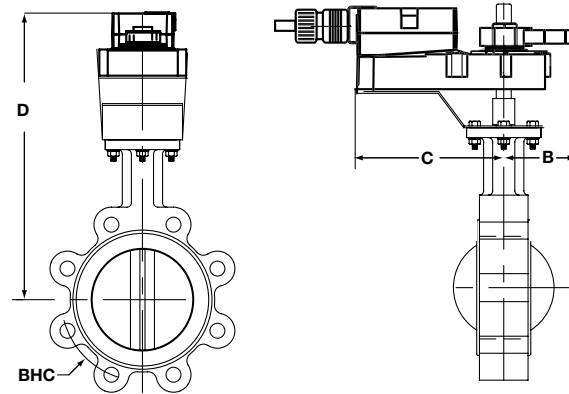

AM_GM_LineRevised

Maximum Dimensions (Inches)

Size	B	C	D(Max)	Actuator
2"	9	9	19.5	AF
2"	7	7	15	AMB(X)
2"	4.25	4.25	15.5	SY1...
2"	8	13	20.25	SY2...
2½"	9	9	20	AF
2½"	9	9	20	2*AF
2½"	7	7	15.5	AMB(X)
2½"	4.25	4.25	16	SY1...
2½"	8	13	20.75	SY2...
3"	7	7	16	AMB(X)
3"	8	8	16	GMB(X)
3"	9	9	20.5	2*AF
3"	4.25	4.25	16.25	SY1...
3"	8	13	21	SY2...
4"	8	8	17	GMB(X)
4"	9	9	21	2*AF
4"	8	8	21	2*GMB(X)
4"	8	13	21.75	SY2...
5"	8	8	17.5	GMB(X)
5"	9	9	22	2*AF
5"	8	13	22.25	SY2...
6"	8	8	22.5	GMB(X)
6"	8	13	23	SY2...
6"	8	13	22.75	SY3...
8"	8	13	24.25	SY3...
8"	12	15	29	SY4...
10"	8	13	25.5	SY3...
10"	12	15	30	SY4...
12"	8	13	27.25	SY3...
12"	12	15	32	SY4...
14"	12	15	33	SY5...
16"	12	15	34.5	SY6...
18"	14	21	39.25	SY8...
20"	14	21	41.5	SY8...
24"	14	22	53.25	SY11...
30"	14	22	57.5	SY12...

Application Notes

1. Dimensions are approximate
2. Custom kits may be taller and varies by application needs
3. Dimension "D" allows for actuator removal without the need to remove the valve from the pipe.
4. Dual actuated valves have single actuators mounted on each valve shaft.

M40045 - 10/10 - SUBJECT TO CHANGE. © BELIMO AIRCONTROLS (USA), INC.

How to select a Butterfly Valve Retrofit Solution

Follow the four steps listed below when ordering a butterfly valve retrofit kit.

Example: Centerline C200 Series, 2½" valve, using a **Non-Spring Return** Belimo actuator.

- 1** Identify the **Valve Manufacturer, Valve Series** and **Valve Size**.
- 2** Determine the type of actuator you require: Belimo Spring Return, Non-Spring or SY Series Industrial. Belimo Spring and Non-Spring actuators are typically only available on smaller sizes.
Look at the solution using the Non-Spring Return Belimo Actuator. Looking at the **UFLK3500**, the **GM** Series actuator will provide a **200 psi close-off** for the **2½" valve** with **Non-Spring Return** actuation.
- 3** Use the actuator listings to make your final actuator selection. Decide between **GMX24-3-X1** and **GMX24-MFT-X1**.
ACTUATOR NOT INCLUDED IN THE LIST PRICE OF THE LINKAGE.
- 4** HOW TO ORDER: **Item 1 1pc UFLK3500**
Item 2 1pc GMX24-MFT-X1



1 Select linkage solution based on the **Valve Number, Configuration, and Size**; select the proper **Linkage Solution** for your valve.

EXAMPLE PAGE

Centerline

C200 Round Top Series Butterfly Valves
Linkage/Actuator Selection Guide

Valve Body Model	Valve Configuration	Size	Failsafe	Close-Off psi	Belimo Actuator Series (Sold Separately)	Belimo Linkage	
C200 Round Top Series Butterfly Valves	2-way	2"	No	200	AM	UFLK3500	
			Yes	200	AF	UFLK3500	
		2½"	No	200	GM	UFLK3500	
			Yes	200	2*AF	UFLK3502	
		3"	No	200	GM	UFLK3500	
			Yes	200	2*AF	UFLK3502	
	2-way	2-way	2"	No	200	SY1	UFLK3538
				Yes	200	SY2	UFLK3540
			2½"	No	200	GM	UFLK3500
				Yes	200	2*AF	UFLK3502
			3"	No	200	GM	UFLK3500
				Yes	200	2*AF	UFLK3502

UFLK1300

Example: **Centerline C200 Series, 2½" valve** using a **non-spring return** Belimo actuation.

Choose correct linkage **UFLK3500**.

- 2** Verify close-off is suitable for application.
Looking at the **UFLK3500**, the **GM** Series actuator will provide **200 psi close-off** for the **2½" valve**.

MODEL	Non-Spring Return Actuators					
	Control Input	Feedback	Power Supply	Running Time(s) [Default]	VA Rating	Aux. Switch
BASIC PRODUCTS						
GMB24-3-X1	On/Off, Floating Point	Add-on	24 VAC/DC	150 seconds	6	Add-on
GMB24-SR	2-10 VDC (4-20mA*)	2-10 VDC	24 VAC/DC	150 seconds	6.5	Add-on
CUSTOMIZE IT						
GMX24-3	On/Off, Floating Point	Add on	24 VAC/DC	150 seconds	7	Add-on
GMX24-SR	2-10 VDC (4-20mA*)	2-10 VDC	24 VAC/DC	150 seconds	6.5	Add-on
GMX24-PC	0-20 V Phasecut	2-10 VDC	24 VAC/DC	150 seconds	7	Add-on
GMX24-MFT-X1	Various	Various	24 VAC/DC	Various	7	Add-on
GMX24-MFT95-X1	0 to 135 Ω	2-10 VDC	24 VAC/DC	150 seconds	7	Add-on
GMX120-3	On/Off, Floating Point	Add on	100-240 VAC	150 seconds	9	Add-on

‡ For applications that require more torque the GMB Series can be dual mounted. A maximum of 2 GMB/X... Series actuators can be mechanically connected to one damper or valve shaft. The torque is 640 in-lb.
*With the 500 Ω resistor added.

- 3** Select actuator based on needed control type.
Decide between **GMB24-3-X1** and **GMX24-MFT-X1**.

Complete Ordering Example:

- 4** Item 1: **UFLK3500**
Item 2: **GMX24-MFT-X1**

SY Series Actuators

SERIES	MODEL	TORQUE	RUN TIME(S) 90°@60Hz	POWER SUPPLY	DUTY CYCLE	CONTROL			FEEDBACK
						PROPORTIONAL	3 POINT	ON/OFF	
SY1	SY1-110	35 Nm / 310 in-lb	12 seconds	120 VAC ±10%, 50/60 Hz	30%		•	•	none, opt 1k
	SY1-24	35 Nm / 310 in-lb	12 seconds	24 VAC ±10%, 50/60 Hz	30%		•	•	none, opt 1k
	SY1-220	35 Nm / 310 in-lb	12 seconds	230 VAC ±10%, 50/60 Hz	30%		•	•	none, opt 1k
	SY1-110P	35 Nm / 310 in-lb	12 seconds	120 VAC ±10%, 50/60 Hz	75%	•			2-10 VDC/4-20 mA
	SY1-24P	35 Nm / 310 in-lb	12 seconds	24 VAC ±10%, 50/60 Hz	75%	•			2-10 VDC/4-20 mA
SY1-220P	35 Nm / 310 in-lb	12 seconds	230 VAC ±10%, 50/60 Hz	75%	•			2-10 VDC/4-20 mA	
SY2	SY2-110	90 Nm / 801 in-lb	15 seconds	120 VAC ±10%, 50/60 Hz	30%		•	•	none, opt 1k
	SY2-24	90 Nm / 801 in-lb	15 seconds	24 VAC ±10%, 50/60 Hz	30%		•	•	none, opt 1k
	SY2-220	90 Nm / 801 in-lb	15 seconds	230 VAC ±10%, 50/60 Hz	30%		•	•	none, opt 1k
	SY2-120MFT	90 Nm / 801 in-lb	15 seconds	120 VAC ±10%, 50/60 Hz	75%	•			2-10 VDC/4-20 mA
	SY2-24MFT	90 Nm / 801 in-lb	15 seconds	24 VAC ±10%, 50/60 Hz	75%	•			2-10 VDC/4-20 mA
SY2-230MFT	90 Nm / 801 in-lb	15 seconds	230 VAC ±10%, 50/60 Hz	75%	•			2-10 VDC/4-20 mA	
SY3	SY3-110	150 Nm / 1335 in-lb	22 seconds	120 VAC ±10%, 50/60 Hz	30%		•	•	none, opt 1k
	SY3-24	150 Nm / 1335 in-lb	22 seconds	24 VAC ±10%, 50/60 Hz	30%		•	•	none, opt 1k
	SY3-220	150 Nm / 1335 in-lb	22 seconds	230 VAC ±10%, 50/60 Hz	30%		•	•	none, opt 1k
	SY3-24MFT	150 Nm / 1335 in-lb	22 seconds	120 VAC ±10%, 50/60 Hz	75%	•			2-10 VDC/4-20 mA
	SY3-120MFT	150 Nm / 1335 in-lb	22 seconds	120 VAC ±10%, 50/60 Hz	75%	•			2-10 VDC/4-20 mA
SY3-230MFT	150 Nm / 1335 in-lb	22 seconds	230 VAC ±10%, 50/60 Hz	75%	•			2-10 VDC/4-20 mA	
SY4	SY4-110	400 Nm / 3560 in-lb	16 seconds	120 VAC ±10%, 50/60 Hz	30%		•	•	none, opt 1k
	SY4-24	400 Nm / 3560 in-lb	16 seconds	24 VAC ±10%, 50/60 Hz	30%		•	•	none, opt 1k
	SY4-220	400 Nm / 3560 in-lb	16 seconds	230 VAC ±10%, 50/60 Hz	30%		•	•	none, opt 1k
	SY4-24MFT	400 Nm / 3560 in-lb	16 seconds	120 VAC ±10%, 50/60 Hz	75%	•			2-10 VDC/4-20 mA
	SY4-120MFT	400 Nm / 3560 in-lb	16 seconds	120 VAC ±10%, 50/60 Hz	75%	•			2-10 VDC/4-20 mA
SY4-230MFT	400 Nm / 3560 in-lb	16 seconds	230 VAC ±10%, 50/60 Hz	75%	•			2-10 VDC/4-20 mA	
SY5	SY5-110	500 Nm / 4450 in-lb	22 seconds	120 VAC ±10%, 50/60 Hz	30%		•	•	none, opt 1k
	SY5-24	500 Nm / 4450 in-lb	22 seconds	24 VAC ±10%, 50/60 Hz	30%		•	•	none, opt 1k
	SY5-220	500 Nm / 4450 in-lb	22 seconds	230 VAC ±10%, 50/60 Hz	30%		•	•	none, opt 1k
	SY5-24MFT	500 Nm / 4450 in-lb	22 seconds	120 VAC ±10%, 50/60 Hz	75%	•			2-10 VDC/4-20 mA
	SY5-120MFT	500 Nm / 4450 in-lb	22 seconds	120 VAC ±10%, 50/60 Hz	75%	•			2-10 VDC/4-20 mA
SY5-230MFT	500 Nm / 4450 in-lb	22 seconds	230 VAC ±10%, 50/60 Hz	75%	•			2-10 VDC/4-20 mA	
SY6	SY6-110	650 Nm / 5785 in-lb	28 seconds	120 VAC ±10%, 50/60 Hz	30%		•	•	none, opt 1k
	SY6-220	650 Nm / 5785 in-lb	28 seconds	230 VAC ±10%, 50/60 Hz	30%		•	•	none, opt 1k
	SY6-120MFT	650 Nm / 5785 in-lb	28 seconds	120 VAC ±10%, 50/60 Hz	75%	•			2-10 VDC/4-20 mA
	SY6-230MFT	650 Nm / 5785 in-lb	28 seconds	230 VAC ±10%, 50/60 Hz	75%	•			2-10 VDC/4-20 mA
SY7	SY7-110	1000 Nm / 8900 in-lb	46 seconds	120 VAC ±10%, 50/60 Hz	30%		•	•	none, opt 1k
	SY7-220	1000 Nm / 8900 in-lb	46 seconds	230 VAC ±10%, 50/60 Hz	30%		•	•	none, opt 1k
	SY7-120MFT	1000 Nm / 8900 in-lb	46 seconds	120 VAC ±10%, 50/60 Hz	75%	•			2-10 VDC/4-20 mA
	SY7-230MFT	1000 Nm / 8900 in-lb	46 seconds	230 VAC ±10%, 50/60 Hz	75%	•			2-10 VDC/4-20 mA
SY8	SY8-110	1500 Nm / 13350 in-lb	46 seconds	120 VAC ±10%, 50/60 Hz	30%		•	•	none, opt 1k
	SY8-220	1500 Nm / 13350 in-lb	46 seconds	230 VAC ±10%, 50/60 Hz	30%		•	•	none, opt 1k
	SY8-120MFT	1500 Nm / 13350 in-lb	46 seconds	120 VAC ±10%, 50/60 Hz	75%	•			2-10 VDC/4-20 mA
	SY8-230MFT	1500 Nm / 13350 in-lb	46 seconds	230 VAC ±10%, 50/60 Hz	75%	•			2-10 VDC/4-20 mA

Proportional actuators will accept 0-10 VDC, 2-10 VDC, or 4-20 mA control signals as standard.

All SY actuators are non-spring return, but can be used with NSV-SY back up systems for fail-safe applications.

These products carry a two year warranty when sold as part of an assembly or with a UFLK retrofit kit.

M40045 - 10/10 - SUBJECT TO CHANGE. © BELIMO AIRCONTROLS (USA), INC.

Butterfly Valve Retrofit Actuators

Actuator Selection Guide



SY Series Actuators

SERIES	MODEL	TORQUE	RUN TIME(S) 90°@60Hz	POWER SUPPLY	DUTY CYCLE	CONTROL			FEEDBACK
						PROPORTIONAL	3 POINT	ON/OFF	
SY9	SY9-110	2000 Nm / 17800 in-lb	58 seconds	120 VAC ±10%, 50/60 Hz	30%		•	•	none, opt 1k
	SY9-220	2000 Nm / 17800 in-lb	58 seconds	230 VAC ±10%, 50/60 Hz	30%		•	•	none, opt 1k
	SY9-120MFT	2000 Nm / 17800 in-lb	58 seconds	120 VAC ±10%, 50/60 Hz	75%	•			2-10 VDC/4-20 mA
	SY9-230MFT	2000 Nm / 17800 in-lb	58 seconds	230 VAC ±10%, 50/60 Hz	75%	•			2-10 VDC/4-20 mA
SY10	SY10-110	2500 Nm / 22250 in-lb	58 seconds	120 VAC ±10%, 50/60 Hz	30%		•	•	none, opt 1k
	SY10-220	2500 Nm / 22250 in-lb	58 seconds	230 VAC ±10%, 50/60 Hz	30%		•	•	none, opt 1k
	SY10-120MFT	2500 Nm / 22250 in-lb	58 seconds	120 VAC ±10%, 50/60 Hz	75%	•			2-10 VDC/4-20 mA
	SY10-230MFT	2500 Nm / 22250 in-lb	58 seconds	230 VAC ±10%, 50/60 Hz	75%	•			2-10 VDC/4-20 mA
SY11	SY11-110	3000 Nm / 26700 in-lb	58 seconds	120 VAC ±10%, 50/60 Hz	30%		•	•	none, opt 1k
	SY11-220	3000 Nm / 26700 in-lb	58 seconds	230 VAC ±10%, 50/60 Hz	30%		•	•	none, opt 1k
	SY11-120MFT	3000 Nm / 26700 in-lb	58 seconds	120 VAC ±10%, 50/60 Hz	75%	•			2-10 VDC/4-20 mA
	SY11-230MFT	3000 Nm / 26700 in-lb	58 seconds	230 VAC ±10%, 50/60 Hz	75%	•			2-10 VDC/4-20 mA
SY12	SY12-110	3500 Nm / 31150 in-lb	58 seconds	120 VAC ±10%, 50/60 Hz	30%		•	•	none, opt 1k
	SY12-220	3500 Nm / 31150 in-lb	58 seconds	230 VAC ±10%, 50/60 Hz	30%		•	•	none, opt 1k
	SY12-120MFT	3500 Nm / 31150 in-lb	58 seconds	120 VAC ±10%, 50/60 Hz	75%	•			2-10 VDC/4-20 mA
	SY12-230MFT	3500 Nm / 31150 in-lb	58 seconds	230 VAC ±10%, 50/60 Hz	75%	•			2-10 VDC/4-20 mA

Proportional actuators will accept 0-10 VDC, 2-10 VDC, or 4-20 mA control signals as standard.

All SY actuators are non-spring return, but can be used with NSV-SY back up systems for fail-safe applications.

These products carry a two year warranty when sold as part of an assembly or with a UFLK retrofit kit.

ROTARY ACTUATORS

SERIES	MODEL	Spring Return	Electronic Fail Safe	Control Input	Feedback Position	Power Supply
AF Series*	AF24 US, AFB24	•		24 VAC/DC		24 VAC/DC
	AFX24-MFT-X1	•		Variable with MFT (VDC, PWM, Floating Pt., On/Off)	variable VDC	24 VAC/DC
AM Series*	AMB24-3-X1			24 VAC/DC		24 VAC/DC
	AMX24-MFT-X1			Variable with MFT (VDC, PWM, Floating Pt., On/Off)	variable VDC	24 VAC/DC
GM Series*	GMB24-3-X1			24 VAC/DC		24 VAC/DC
	GMX24-MFT-X1			Variable with MFT (VDC, PWM, Floating Pt., On/Off)	variable VDC	24 VAC/DC
GK Series*	GKB24-3-X1		•	24 VAC/DC		24 VAC/DC
	GKX24-MFT-X1		•	Variable with MFT (VDC, PWM, Floating Pt., On/Off)	variable VDC	24 VAC/DC

*Please consult the Damper sections for a full list of product offerings. Standard run times should be considered in the selection. All air side products are applicable for retrofit kits.

Select "X1" actuators come with a handle.

MULTI-FUNCTION TECHNOLOGY

ROTARY ACTUATOR CODES	P-CODE		Control Input	Running Time	Built-in Feedback
	P-10001	A01	2-10 VDC	150 seconds	2-10 VDC
	P-10002	A02	0-10 VDC	150 seconds	0-10 VDC
	P-10028	A28	0-10 VDC	150 seconds	0-10 VDC
	P-10063	A63	0.5-4.5 VDC	150 seconds	0.5-4.5 VDC
	P-10064	A64	5.5-10 VDC	150 seconds	5.5-10 VDC
	P-20002	W02	0.02-5.00 seconds PWM	150 seconds	2-10 VDC
	P-20003	W03	0.10-25.5 seconds PWM	150 seconds	2-10 VDC
	P-30001	F01	Floating Pt.	150 seconds	2-10 VDC
	P-40002	J02	On/Off	150 seconds	2-10 VDC

SY MULTI-FUNCTION TECHNOLOGY

Description	MFT-CODE	Control Input	Built-in Feedback	Loss of Signal	Running Time
MFT	ACE	2...10V	2...10V	stop	actuator(s) constant
MFT	ACF	0.5...10V	0.5...10V	stop	actuator(s) constant
MFT	ACG	4...20mA	4...20mA	stop	actuator(s) constant
MFT	ACH	4...20mA	2...10V	stop	actuator(s) constant
MFT	ACJ	2...10V	2...10V	open	actuator(s) constant
MFT	ACK	0.5...10V	0.5...10V	open	actuator(s) constant
MFT	ACL	4...20mA	4...20mA	open	actuator(s) constant
MFT	ACM	4...20mA	2...10V	open	actuator(s) constant
MFT	ACN	2...10V	2...10V	close	actuator(s) constant
MFT	ACP	0.5...10V	0.5...10V	close	actuator(s) constant
MFT	ACR	4...20mA	4...20mA	close	actuator(s) constant
MFT	ACS	4...20mA	2...10V	close	actuator(s) constant

All other configurations carry a \$34.00 list price.

Standard delivery may vary, please consult your customer service representative for the latest lead time(s).

800-543-9038 USA

866-805-7089 CANADA

203-791-8396 LATIN AMERICA



Valve Body Model	Valve Configuration	Size	Failsafe	Close-Off psi	Belimo Actuator Series (Sold Separately)	Belimo Linkage		
CH100 Series Butterfly Valves	2-way	2"	No	200	AM	UFLK3600		
						SY1	UFLK3622	
						SY2	UFLK3624	
			Yes	200	2*AF	UFLK3602		
		2½"	No	200	GM	UFLK3600		
						SY1	UFLK3622	
						SY2	UFLK3624	
			Yes	200	2*AF	UFLK3602		
		3"	No	200	GM	UFLK3600		
						SY1	UFLK3622	
						SY2	UFLK3624	
			Yes	200	2*AF	UFLK3602		
		4"	No	200	GK	UFLK3600		
						GM	UFLK3600	
						SY1	UFLK3622	
			Yes	200	2*GK	UFLK3608		
		5"	No	200	SY2	UFLK3626		
		6"	No	200	SY3	UFLK3628		
	8"	No	200	SY4	UFLK3630			
	10"	No	200	SY4	UFLK3632			
	12"	No	200	SY5	UFLK3634			
	3-way	2"	No		200	GM	UFLK6600	
							SY1	UFLK6624
							SY2	UFLK6626
			Yes	200	2*AF	UFLK6602		
		2½"	No	200	GK	UFLK6600		
						GM	UFLK6600	
						SY2	UFLK6626	
			Yes	200	2*AF	UFLK6602		
		3"	No	200	GK	UFLK6600		
					2*GM	UFLK6602		
					SY2	UFLK6626		
		Yes	200	2*GK	UFLK6602			
4"		No	200	SY2	UFLK6628			
5"		No	200	SY3	UFLK6628			
6"		No	200	SY4	UFLK6630			
8"		No	200	SY4	UFLK6632			
10"		No	200	SY5	UFLK6634			
12"		No	200	SY7	UFLK6636			

All close-off pressures listed are approximate and based on valve condition and application.

M40045 - 10/10 - Subject to change. © Belimo Aircontrols (USA), Inc.

**Industrial Electric 2-way
Generic – Must complete BFV Retrofit Form**

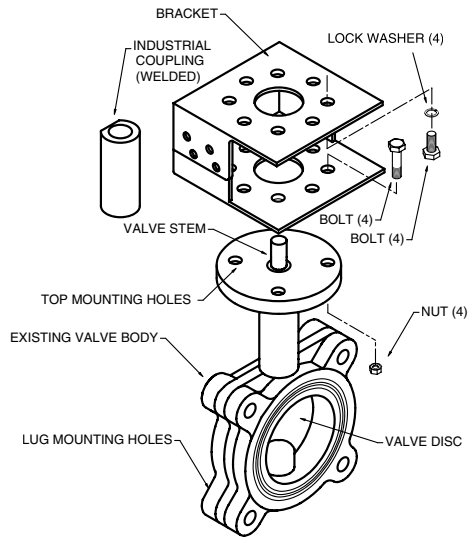

**UFSP0020
UFSP0022**

**SY1 - SY8
SY9 - SY12**

**Industrial Electric 3-way
Generic – Must complete BFV Retrofit Form**

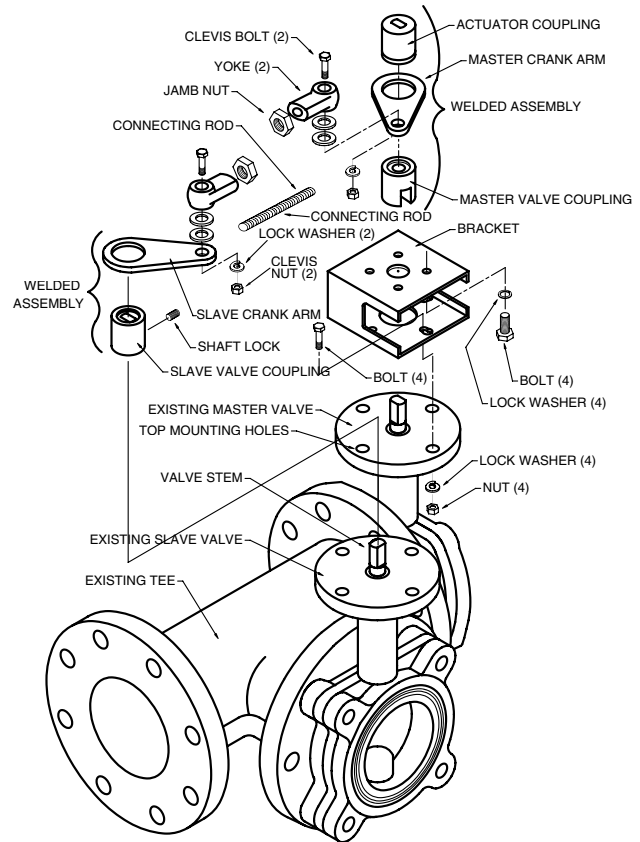

**UFSP0024
UFSP0026**

**SY1 - SY8
SY9 - SY12**

NOTE: 3-way bracket configuration shown is only one of many possible arrangements.

M40045 - 10/10 - SUBJECT TO CHANGE. © BELIMO AIRCONTROLS (USA), INC.

Assembly Procedure for SY...Retrofit Solution

Retrofit Requirement:

The initial step is to determine if your application can accept a retrofit solution. As shown below (Fig. 1), the valve stem must not be located below the horizontal plane. If this condition exists, the SY actuator could not be used in this situation. A Belimo technical support person is available to help determine what solution best fits your application. A typical solution is shown in Fig. 2.

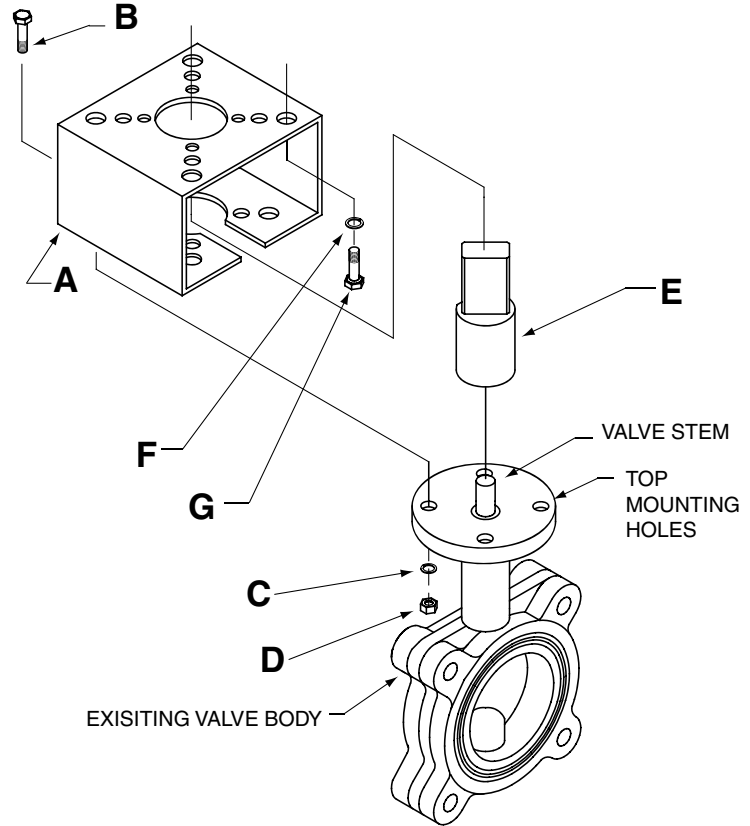
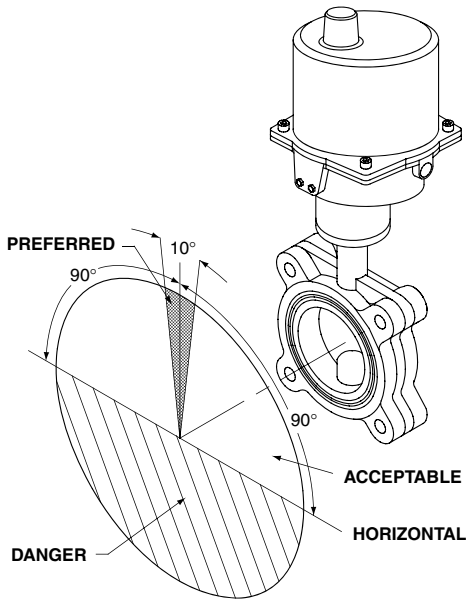

Assembly Procedure (Mechanical)



Step 1) The valve must be stripped down to its basic form. Remove all other linkage components before starting the assembly sequence below. The linkage components have been designed to attach to the existing valve flange rather than to any existing hardware.



Step 2) The valve has either flats, a key slot, holes or a mark indicating the position of the disc with respect to the shaft. Usually, the flats, keys, holes and marks are PARALLEL to the valve disc. The photo at left shows the flattened shaft in the CLOSED position.

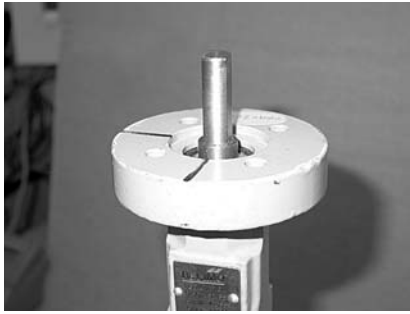

Step 3) The valve MUST be in the OPEN position before starting the retrofit process. The photo at the left shows the shaft flats are PARALLEL to the piping, but the disc is PARALLEL to the flats, thereby indicating the valve disc is in the fully OPEN position. You MUST verify the disc is fully OPEN before proceeding.

Step 3) The valve MUST be in the OPEN position before starting the retrofit process. The photo at the left shows the shaft flats are PARALLEL to the piping, but the disc is PARALLEL to the flats, thereby indicating the valve disc is in the fully OPEN position. You MUST verify the disc is fully OPEN before proceeding.



Step 7) The SY actuator is shipped in the OPEN position. Make sure the actuator is in the OPEN position before attaching to the valve/coupling assembly. The SY actuator turns counter clockwise (CCW) to the OPEN position, when viewed from ABOVE the actuator.

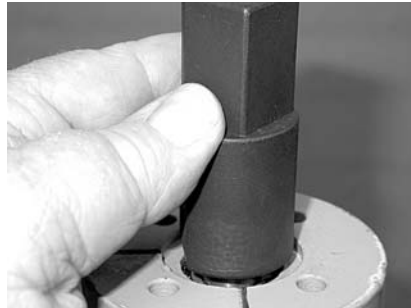

can easily reference the position of the valve after the actuator is attached.

Step 4) Place the coupling (E) over the valve stem. It can be assembled in two different positions 180 degrees apart, but either position is OK. It would be helpful at this time to make a mark on the coupling and on the valve body so you

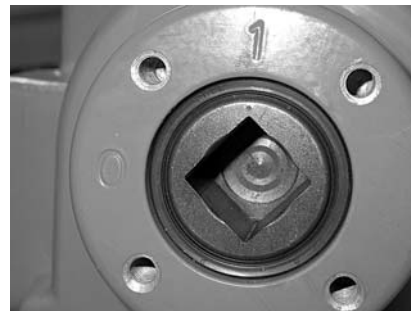

Step 8) Verify that the SY actuator is in the OPEN position also by looking at the bottom of the actuator. There is a dimple mark punched in the output shaft which will align with the "1" mark when the actuator is in the OPEN position.

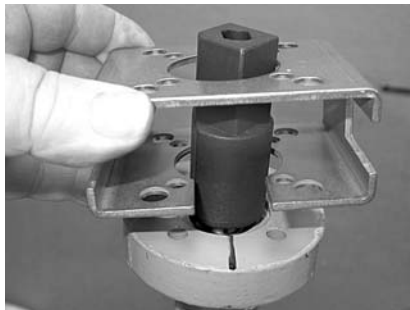

Step 5) Install the actuator mounting bracket (A) onto the valve top works flange as shown.



actuator with the square drive or keys in the coupling (C). The SY actuator will slide completely over the drive square and will rest ON the mounting bracket (A).

Step 9) Stand with the valve face (where the piping flange connects to the valve body) towards you. Hold the SY actuator with the handwheel on the RIGHT, and the EMT connectors to your LEFT. Align the square drive or keyway in the SY



Step 6) Insert the four mounting bolts (B), lockwashers (C), and the hex nuts (D). Do NOT tighten at this time.



Step 10) Attach the hand knob to the hand wheel as shown below (if not already completed).



Step 11) Tighten the jam nut to prevent the hand knob from becoming loose.



Step 12) Insert the four hex bolts (G) and lock washers (F) through the bracket and into the bottom of the SY actuator as shown. Do NOT tighten until all four sets have been installed. Slight twisting of the entire SY actuator will facilitate alignment of the bolts.



Step 13) After all four have been inserted, tighten accordingly.



Step 14) Now tighten the four bracket bolts (B, C, D) assembled previously in step 6 .



Step 15) When mechanical assembly is complete, the SY actuator and valve body should be oriented as shown below. The actuator is in the OPEN position, and the valve disc is fully OPEN. All bolts are tight, and electrical checkout is now possible.

Application Note:

The hand wheel on the SY actuator is engaged at all times but does not rotate when the actuator is running. It is possible at anytime to turn the hand wheel by simply rotating it CW or CCW. The hand wheel does NOT need to be pulled or pushed into the actuator to make it operational. However, it should be noted that if a control signal and power is present at the actuator when the hand wheel is turned, the actuator will return to its controlled position. If it is desired to have the actuator maintain its position after turning the hand wheel, it will be necessary to remove power from the actuator, either at the source or by use of an optional SY-HOA local switch.

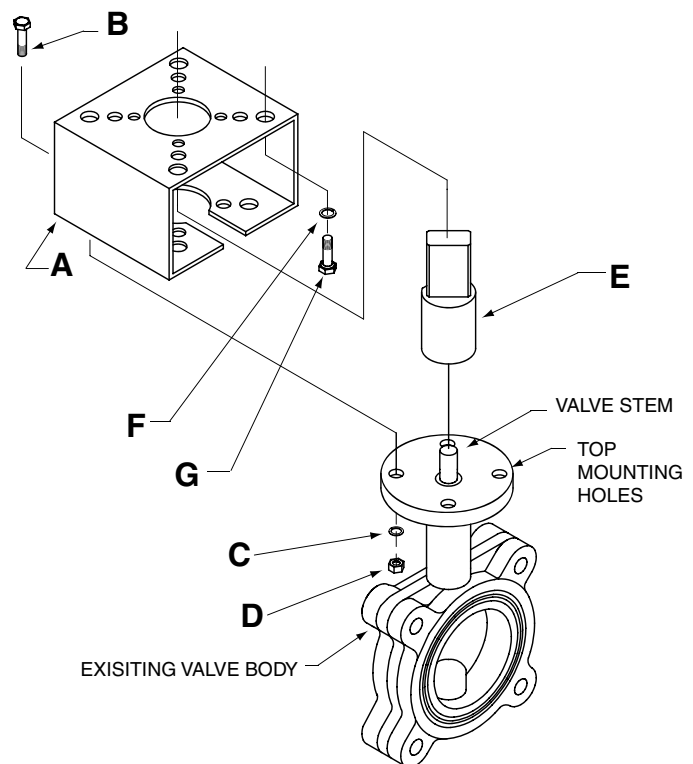

Assembly Procedure (Electrical), On/Off Models

WARNING

Hazard identification warnings appear at appropriate sections throughout this manual. Read these carefully.



Step 1) Remove the four hex bolts securing the cover to the base casting.



Step 6) Apply proper voltage to terminals 1 (Neutral) & 7 (Hot). Apply proper actuator voltage to terminals 1 (Neutral) & 4 (Hot) to drive the actuator CLOSED until the end-of-travel cam STOPS the actuator movement.

7. Visually check the position of the valve to make sure it reaches its full CLOSED position.



Step 2) Remove cover from the SY actuator. A flat blade screwdriver inserted carefully into the provided slot (as shown) will facilitate removal of the cover.

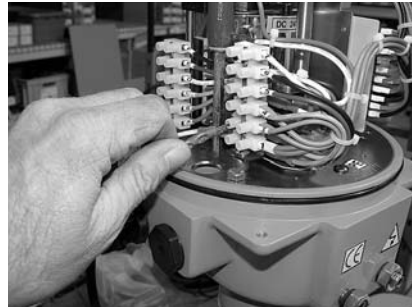

Step 8) Apply proper voltage to terminals 1 (Neutral) & 7 (Hot). Apply proper actuator voltage to terminals 1 (Neutral) & 3 (Hot) to drive the actuator OPEN until the end-of-travel cam STOPS the actuator movement.

Step 9) Visually check the position of the valve disc to make sure it reaches its full OPEN position.

Step 10) If the valve functions properly, mechanical assembly and electrical checkout are complete.

Step 3) Conduit entries into the SY actuator must be selected for their operating location (indoors protected, indoors wash down, outdoors, etc). Be sure to follow standard NEC guidelines when selecting conduit and connector types.

Step 4) Follow the wire sizing chart in the Installation Operation Manual (IOM) (Belimo p/n 71150-00001.C page 10) to make sure you use the correctly size wire when connecting the SY to your power source. Failure to follow the recommendations in the table could cause actuator failure or nuisance tripping.

Step 5) Follow the wiring diagrams in the IOM pages 18 (single) & 23 (multiple) for proper power and control wiring to the SY actuator. Make note of the following:

- a. Do NOT connect multiple actuators in parallel without isolation relays.
- b. Be sure "Hot" is connected to terminal #7 to enable the heater circuit, and "Neutral" is connected to terminal #1.

WARNING

FACTORY NOTE:

The SY actuators have been calibrated at the factory before shipping to you for use in this retrofit kit. The SY actuator calibration will suffice 99% of the time for your application. Improper calibration to the actuator may void your warranty. If you have any questions, please contact a Belimo technical support representative at 800-543-9038 for assistance.

M40045 - 10/10 - SUBJECT TO CHANGE. © BELIMO AIRCONTROLS (USA), INC.

SY... Series Butterfly Valve Retrofit Solution

Retrofitting 2-way Valves with Belimo SY Proportional Non-Spring Return Actuator



Assembly Procedure (Electrical), Proportional Models

Hazard Identification

Warnings appear at appropriate sections throughout this manual. Read these carefully.



Step 1) Remove the four hex bolts securing the cover to the base casting.

Step 6) Connect the proper electrical power and control wiring per the wiring diagrams located on pages 14-37.

Step 7) Check the operation of the actuator by commanding the control system to generate control signals matching the needs of the job to run the valve from fully CLOSED to fully OPEN, as well as a MID-POINT position. The indicator on the top of the SY actuator will be an indicator as to the position of the actuator, and therefore, the valve position.

Step 8) If the valve functions properly, mechanical assembly and electrical checkout are complete.



Step 2) Remove cover from the SY actuator. A flat blade screwdriver inserted carefully into the provided slot (as shown) will facilitate removal of the cover.

WARNING

FACTORY NOTE:

The SY actuators have been calibrated at the factory before shipping to you for use in this retrofit kit. The SY actuator calibration will suffice 99% of the time for your application. Improper calibration to the actuator may void your warranty. If you have any questions, please contact a Belimo technical support representative at 800-543-9038 for assistance.

Step 3) Conduit entries into the SY actuator must be selected for their operating location (indoors protected, indoors wash down, outdoors, etc). Be sure to follow standard NEC guidelines when selecting conduit and connector types.

Step 4) Follow the wire sizing chart in the Installation Operation manual (IOM) (Belimo p/n 70103-00001D page 17) to make sure you use the correct size wire when connecting the SY to your power source. Failure to follow the recommendations in the table could cause actuator failure or nuisance tripping.

Step 5) Follow the wiring diagrams in the IOM pages 14 through 37 for proper power and control wiring to the SY actuator.

Note: All SY1-P and SY2..12-MFT actuators are factory pre-set with the proper customer requested control programming.

M40045 - 10/10 - SUBJECT TO CHANGE. © BELIMO AIRCONTROLS (USA), INC.