

Comfort System

Hot water recirculation system

Installation and operating instructions



be
think
innovate

GRUNDFOS 

English (US) Installation and operating instructions

Original installation and operating instructions.

CONTENTS

	Page
1. Limited warranty	2
2. Symbols used in this document	3
3. Product introduction	3
3.1 Introduction	3
3.2 Delivery and handling	3
3.3 Applications	4
3.4 Identification	4
4. Installation	4
4.1 Pre-installation checklist	4
4.2 Electrical requirements	4
4.3 Three-step installation procedure	4
5. Maintenance and service	7
6. Technical data	8
6.1 Approvals	8
7. Fault finding	9
8. Disposal	9



Warning

Prior to installation, read these installation and operating instructions. Installation and operation must comply with national, state, and local regulations and accepted codes of good practice.

1. Limited warranty

Products manufactured by Grundfos Pumps Corporation (Grundfos) are warranted to the original user only to be free of defects in material and workmanship for a period of 24 months from date of installation, but not more than 30 months from date of manufacture. Grundfos' liability under this warranty shall be limited to repairing or replacing at Grundfos' option, without charge, FOB Grundfos' factory or authorized service station, any product of Grundfos' manufacture. Grundfos will not be liable for any costs of removal, installation, transportation, or any other charges which may arise in connection with a warranty claim. Products which are sold but not manufactured by Grundfos are subject to the warranty provided by the manufacturer of said products and not by Grundfos' warranty. Grundfos will not be liable for damage or wear to products caused by abnormal operating conditions, accident, abuse, misuse, unauthorized alteration or repair, or if the product was not installed in accordance with Grundfos' printed installation and operating instructions.

To obtain service under this warranty, the defective product must be returned to the distributor or dealer of Grundfos' products from which it was purchased together with proof of purchase and installation date, failure date, and supporting installation data. Unless otherwise provided, the distributor or dealer will contact Grundfos or an authorized service station for instructions.

Any defective product to be returned to Grundfos or a service station must be sent freight prepaid; documentation supporting the warranty claim and/or a Return Material Authorization must be included if so instructed.

GRUNDFOS WILL NOT BE LIABLE FOR ANY INCIDENTAL OR CONSEQUENTIAL DAMAGES, LOSSES, OR EXPENSES ARISING FROM INSTALLATION, USE, OR ANY OTHER CAUSES. THERE ARE NO EXPRESS OR IMPLIED WARRANTIES, INCLUDING MERCHANTABILITY OR FITNESS FOR A PARTICULAR PURPOSE, WHICH EXTEND BEYOND THOSE WARRANTIES DESCRIBED OR REFERRED TO ABOVE.

Some jurisdictions do not allow the exclusion or limitation of incidental or consequential damages and some jurisdictions do not allow limit actions on how long implied warranties may last. Therefore, the above limitations or exclusions may not apply to you. This warranty gives you specific legal rights and you may also have other rights which vary from jurisdiction to jurisdiction.

2. Symbols used in this document



Warning

If these safety instructions are not observed, it may result in personal injury.



Warning

If these instructions are not observed, it may lead to electric shock with consequent risk of serious personal injury or death.



Caution

If these safety instructions are not observed, it may result in malfunction or damage to the equipment.



Note

Notes or instructions that make the job easier and ensure safe operation.

3. Product introduction

3.1 Introduction

All Grundfos Comfort Systems are carefully inspected and tested before shipment in order to ensure long, efficient, trouble-free service. For maximum performance and reliability, please follow the instructions in this manual.



Warning

This is not an anti-scald device. After installation, you may find some warm water in the cold water line at the sink where the valve is installed. Once the cold water line is opened, the warm water will dissipate in a very short time.



Warning

For indoor use only.

A Grundfos Comfort System hot water recirculation system is designed to bring hot water in an instant to the hot water faucets in your home.

Since the system utilizes the existing cold water return line in the home, no separate new return line is required. No electricity is required under the sink.

The Grundfos Comfort System includes a circulator pump that installs on the water heater in your home, plus a valve that installs at the furthest faucet.

The direction of flow moves from the water heater through the recirculation pump, through the hot water supply line, and then back to the water heater through the existing cold water return line.



Fig. 1 Grundfos Comfort System

Pos.	Description
1	Pump body
2	Faceplate
3	Flex hoses
4	Undersink, Thermal Bypass Valve
5	Line cord
6	Timer
7	3/4" NPT discharge port

3.2 Delivery and handling

Examine the components carefully to make sure no damage has occurred to the pump during shipment. **Take care to ensure the pump is NOT dropped or mishandled; dropping will damage the pump.**

Kit includes:

- One Grundfos UP15 circulator with 24-hour timer and line cord
- one Undersink, Thermal Bypass Valve
- two valve mounting screws
- two 1/2" FNPS X 1/2" FNPS X 12", flex hoses
- one Installation and Operating Instructions.

3.3 Applications



Warning

The pump must not be used for the transfer of flammable liquids such as diesel oil, gasoline, and similar liquids.

Pump not for pool or marine use.



Warning

For indoor use only.

Grundfos Comfort System is intended for indoor residential potable drinking water use only; to be considered where there is no hot water return line available.

The pump is lubricated and cooled by the liquid being pumped. Therefore, the pumped liquid must always be allowed to circulate through the pump while it is in operation.

3.4 Identification

The pump's nameplate shows information about the pump's electrical requirements. Verify that the pump will be supplied with the proper voltage, phase, and frequency during operation. This pump's motor is designed to run on $\pm 10\%$ of the voltage shown on the nameplate.

4. Installation

4.1 Pre-installation checklist



Warning

Do not energize pump until properly installed.

Before beginning installation, review all installation procedures in this document to insure proper and safe installation. Failure to follow procedures described in this document could have impact upon warranty and may cause inadvertent property damage.

4.2 Electrical requirements

Warning

Risk of electric shock - this pump is supplied with a grounding conductor. To reduce the risk of electric shock, be certain that it is connected only to a properly grounded grounding type receptacle. The safe operation of this pump requires that it be grounded in accordance with national, state, and local governing codes and regulations.



The operating voltage and other electrical data are marked on the motor label. Make sure that the motor is suitable for the electrical supply on which it will be used.

4.3 Three-step installation procedure

4.3.1 Pump installation (step one)



Warning

Do not energize pump until properly installed.

Warning

When making piping connections, be sure to follow piping manufacturer's recommendations and all code requirements for piping material.

Caution

1. Close the supply water valve to the water heater (located, in most cases, above the hot water heater on the cold water inlet to the hot water heater).
2. Drain the water from the hot water pipe by opening a hot water faucet in the house. Let the water run until it stops flowing. Then drain remaining water from the hot water heater spigot.
Leave the faucet open until pump installation is complete. If water does not stop flowing, check to make sure the water to the hot water heater has been completely shut off.
3. Disconnect the hot water piping from the water heater hot water discharge; see fig. 2.
4. Install pump onto the water heater discharge, using the 3/4" female fitting and gasket supplied on the pump. Ensure that the pump shaft is horizontal. The pump should be installed so that the pump is pumping away from the hot water heater, towards the house. Confirm the direction of pumping by observing the flow arrow on the side of the pump housing. Be sure that the pump is not touching the exhaust vent piping (chimney) of a gas or oil fired hot water heater. See fig. 3.
5. Connect the hot water line to the 3/4" NPT discharge of the pump. Use pipe joint compound/pipe dope or Teflon[®] tape to seal threads when connecting to a 3/4" female NPT connection. If a gasketed flexible copper water heater connector is used, pipe joint compound/pipe dope or Teflon[®] tape is not required.
6. Reopen the supply valve to the hot water heater and allow the water to run until all the air has been purged from the piping.
7. Close faucet inside the house.
8. Plug the line cord of pump into a 115 V outlet. Be sure to route the power cord so that it does not touch the exhaust vent piping of a gas or oil fired hot water heater.
9. Using the timer, set the pump to operate around your peak use times (such as 30 minutes before the first shower until 15 minutes after the last shower. See section [4.3.3 Timer settings \(step three\)](#).

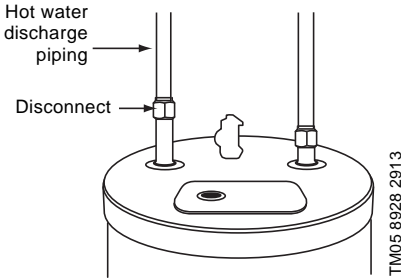

Fig. 2 Water heater hot water pipe disconnect

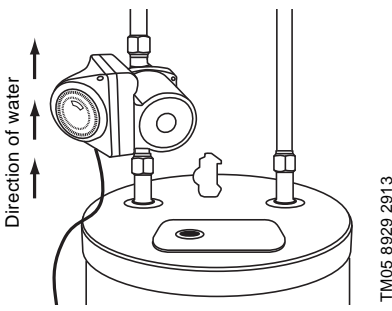

Fig. 3 Installation of pump onto water heater discharge

4.3.2 Thermal bypass valve installation (step two)

Warning
Caution Do not use Teflon® tape or pipe joint compound/pipe dope on the valve threads.

Warning
 Hand tighten flex hose connections, plus 1/4 turn with wrench.
Caution Overtightening of flex hose connections can result in valve damage, causing valve to leak and/or localized water damage.
 Only use the flex hoses provided in this kit. Use of other manufactured flex hoses could result in valve damage and/or void warranty.

Note
 When making piping connections, be sure to follow piping manufacturer's recommendations and all code requirements for piping material.

Note
 By plumbing convention, the hot water is on the left side and the cold water on the right side, when looking at the sink. Your piping may be different.

Valve location

For the greatest effect, the valve should be located at a faucet with the greatest piping distance from the hot water heater. If your home has a branched hot water line, more than one valve may be necessary.

Disconnecting the risers

1. Close both the hot and cold water angle stop valves below the sink; see fig. 4.
2. Disconnect the risers; see fig. 5.

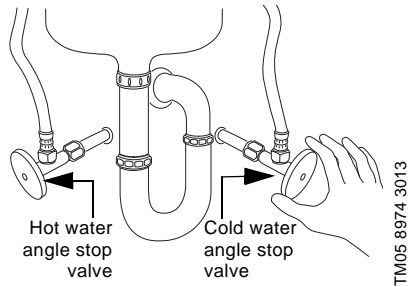

Fig. 4 Close hot and cold water angle stop valves under the sink before installing the bypass valve

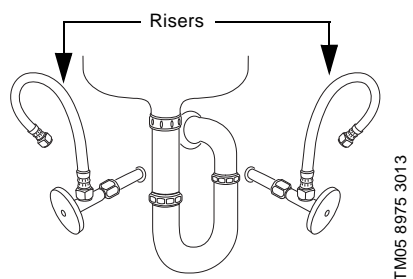
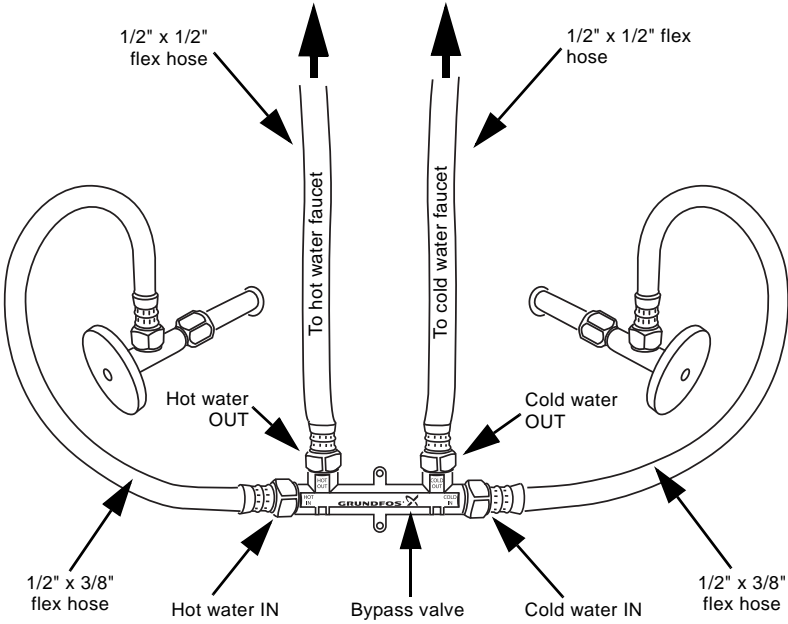

Fig. 5 Disconnect the risers before installing the bypass valve



TM05 8976 3013

Fig. 6 Connect bypass valve, flex hoses, and fittings as shown

Installing the bypass valve

1. Connect the 1/2" X 1/2" flex hoses to the ports on the bypass valve marked "HOT OUT" and "COLD OUT". See fig. 6.
2. Connect the 1/2" x 3/8" flex hoses to the ports on the bypass valve marked "HOT IN" and "COLD IN". See fig. 6.
3. Connect the 1/2" hose fitting from the "HOT OUT" port on the bypass valve to the left side of the faucet. See fig. 6.
4. Connect the 1/2" hose fitting from the "COLD OUT" port on the bypass valve to the right side of the faucet. See fig. 6.
5. Connect the 3/8" hose fitting from the "HOT IN" port on the bypass valve to the left angle stop valve. See fig. 6.
6. Connect the 3/8" hose fitting from the "COLD IN" port on the bypass valve to the right angle stop valve. See fig. 6.
7. Open both hot and cold water angle stop valves. Check for leaks.
8. Bypass valve may be mounted to the wall with supplied mounting screws if desired; two-hole mounting bracket flush with wall. See fig. 7.
9. For troubleshooting, see section 7. *Fault finding*.

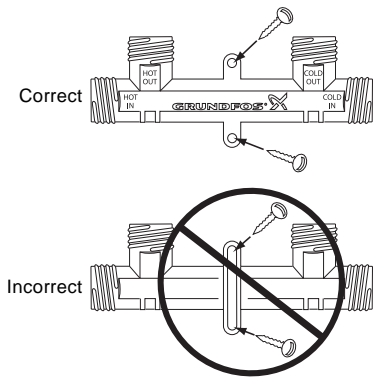

Fig. 7 Correct installation of bypass valve

TM05 8977 3013

4.3.3 Timer settings (step three)

The Grundfos timer control is designed only for use with specified Grundfos UP circulators installed in indoor hot water service systems.

The timer control is designed to turn the circulator on and off at preset times, allowing the user to select operation of the circulator during high use periods of the day.

Note Before the circulator is started, the system must be filled with liquid and vented.

To set the actual time of the day:

1. Turn the programming ring in the direction of the arrow, located on the timer face, until the timing arrow points to the desired time.
2. Insert the 115 V plug on the line cord from the pump into a properly grounded 115 V outlet. Be sure to route the power cord so that it does not touch the exhaust vent or piping from gas/oil fired hot water heater. The circulator will now start and is ready for timer settings selection.

Timer settings with three control options:

1. **Option one: 24 hours/day, 7 days/week (continuous pumping)**
Set the manual switch in the "ON" position. In this mode, the pump will not be controlled by the programming tab settings.
2. **Option two: Pumping controlled by specific times of the day**
Set the manual switch in the "TIMER" position. To set the specific "ON" and "OFF" times during the day, located on the programming ring, push the programming tabs either towards or away from the center of the ring.

Note that:

- Tabs pushed away from the center ring indicate the circulator is switched "ON".
 - Tabs pushed towards the center ring indicate the circulator is switched "OFF".
 - Each programming tab equals 15 minutes.
 - In case of power outage, the timer will not keep time. After power has been restored, reset the timer (see instructions in section [4.3.3 Timer settings \(step three\); To set the actual time of the day:](#)).
3. **Option three: No pumping**
Set the manual switch in the "OFF" position. In this mode the circulator will not be pumping. The timer will still keep the time of day.

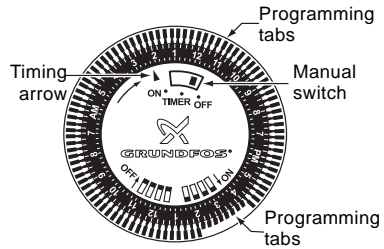

Fig. 8 Timer components

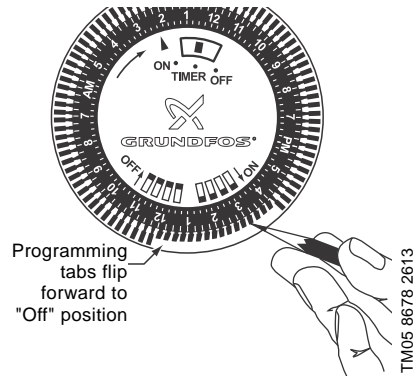

Fig. 9 Setting the timer with programming tab

5. Maintenance and service

Grundfos Comfort System is maintenance free; no service is required.

6. Technical data



Warning
For indoor potable water use only

System	Max storage temperature:	170 °F (76 °C)
	Ambient temperature:	-4 to +175 °F (-20 to +80 °C)
	System type:	Open - residential potable
UP15-10SU7P/TLC	Flow range:	0 - 6.3 gpm (0 - 1.4 m ³ /h)
	Head range:	0 - 5.1 ft (0 - 1.5 m)
	Motor:	Single phase, 60 Hz
	Max. working pressure:	145 psi (10 bar)
	Min. working pressure:	Minimum system pressure
	Max. liquid temperature:	150 °F (66 °C)
	Min. liquid temperature:	36 °F (2 °C)
	Connection:	3/4" M x 3/4" F NPT
Thermal bypass valve	Connections:	1/2" NPSM
Timer	Supply voltage:	115-120 VAC
	Contact rating:	16 amps
Three manual switch modes	ON	Continuous pumping, 24 hrs/day; 7 days/week
	TIMER	Controlled by programming tab settings
	OFF	No pumping
Programming tabs	15-minute increments	
Flex hoses	Connections:	1/2" FNPS x 1/2" FNPS x 12"

6.1 Approvals

ANSI/NSF61
ANSI/NSF372
Comfort Pump
Comfort Valve



UL/cUL
(Electrical Safety)
Comfort Pump



IAPMO (UPC)
Comfort Pump with
Comfort Valve
(Comfort System)



IAPMO (cUPC)
Comfort Valve



7. Fault finding

Fault	Remedy
1. No hot water at faucet or too much hot water on cold water side.	a) To check for proper installation, close cold water angle stop valve below the sink.
	b) Open the cold water faucet.
	c) Water should slowly flow from the cold water faucet until hot water reaches bypass valve.
	d) As the bypass valve closes, the flow from the cold water faucet should gradually decrease to a trickle of water until no water is coming from valve. If not, review bypass valve installation instructions. If necessary, reinstall bypass valve. For installation procedure, see page 4.

8. Disposal

This product or parts of it must be disposed of in an environmentally sound way:

1. Use the public or private waste collection service.
2. If this is not possible, contact the nearest Grundfos company or service workshop.

Subject to alterations.

GRUNDFOS Kansas City

17100 West 118th Terrace
Olathe, Kansas 66061
Phone: (913) 227-3400
Fax: (913) 227-3500

www.grundfos.us

GRUNDFOS Canada

2941 Brighton Road
Oakville, Ontario L6H 6C9 Canada
Phone: +1-905 829 9533
Telefax: +1-905 829 9512

www.grundfos.ca

GRUNDFOS México

Boulevard TLC No. 15
Parque Industrial Stiva Aeropuerto
C.P. 66600 Apodaca, N.L. México
Phone: 011-52-81-8144 4000
Fax: 011-52-81-8144 4010

www.grundfos.mx

L-UP-TL-043

98526174 0914

ECM: 1118650

The name Grundfos, the Grundfos logo, and **be think innovate** are registered trademarks owned by Grundfos Holding A/S or Grundfos A/S, Denmark. All rights reserved worldwide. © Copyright Grundfos Holding A/S