



- Fast quarter turn open or closed operation
- Stainless steel ball and stem
- Positive shut-off
- Two-piece body construction

### Application

- Water-side control of air handling apparatus in ventilation and air-conditioning system
- Water/Steam control in heating systems
- 300:1 rangeability

The dimensions and drilling of end flanges conform to the American cast iron flange standard, Class 150 (ANSI B16.1).

### Technical Data

Media	chilled or hot water, glycol, 250# steam
Flow characteristic	equal percentage
Action	90% rotation valve open CW, valve closed CCW
Sizes	3", 4", 6"
Type of end fittings	flanged

### Materials:

Body	Carbon Steel
Ball	Stainless Steel with Hardened Chrome Plating
Seats	Teflon
Stem	Stainless Steel
Packing	Spring-loaded Teflon

Pressure rating	ANSI 150
Media temp. range	-22°F to 400°F (-30°C to 204°C)
Close-off pressure	150 psig @ 400°F
Maximum differential pressure ( $\Delta P$ )	steam: 100psi water: 150psi

Cv	Valve Nominal Size		Type	Suitable Actuators		
	Inches	DN [mm]	2-way NPT	Spring	Electronic Fail-Safe	Non-Spring
207	3"	80	B6300VB-207	AF		GM AM Series
350	4"	100	B6400VB-350		GK	
507	6"	150	B6600VB-507			GM SY Series



Technical Data		GMB24-3-X1
Control		on/off, floating point
Power supply		24 VAC ± 20% 50/60 Hz 24 VDC ± 10%
Power consumption	running	4 W
	holding	2 W
Transformer sizing		6 VA (class 2 power source)
Electrical connection		3 ft [1m] 18 GA plenum rated cable ½" conduit connector
Overload protection		electronic throughout stroke
Angle of rotation		95°
Direction of rotation		reversible with  switch
Position indication		reflective visual indicator (snap-on)
Running time		150 seconds, constant independent of load
Humidity		5 to 95% RH non-condensing
Ambient temperature		-22°F to 122°F [-30°C to 50°C]
Housing		NEMA 2/IP54 with cable entry down
Housing material		UL94-5V (flammability rating)
Agency listings		cULus according to UL 60730-1A/-2-14, CAN/CSA E60730-1, CSA C22.2 No. 24-93, CE according to 89/336/EEC
Noise level		<45 dB(A)
Quality standard		ISO 9001

### Dimensions with 2-Way Valve

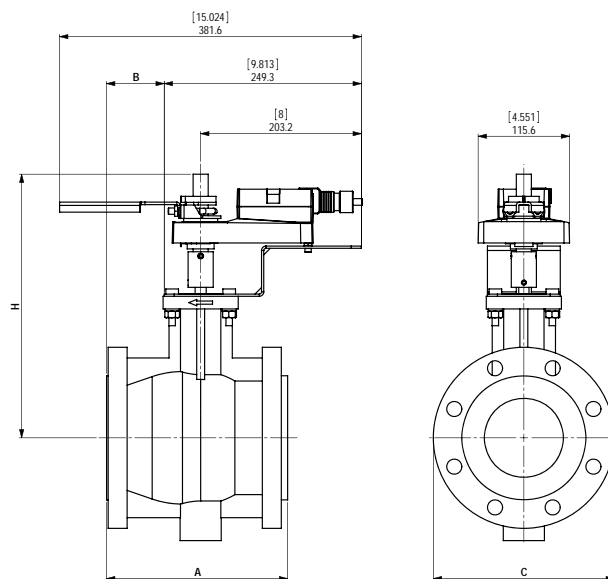

Valve Body	COP	Valve Nominal Size		Dimensions (Inches)			
		Inches	DN [mm]	A	B	C	H
B6400VB-350	150	4"	100	9.00	2.87	9.00	13.13

### Wiring Diagrams

- 1 Provide overload protection and disconnect as required.
- 2 Actuators may be connected in parallel if not mechanically mounted to the same shaft. Power consumption and input impedance must be observed.
- 3 Actuators may also be powered by 24 VDC.
- 4 Position feedback cannot be used with Triac sink controller. The actuator internal common reference is not compatible.
- 5 Control signal may be pulsed from either the Hot (source) or the Common (sink) 24 VAC line.
- 7 Contact closures A & B also can be triacs. A & B should both be closed for triac source and open for triac sink.
- 8 For triac sink the common connection from the actuator must be connected to the hot connection of the controller.

### APPLICATION NOTES

Meets cULus or UL and CSA requirements without the need of an electrical ground connection.

**WARNING Live Electrical Components!**  
During installation, testing, servicing and troubleshooting of this product, it may be necessary to work with live electrical components. Have a qualified licensed electrician or other individual who has been properly trained in handling live electrical components perform these tasks. Failure to follow all electrical safety precautions when exposed to live electrical components could result in death or serious injury.

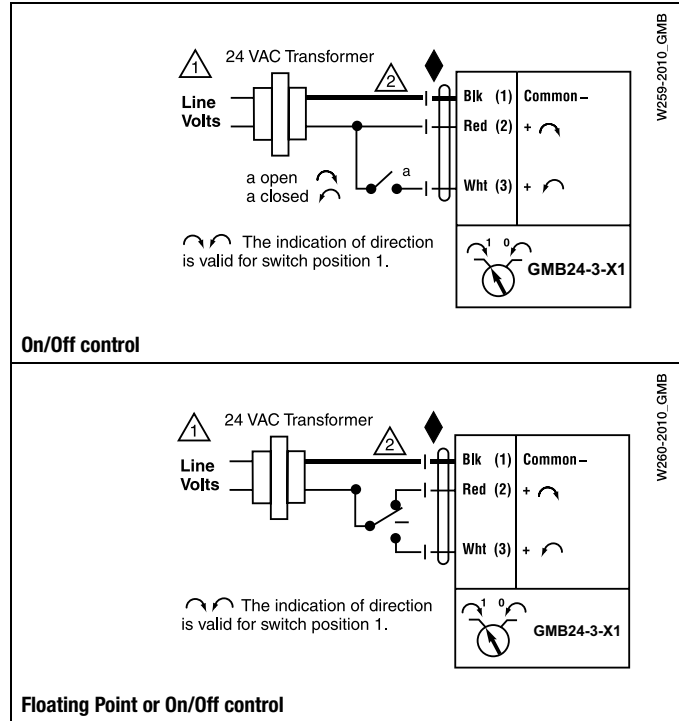

### Piping

The valve should be mounted in a weather-protected area in a location that is within the ambient limits of the actuator. Allow sufficient room for valve with actuator and for service. Allow 6" for cover removal and 12" for complete actuator removal. The assembly can be mounted with the actuator vertical or horizontal in relation to the pipe. The actuators should never be mounted underneath the valve, as condensation can build up and result in a failure of the actuators. Do not reverse flow direction.

## Valve Installation Procedure

### 3", 4" & 6" Valves - Flanged Installation

1. Valve must be in the closed position for installation.
2. **Figure 1 illustrates a flanged valve installation.**
3. Use hex bolts & nuts to secure valve to flange.
4. Ensure proper gaskets are used between the valve flange and pipe flange.
5. Tighten bolts & nuts in alternating opposite sides until completely tightened. Please see torque requirements below. Torque wrench is required.

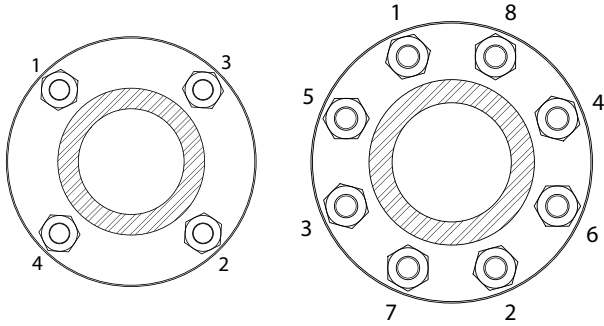

3" Bolt Tightening Sequence

4" & 6" Bolt Tightening Sequence



**WARNING:** Exceeding the Maximum Torque Can Damage the Valve and Void the Warranty!

- 3" ANSI 150 Flange - 65 ft/lbs
- 4" ANSI 150 Flange - 70 ft/lbs
- 6" ANSI 150 Flange - 100 ft/lbs

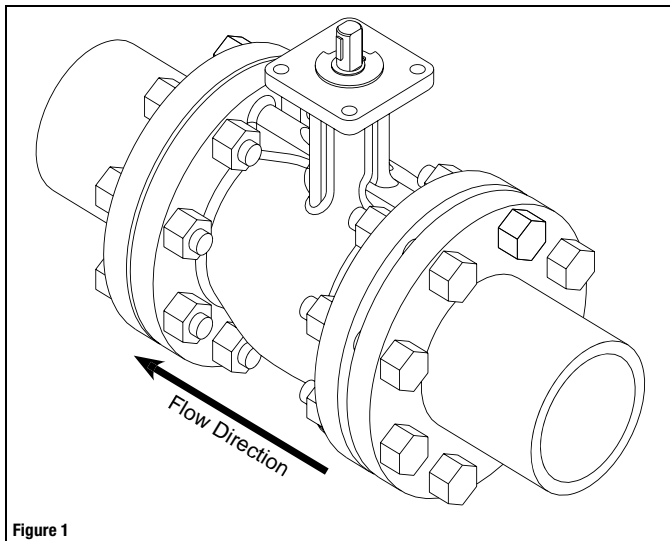

Figure 1

## Seat Replacement Procedure

### 3", 4" & 6" Valves

1. Remove valve from pipe
2. Remove 2 cap retaining washers (1)
3. Using 2 wrenches/flat-head screwdrivers, pry cap assembly (2) out of valve
4. Rotate valve to fully open position
5. Using hands, pull seat (3) out of the valve
6. Replace seat and reverse procedure to reassemble
7. Reinstall valve per installation instructions

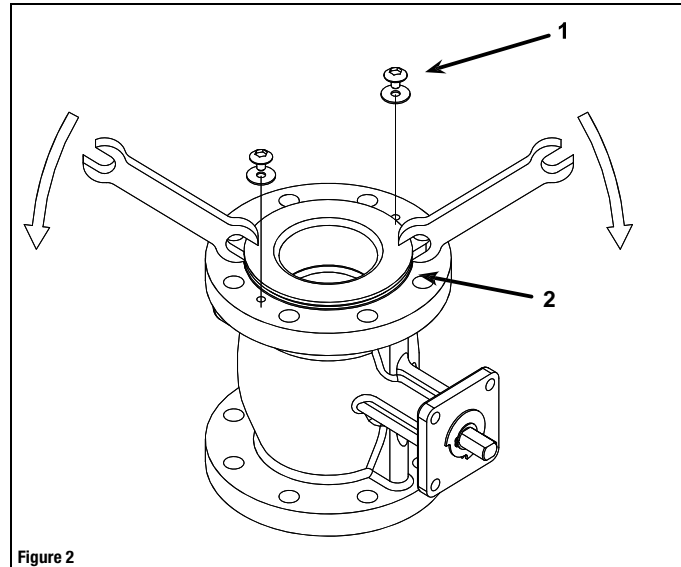

Figure 2

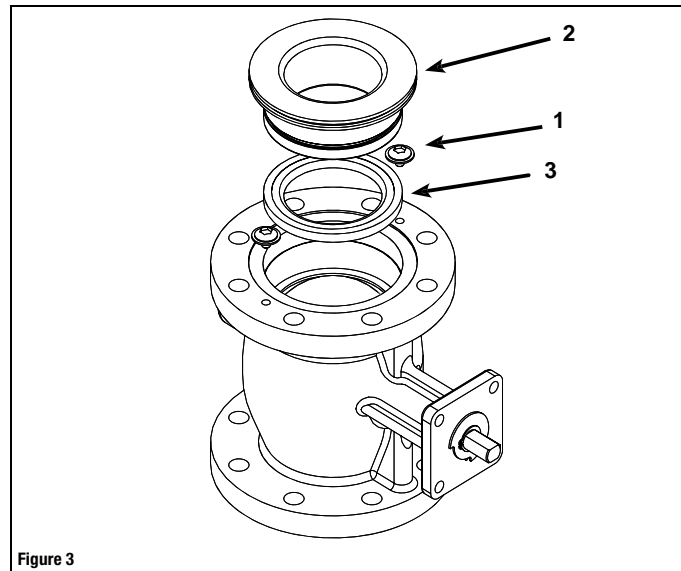

Figure 3