



## Application

This valve is typically used in air handling units on heating or cooling coils, and fan coil unit heating or cooling coils. Some other common applications include Unit Ventilators, VAV box re-heat coils and bypass loops. This valve is suitable for use in a hydronic system with variable or constant flow.

Technical Data	
Service	chilled or hot water, 60% glycol
Flow characteristic	A-port equal percentage B-port modified for constant common port flow
Action	90° rotation
Sizes	½", ¾", 1", 1¼", 1½", 2"
Type of end fitting	NPT female ends
Materials:	
Body	forged brass, nickel plated
Ball	stainless steel
Stem	stainless steel
Seats	PTFE
Characterizing disc	Tefzel®
Packing	2 EPDM O-rings, lubricated
Body Pressure rating	
600 psi*	½" - 1"
400 psi*	1¼" - 2"
Media temp. range	0°F to 212°F [-18°C to 100°C]
Close off pressure	
200 psi	½" - 2"
Maximum differential pressure (ΔP)	30 psi for typical applications
Leakage	0% for A to AB <2.0% for B to AB
C <sub>v</sub> rating	A-port: see product chart for values B-port: 70% of A to AB C <sub>v</sub>

Tefzel® is a registered trademark of DuPont  
\*Per EN 12266-1:2003

## Dimensions

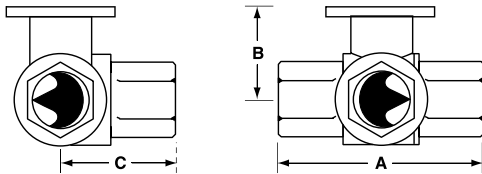

Valve Body	Valve Nominal Size		Dimensions (Inches [mm])		
	Inches	DN [mm]	A	B	C
B307-B311	½"	15	2.41" [61.1]	1.39" [35.2]	1.20" [30.6]
B312-B315	½"	15	2.38" [60.4]	1.72" [43.7]	1.26" [32.1]
B317-B320	¾"	20	2.73" [69.3]	1.81" [45.9]	1.45" [36.8]
B322-B325	1"	25	3.09" [78.4]	1.81" [45.9]	1.56" [39.8]
B329-B331	1¼"	32	3.96" [100.6]	2.21" [56.2]	2.14" [54.3]
B338-B341	1½"	40	4.39" [111.6]	2.45" [62.2]	2.33" [59.1]
B347-B352	2"	50	4.90" [124.5]	2.68" [68.0]	2.60" [66.0]

C <sub>v</sub>	Valve Nominal Size		Type	Suitable Actuators			
	Inches	DN [mm]	3-Way NPT	Non-Spring	Spring		
0.3	½"	15	B307	TR Series	LR Series	NR...N4 Series	
0.46	½"	15	B308				
0.8	½"	15	B309				
1.2	½"	15	B310				
1.9	½"	15	B311				
3	½"	15	B312				
4.7	½"	15	B313				
10	½"	15	B315*				
4.7	¾"	20	B317				TF Series
7.4	¾"	20	B318				
24	¾"	20	B320*				
7.4	1"	25	B322				
10	1"	25	B323				
30	1"	25	B325*				
10	1¼"	32	B329	LF Series			
19	1¼"	32	B330				
25	1¼"	32	B331				
19	1½"	40	B338				
29	1½"	40	B339				
37	1½"	40	B340				
46	1½"	40	B341				
29	2"	50	B347		AR Series		
37	2"	50	B348				
46	2"	50	B349				
57	2"	50	B350				
68	2"	50	B351				
83	2"	50	B352	AR...N4 Series			
					AF Series		

\*Models without characterizing disc

## Flow Patterns

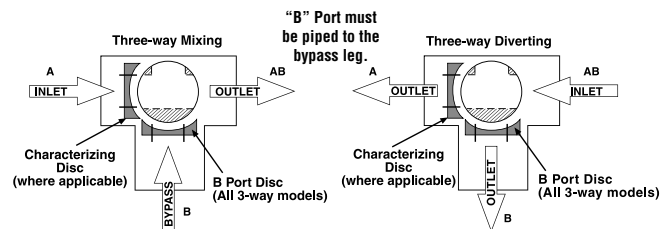

# LRX24-MFT95 Actuators, 0 to 135 Ω, Proportional

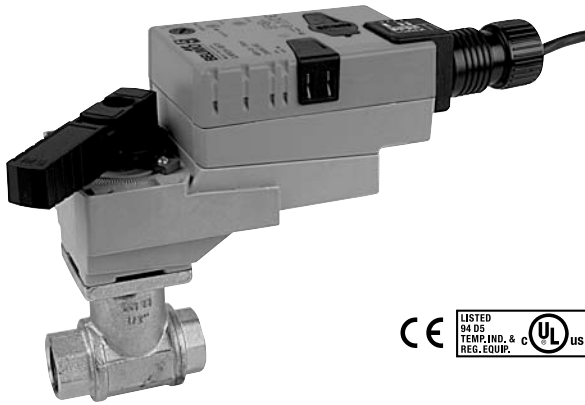

## Models

LRX24-MFT95

Technical Data	
Power supply	24 VAC ± 20% 50/60 Hz 24 VDC ± 10%
Power consumption	running 2 W holding 1.2 W
Transformer sizing	5 VA (Class 2 power source)
Electrical connection	½" conduit connector 18 GA plenum rated cable □ 3 ft [1m] □ 10 ft [3m] □ 16 ft [5m]
Overload protection	electronic throughout 0 to 95° rotation
Operating range WRB	0 to 135 Ω Honeywell Electronic Series 90, 0 to 135 Ω Input
Feedback output U	2 to 10 Vdc, 0.5mA max
Input impedance	100 kΩ (0.1 mW)
Angle of rotation	90°, adjustable with mechanical stop electronically variable
Direction of rotation	reversible with ↻/↻ switch
Position indication	handle
Manual override	external push button
Running time	150 seconds (default) Variable (35 to 150 secs)
Humidity	5 to 95% RH non-condensing (EN 60730-1)
Ambient temperature	-22°F to 122°F [-30°C to 50°C]
Storage temperature	-40°F to 176°F [-40°C to 80°C]
Housing	NEMA 2/IP54
Housing material	UL94-5VA
Agency listings†	cULus according to UL 60730-1A/-2-14, CAN/CSA E60730-1:02, CE according to 2004/108/EC and 2006/95/EC for line voltage and/or -S versions
Noise level	<35 dB(A)
Quality standard	ISO 9001

†Rated Impulse Voltage 800V, Type of action 1, Control Pollution Degree 3.

## Dimensions with 2-Way Valve

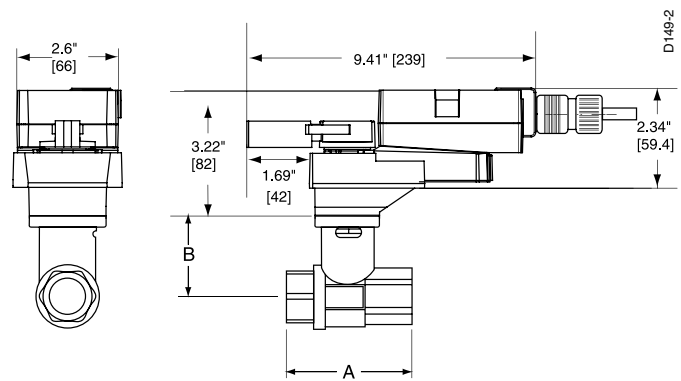

Valve Body	Valve Nominal Size		Dimensions (Inches [mm])	
	Inches	DN [mm]	A	B
B207-B211	½"	15	2.41" [61.1]	1.39" [35.2]
B212-B215	½"	15	2.38" [60.4]	1.72" [43.7]
B217-B220	¾"	20	2.73" [69.3]	1.81" [45.9]
B222-B225	1"	25	3.09" [78.4]	1.81" [45.9]
B229-B230	1¼"	32	3.72" [94.6]	1.81" [45.9]

## Dimensions with 3-Way Valve

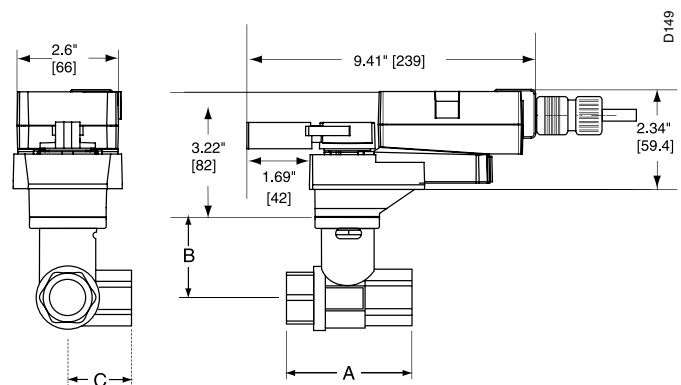

Valve Body	Valve Nominal Size		Dimensions (Inches [mm])		
	Inches	DN [mm]	A	B	C
B307-B311	½"	15	2.41" [61.1]	1.39" [35.2]	1.20" [30.6]
B312-B315	½"	15	2.38" [60.4]	1.72" [43.7]	1.26" [32.1]
B317-B320	¾"	20	2.73" [69.3]	1.81" [45.9]	1.45" [36.8]
B322-B325	1"	25	3.09" [78.4]	1.81" [45.9]	1.56" [39.8]

L30034 - 07/09 - Subject to change. © Belimo Aircontrols (USA), Inc.

### Wiring Diagrams

#### INSTALLATION NOTES

- 21 Provide overload protection and disconnect as required.
- 22 Actuators and controller must have separate transformers.
- 23 Consult controller instruction data for more detailed information.
- 24 Resistor value depends on the type of controller and the number of actuators. No resistor is used for one actuator. Honeywell® resistor kits may also be used.
- 25 To reverse control rotation, use the reversing switch. 2524232221

**WARNING Live Electrical Components!** During installation, testing, servicing and troubleshooting of this product, it may be necessary to work with live electrical components. Have a qualified licensed electrician or other individual who has been properly trained in handling live electrical components perform these tasks. Failure to follow all electrical safety precautions when exposed to live electrical components could result in death or serious injury.

L30034 - 07/09 - Subject to change. © Belimo Aircontrols (USA), Inc.

Switch A	Switch B	Damper Position
		Damper Open
		Damper Closed

The direction of rotation switch is set so that the fail safe position and the position of the damper is closed with no signal at wire R.

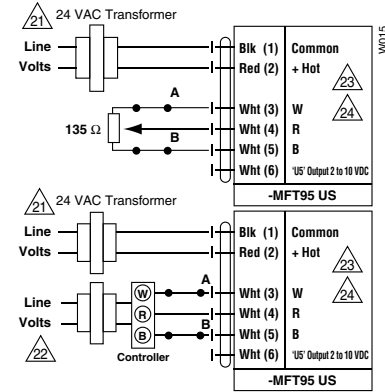

#### Override

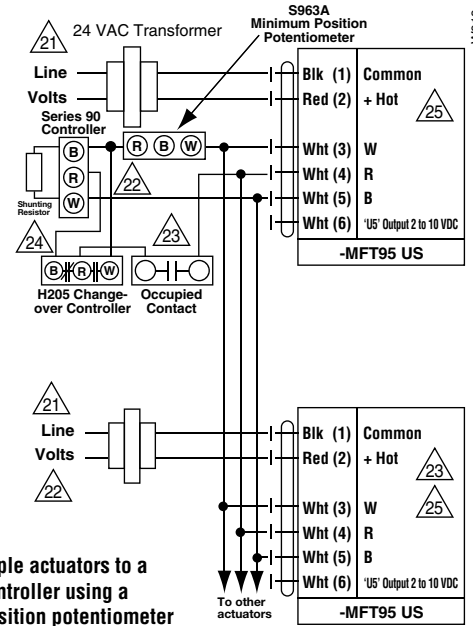

#### Wiring multiple actuators to a Series 90 controller using a minimum position potentiometer

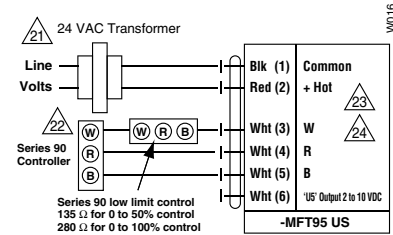

#### Low Limit Control

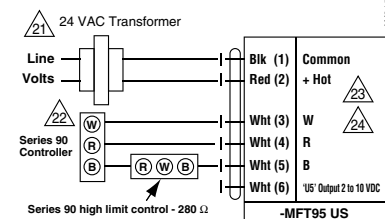

#### High Limit Control