

B2...VB Series, 2-Way, VBall Control Valve

Carbon Steel Body, Hardened Chrome Plated, Stainless Steel Ball and Stem



- Fast quarter turn open or closed operation
- Stainless steel ball and stem
- Positive shut-off
- Two-piece body construction

Application

- Water-side control of air handling apparatus in ventilation and air-conditioning system
- Water/Steam control in heating systems
- 300:1 rangeability

The dimensions and drilling of end flanges conform to the American cast iron flange standard, Class 150 (ANSI B16.1).

Technical Data

Media	chilled or hot water, glycol, 250# steam
Flow characteristic	equal percentage
Action	90% rotation valve open CW, valve closed CCW
Sizes	1", 1½", 2"
Type of end fittings	NPT

Materials:

Body	Carbon Steel
Ball	Stainless Steel with Hardened Chrome Plating
Seats	Teflon
Stem	Stainless Steel
Packing	Spring-loaded Teflon

Pressure rating	ANSI 300
Media temp. range	-22°F to 400°F (-30°C to 204°C)
Close-off pressure	150 psig @ 400°F
Maximum differential pressure (ΔP)	steam: 100psi water: 150psi

Cv	Valve Nominal Size		Type	Suitable Actuators		
	Inches	DN [mm]	2-way NPT	Spring	Non-Spring	
24	1"	25	B2100VB-024	NF Series	AM Series	SY Series
55	1½"	40	B2150VB-055			
77	2"	50	B2200VB-077	AF Series		

AMB(X)24-3-X1

On/Off, Floating Point



Technical Data		AMB(X)24-3-X1
Control		on/off, floating point
Power supply		24 VAC ± 20% 50/60 Hz 24 VDC ± 10%
Power consumption	running	2.5 W
	holding	0.2 W
Transformer sizing		5.5 VA (class 2 power source)
Electrical connection		½" conduit connector
AMB24-3-X1		3 ft, 18 GA plenum rated cable
Overload protection		electronic throughout 0° to 95° rotation
Input impedance		600 Ω
Angle of rotation		max 95°, adjustable with mechanical stop
Torque		180 in-lb [20 Nm]
Direction of rotation		reversible with switch
Position indication		reflective visual indicator (snap-on)
Manual override		external push button
Running time		95 seconds, constant independent of load
Humidity		5 to 95% RH non-condensing (EN 60730-1)
Ambient temperature		-22° F to 122° F [-30° C to 50° C]
Storage temperature		-40° F to 176° F [-40° C to 80° C]
Housing		NEMA type 2/IP54
Housing material		UL94-5VA
Agency listings		cULus according to UL 60730-1/-2-14, CAN/CSA C22.2 No. 24 certified, CE according to 73/23/EEC
Noise level		<45 db(A)
Servicing		maintenance free
Quality standard		ISO 9001

Dimensions with 2-Way Valve

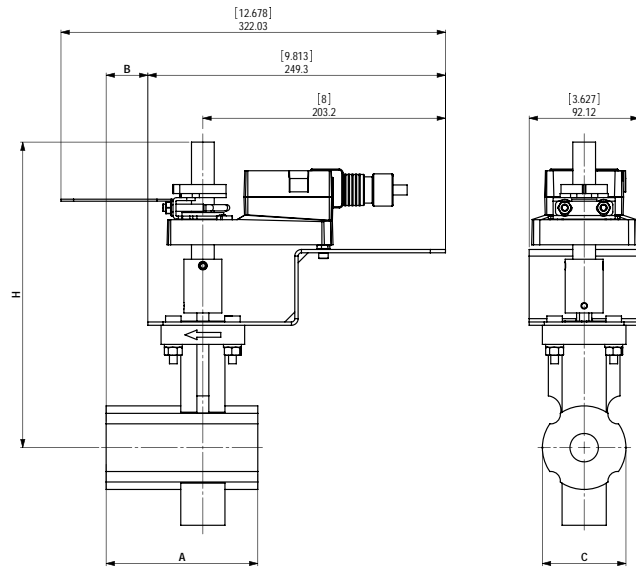

Valve Body	COP	Valve Nominal Size		Dimensions (Inches)			
		Inches	DN [mm]	A	B	C	H
B2100VB-024	150	1"	25	5.00	1.37	2.75	10.07
B2150VB-055	150	1½"	40	7.00	2.51	3.42	10.47
B2200VB-077	150	2"	50	7.00	2.51	3.93	11.14
B6300VB-207	150	3"	80	8.00	2.64	7.48	12.05

M40025 - 05/10 - Subject to change. © Belimo Aircontrols (USA), Inc.

Wiring Diagrams

✂️ INSTALLATION NOTES

- 1 Provide overload protection and disconnect as required.
- 2 **CAUTION Equipment damage!**
Actuators may be connected in parallel.
Power consumption and input impedance must be observed.
- 3 Actuators may also be powered by 24 VDC.
- 5 Only connect common to neg. (-) leg of control circuits.

📄 APPLICATION NOTES

- ◆ Meets cULus or UL and CSA requirements without the need of an electrical ground connection.
- ⚠️ **WARNING Live Electrical Components!**
During installation, testing, servicing and troubleshooting of this product, it may be necessary to work with live electrical components. Have a qualified licensed electrician or other individual who has been properly trained in handling live electrical components perform these tasks. Failure to follow all electrical safety precautions when exposed to live electrical components could result in death or serious injury.

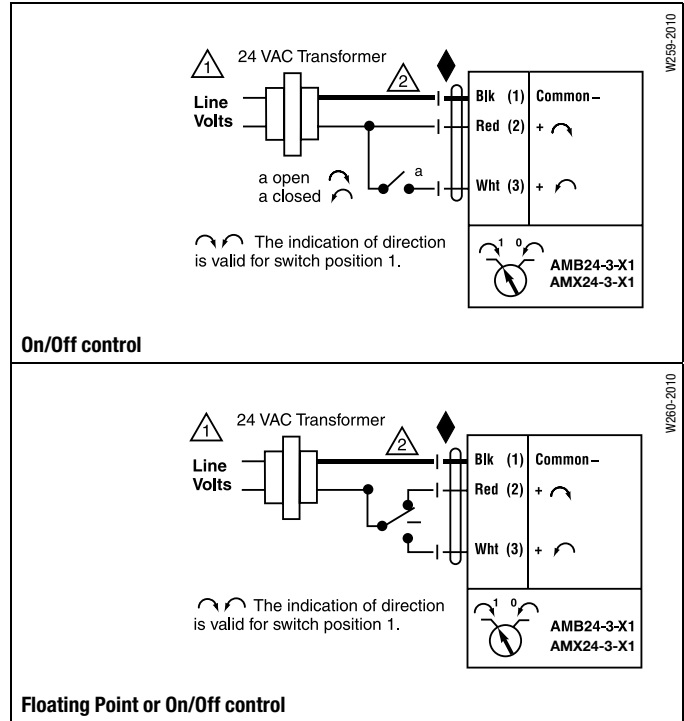

Piping

The valve should be mounted in a weather-protected area in a location that is within the ambient limits of the actuator. Allow sufficient room for valve with actuator and for service. Allow 6" for cover removal and 12" for complete actuator removal. The assembly can be mounted with the actuator vertical or horizontal in relation to the pipe. The actuators should never be mounted underneath the valve, as condensation can build up and result in a failure of the actuators. Do not reverse flow direction.

Valve Installation Procedure

3", 4" & 6" Valves - Flanged Installation

1. Valve must be in the closed position for installation.
2. **Figure 1 illustrates a flanged valve installation.**
3. Use hex bolts & nuts to secure valve to flange.
4. Ensure proper gaskets are used between the valve flange and pipe flange.
5. Tighten bolts & nuts in alternating opposite sides until completely tightened. Please see torque requirements below. Torque wrench is required.

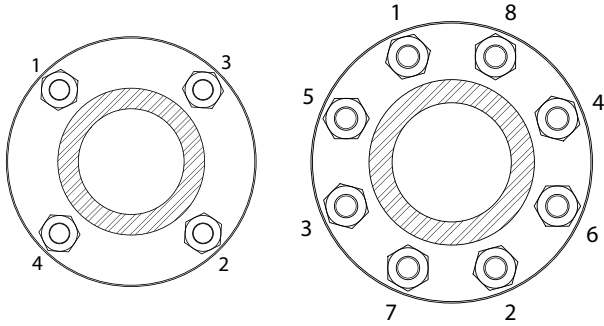

3" Bolt Tightening Sequence

4" & 6" Bolt Tightening Sequence



WARNING: Exceeding the Maximum Torque Can Damage the Valve and Void the Warranty!

- 3" ANSI 150 Flange - 65 ft/lbs
- 4" ANSI 150 Flange - 70 ft/lbs
- 6" ANSI 150 Flange - 100 ft/lbs

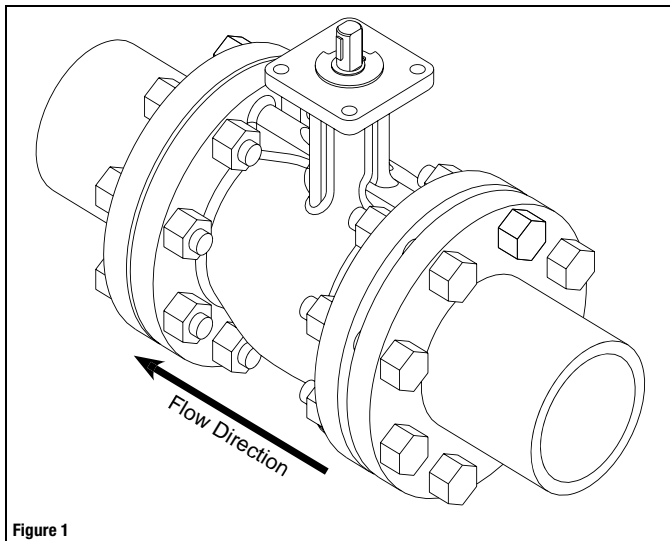

Figure 1

Seat Replacement Procedure

3", 4" & 6" Valves

1. Remove valve from pipe
2. Remove 2 cap retaining washers (1)
3. Using 2 wrenches/flat-head screwdrivers, pry cap assembly (2) out of valve
4. Rotate valve to fully open position
5. Using hands, pull seat (3) out of the valve
6. Replace seat and reverse procedure to reassemble
7. Reinstall valve per installation instructions

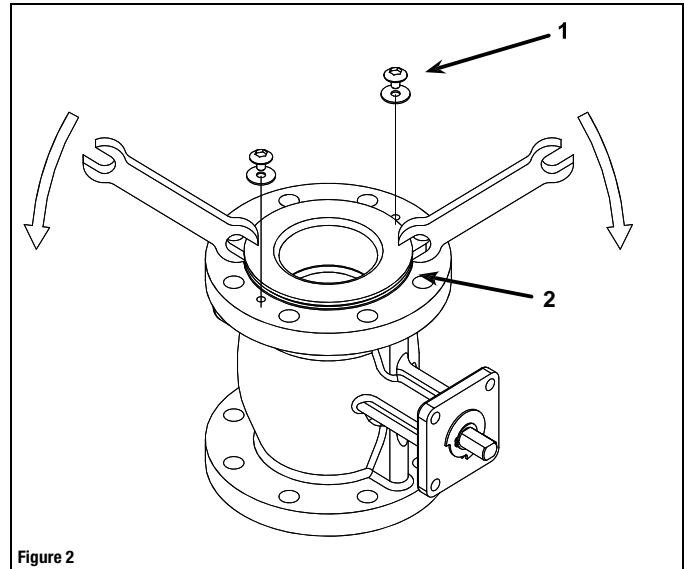

Figure 2

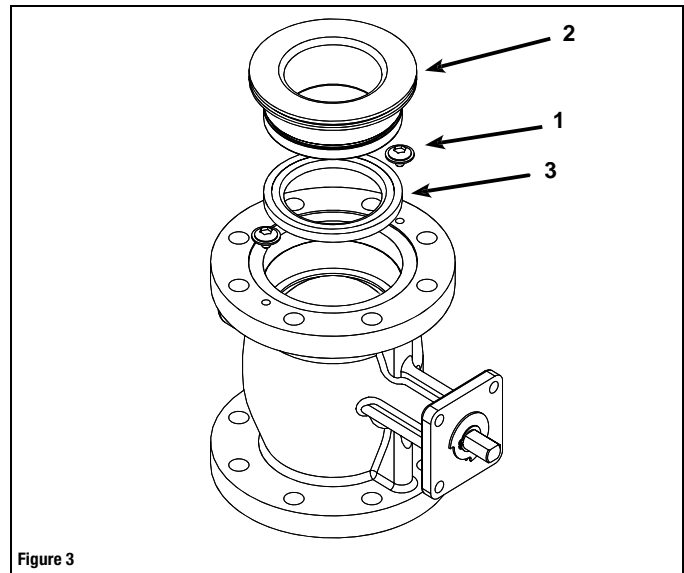

Figure 3