

# B2 Series, 2-Way, Characterized Control Valve Stainless Steel Ball and Stem



Technical Data	
Service	chilled or hot water, 60% glycol
Flow characteristic	A-port equal percentage
Action	90° rotation
Sizes	½", ¾", 1", 1¼", 1½", 2", 2½", 3"
Type of end fitting	NPT female ends
Materials:	
Body	forged brass, nickel plated
Ball	stainless steel
Stem	stainless steel
Seats	PTFE
Characterizing disc	Tefzel®
Packing	2 EPDM O-rings, lubricated
Body Pressure rating	
600 psi*	½" - 1¼" (B230)
400 psi*	1¼" (B231) - 3"
Media temp. range	0°F to 212°F [-18°C to 100°C]
Close off pressure	
200 psi	½" - 2" (B250)
100 psi	2" (B251) - 3"
Maximum differential pressure (ΔP)	30 psi for typical applications
Leakage	0% for A to AB
C <sub>v</sub> rating	A-port: see product chart for values

Tefzel® is a registered trademark of DuPont  
\*Per EN 12266-1:2003

## Dimensions

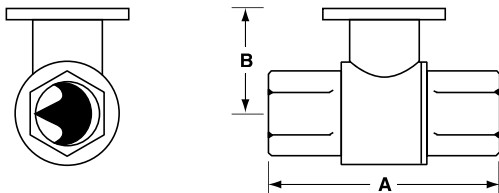

2WayValve-B207-B220

Valve Body	Valve Nominal Size		Dimensions (Inches [mm])	
	Inches	DN [mm]	A	B
B207-B211	½"	15	2.41" [61.1]	1.39" [35.2]
B212-B215	½"	15	2.38" [60.4]	1.72" [43.7]
B217-B220	¾"	20	2.73" [69.3]	1.81" [45.9]
B222-B225	1"	25	3.09" [78.4]	1.81" [45.9]
B229-B230	1¼"	32	3.72" [94.6]	1.81" [45.9]
B231-B232	1¼"	32	3.72" [94.6]	1.98" [50.4]
B238-B240	1½"	40	3.88" [98.5]	1.98" [50.4]
B248-B250	2"	50	4.21" [107.0]	2.21" [56.2]
B251-B254	2"	50	4.93" [125.2]	2.68" [68.0]
B261-B265	2½"	65	5.55" [140.9]	2.68" [68.0]
B277-B280	3"	80	5.82" [147.9]	2.68" [68.0]

## Application

This valve is typically used in air handling units on heating or cooling coils, and fan coil unit heating or cooling coils. Some other common applications include Unit Ventilators, VAV box re-heat coils and bypass loops. This valve is suitable for use in a hydronic system with variable flow.

C <sub>v</sub>	Valve Nominal Size		Type	Suitable Actuators			
	Inches	DN [mm]	2-Way NPT	Non-Spring	Spring		
0.3	½"	15	B207	TR Series	LR Series	NR...M4 Series	TF Series
0.46	½"	15	B208				
0.8	½"	15	B209				
1.2	½"	15	B210				
1.9	½"	15	B211				
3	½"	15	B212				
4.7	½"	15	B213				
7.4	½"	15	B214				
10	½"	15	B215*				
4.7	¾"	20	B217				
7.4	¾"	20	B218				
10	¾"	20	B219				
24	¾"	20	B220*				
7.4	1"	25	B222				
10	1"	25	B223				
19	1"	25	B224				
30	1"	25	B225*				
10	1¼"	32	B229				
19	1¼"	32	B230*				
25	1¼"	32	B231				
37	1¼"	32	B232*				
19	1½"	40	B238				
29	1½"	40	B239				
37	1½"	40	B240*				
29	2"	50	B248				
46	2"	50	B249				
57	2"	50	B250*				
65	2"	50	B251				
85	2"	50	B252				
120	2"	50	B253				
240	2"	50	B254*				
60	2½"	65	B261				
75	2½"	65	B262				
110	2½"	65	B263				
150	2½"	65	B264				
210	2½"	65	B265*				
70	3"	80	B277				
130	3"	80	B278				
170	3"	80	B280*				

\*Models without characterizing disc

## Flow Patterns

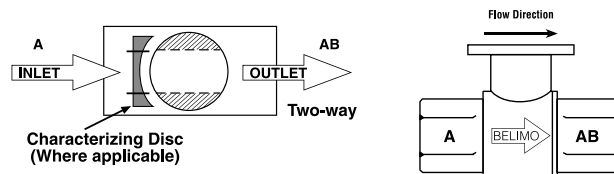

L30034 - 07/09 - Subject to change. © Belimo Aircontrols (USA), Inc.



**MFT**



## Models

TF24-MFT US

Technical Data		
Control		MFT
Power supply		24 VAC ± 20% 50/60 Hz 24 VDC ± 10%
Power consumption	running	2.5 W
	holding	1.0 W
Transformer sizing		4 VA (class 2 power source)
Electrical connection		½" conduit connector 3 ft [1m], 18 GA plenum rated cable
Overload protection		electronic throughout 0° to 95° rotation
Operating range Y*		2 to 10 VDC, 4 to 20 mA (default) Variable (VDC, PWM, Floating Point, On/Off)
Feedback output U*		2 to 10 VDC, 0.5 mA max
Input impedance		100 kΩ for 2 to 10 VDC (0.1 mA)
		500 Ω for 4 to 20 mA
		1500 Ω for PWM, floating point and on-off control
Mechanical angle of rotation*		95°
Angle of Rotation Adaptation*		Off (Default)
Direction of rotation	spring	reversible with CW/CCW mounting
	motor	reversible with built-in  switch
Position indication		visual indicator, 0° to 95°
Override control*		Min. (Min Position) = 0% - ZS (Mid. Position) = 50% - Max. (Max. Position) = 100%
Running time	motor*	95 sec constant independent of load
	spring	<25 sec @ -4°F to 122°F [-20°C to 50°C] <60 sec @ -22°F [-30°C]
Humidity		5 to 95% RH, non-condensing
Ambient temperature		-22 to 122° F (-30 to 50° C)
Storage temperature		-40 to 176° F (-40 to 80° C)
Housing		NEMA 2/IP42
Housing material		UL 94-5VA
Agency listings†		cULus according to UL 60730-1A/-2-14, CAN/CSA E60730-1:02, CE according to 2004/108/EC and 2006/95/EC for line voltage and/or -S versions
Noise level (max)	running	<35 dB (A)
	spring return	<65 dB (A)
Quality standard		ISO 9001

\* Variable when configured with MFT options

† Rated impulse voltage 0.8 kV, Control pollution degree 3, Type of action 1.AA.

## Dimensions with 2-Way Valve

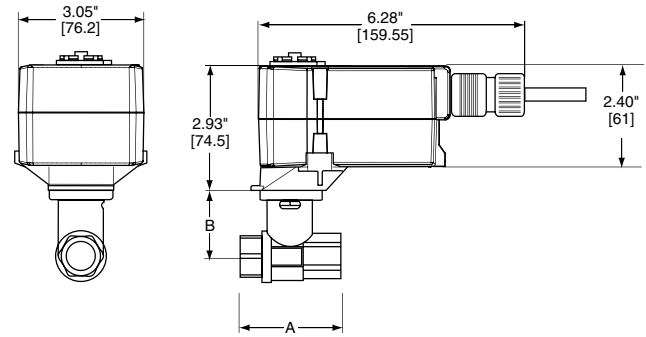

D094

Valve Body	Valve Nominal Size		Dimensions (Inches [mm])	
	Inches	DN [mm]	A	B
B207-B211	½"	15	2.41" [61.1]	1.39" [35.2]
B212-B215	½"	15	2.38" [60.4]	1.72" [43.7]
B217-B220	¾"	20	2.73" [69.3]	1.81" [45.9]

## Dimensions with 3-Way Valve

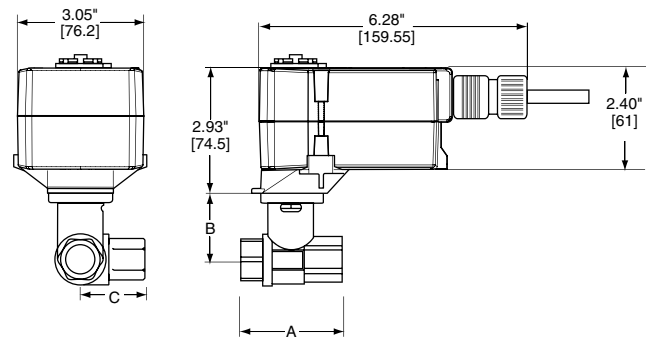

D095

Valve Body	Valve Nominal Size		Dimensions (Inches [mm])		
	Inches	DN [mm]	A	B	C
B307-B311	½"	15	2.41" [61.1]	1.39" [35.2]	1.20" [30.6]
B312-B315	½"	15	2.38" [60.4]	1.72" [43.7]	1.26" [32.1]
B317-B320	¾"	20	2.73" [69.3]	1.81" [45.9]	1.45" [36.8]

### Wiring Diagrams

#### INSTALLATION NOTES

- 1 Provide overload protection and disconnect as required.
- 2 **CAUTION Equipment damage!**  
Actuators may be connected in parallel.  
Power consumption and input impedance must be observed.
- 3 Actuators may also be powered by 24 VDC.
- 4 ZG-R01 may be used.

**WARNING Live Electrical Components!**  
During installation, testing, servicing and troubleshooting of this product, it may be necessary to work with live electrical components. Have a qualified licensed electrician or other individual who has been properly trained in handling live electrical components perform these tasks. Failure to follow all electrical safety precautions when exposed to live electrical components could result in death or serious injury.

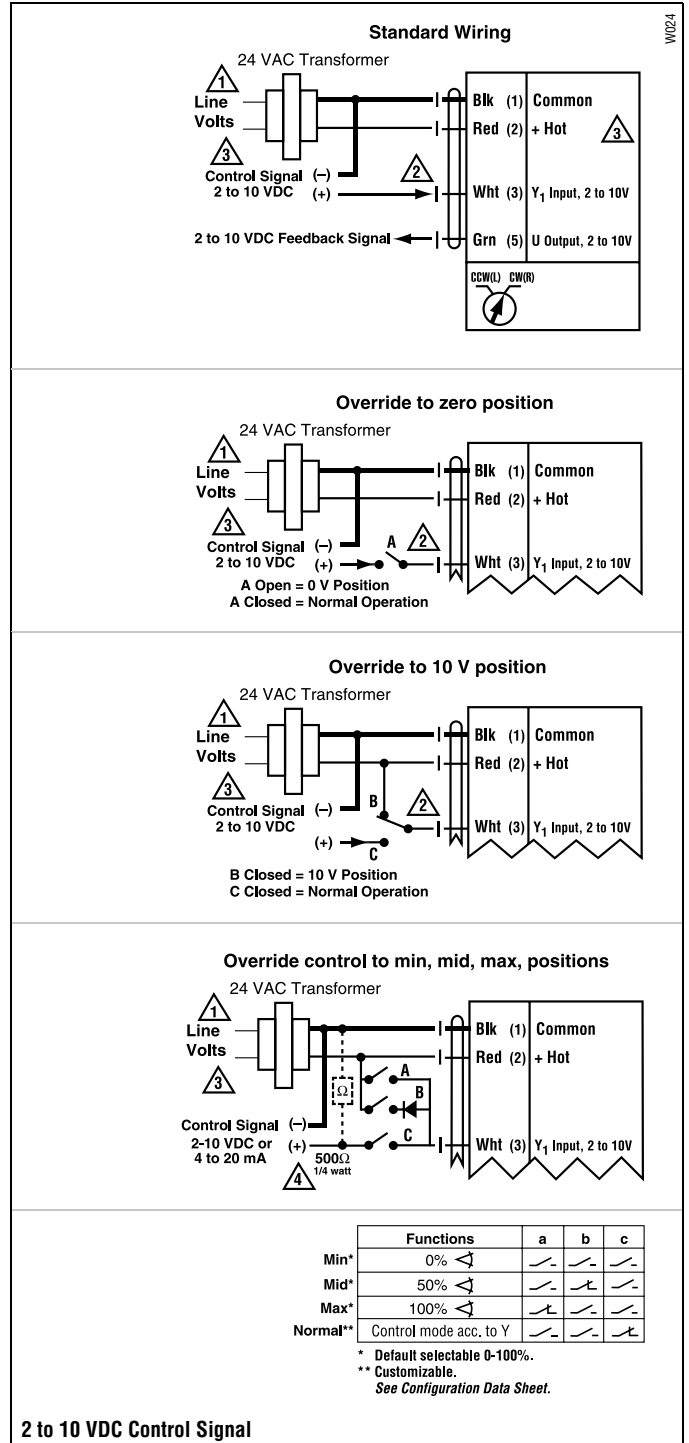
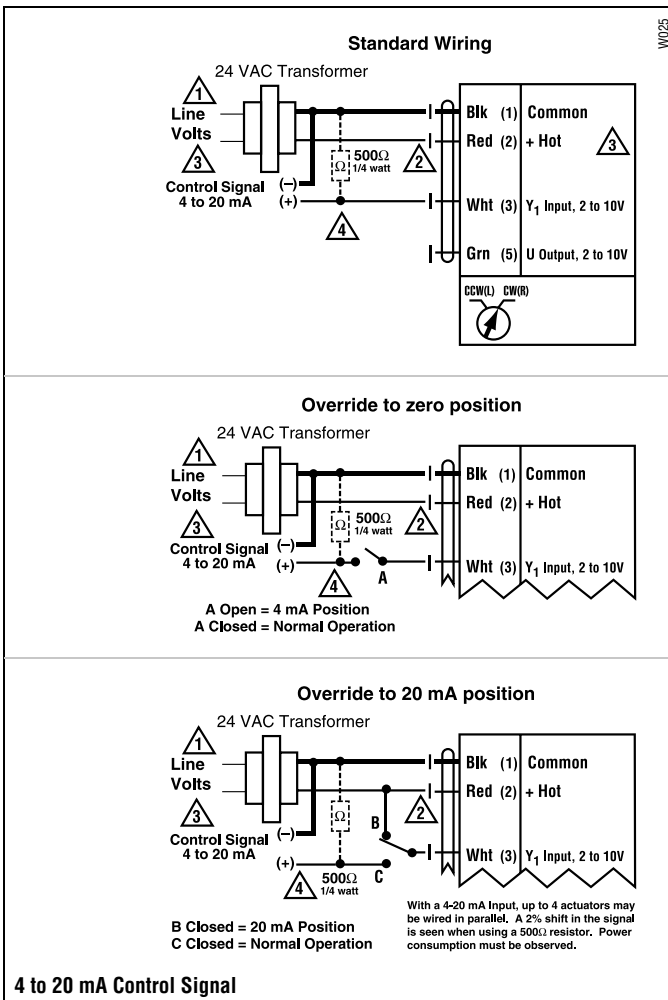

L30034 - 07/09 - Subject to change. © Belimo Aircontrols (USA), Inc.