

WDWS-EN3

WWS-EN3

Getting Started

- Plan where you will mount each receiver and transmitter.
 - Avoid transmitting along a length of wall, sharp angles and large obstructions.
 - Avoid mounting inside a metal enclosure.
 - Typical range is 100' line of sight.
- Link devices to each other before installing. See linking instructions (per application) on following pages.
 - All RIBs must be powered during Link.
- RIBWxxxB-EN3 is both a transmitter and a receiver.
- RIBWxxC-EN3 is only a receiver.
- Linking a RIB with another RIB puts the pair in Bi-directional mode.
- PHC Gateway Controller can also link with a RIB and be Bi-directional.
- Relay output state is saved at power loss. Relay output is restored when power is recovered. (Exception: RIBW24B-EN3 will not save last state when powered from 24Vdc).
- Each Relay can be Linked to up to 30 transmitters of any combination.

902 MHz Model	Power Input (Vac)	Contact Rating (A)	Transmission Source	EEP
RIBW24B-EN3	24 ac/dc	20	Dry-Contact	A5-30-02
RIBW01B-EN3	120	20	Dry-Contact	A5-30-02
RIBW208-EN3	208	20	Dry-Contact	A5-30-02
RIBW240B-EN3	240	20	Dry-Contact	A5-30-02
RIBW277B-EN3	277	20	Dry-Contact	A5-30-02
RIBW01C-EN3	120	5	NA	A5-30-02
RIBW02C-EN3	208-277	5	NA	A5-30-02
WDWS-EN3	None	NA	Contact Closure	D5-00-01
WWS-EN3	None	NA	Button Press	F6-02-02

Compatible Devices from other Manufacturers

Device	EEP
PHC Gateway Controller	A5-38-08
Keycard	F6-02-02
Occupancy Sensor	A5-07-01

Building Automation Applications

Uni-directional Mode: Only one of the RIBs must transmit. Two RIBWxxxB-EN3 or one RIBWxxxB-EN3 and one RIBWxxC-EN3.

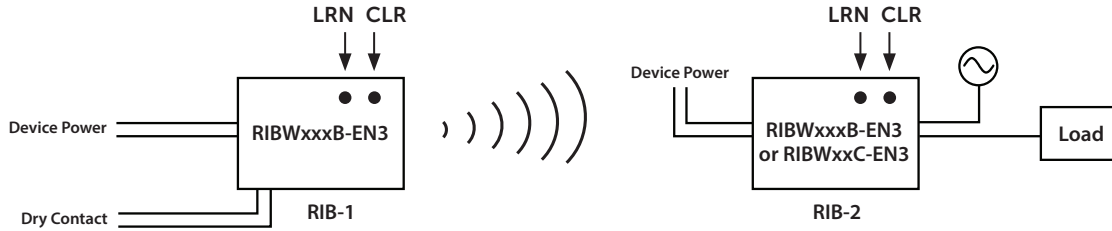

- Only one RIB is the transmitter while the other is the receiver.
- Transmitter RIB Dry contact closure will transmit a relay ON command; dry contact open will transmit a relay OFF command.
- Re-transmits dry contact input state every 70-140 seconds.
- Optional modes: Repeater, Alarm (see pages 4)

Uni-directional Link Procedure

1. Apply power to both RIB's.
2. Get RIB-1 in Learn mode by pressing the LRN button for ½ second. (LED will blink).
3. On RIB-2 hold LRN button for 3 seconds to transmit a Teach telegram.
 - a. LED on RIB-1 will stay ON for 4 seconds to acknowledge and then transmit a Teach telegram.
 - b. LED on RIB-2 will stay ON for 4 seconds to acknowledge the Teach telegram from RIB-1.

Note: To clear memory, hold CLR button for 3 seconds.

Bi-directional Mode: Two RIBWxxxB- or one RIBWxxB-EN3 and a PHC Gateway Controller

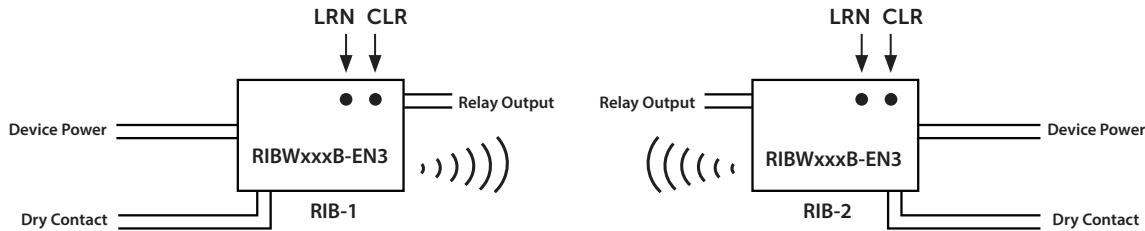

- Both devices must be able to receive and transmit.
- Dry contact closure will transmit a relay ON command; dry contact open will transmit a relay OFF command.
- RIBWxxB-EN3 Re-transmits dry contact input state every 70-140 seconds.
- Optional modes: Repeater, Alarm (see pages 4)

Bi-directional Link Procedure

1. Apply power to both RIB's.
2. Get RIB-1 in Learn mode by pressing the LRN button for ½ second. (LED will blink).
3. On RIB-2, hold LRN button 3 seconds to transmit a Teach telegram.
 - a. LED on RIB-1 will stay ON for 4 seconds to acknowledge and then transmit a Teach telegram.
 - b. LED on RIB-2 will stay ON for 4 seconds to acknowledge the Teach telegram from RIB-1.

Note: To clear memory, hold CLR button for 3 seconds.

Lighting Applications

Simple Lighting Control: *RIBWxxxB-EN3* or *RIBWxxC-EN3* and *WWS-EN3*

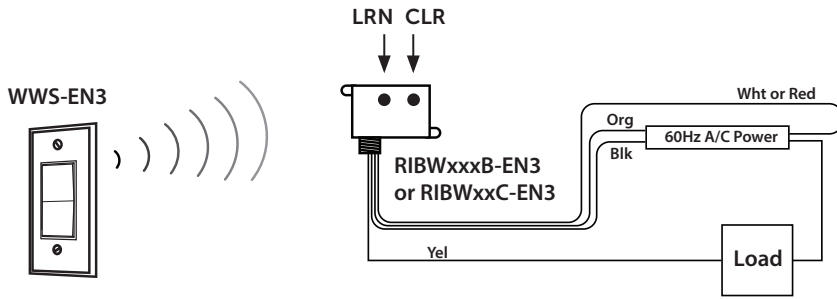

A. Rocker Mode

- Relay activates when Rocker ON is pressed; relay deactivates when Rocker OFF is pressed.
- Optional modes: Repeater (see page 4)

Rocker Mode Link Procedure

1. Apply power to RIB.
2. Press and hold LRN button on RIB for ½ second. LED will blink slowly.
3. Press and release the button on the switch you are learning three times quickly.
4. LED on RIB will stay ON for 4 seconds indicating telegram reception.
5. To learn another switch, repeat steps 2-4.

B. Momentary Mode

- Relay activates while switch is pressed (card inserted, for example) and deactivates when switch is released.
- Optional modes: Repeater (see page 4)

Momentary Mode Link Procedure

1. Apply power to RIB.
2. Press and hold LRN button on RIB for ½ second. LED will blink slowly.
3. Press and hold LRN button on RIB for 3 seconds until LED pattern changes to FLASH, FLASH, OFF (2 flashes).
4. Press and release the button on the switch you are learning three times quickly.
5. LED on RIB will stay ON for 4 seconds indicating telegram reception.
6. To learn another switch, repeat steps 2-5.

C. Toggle Mode

- Each press and release of the switch causes the relay to change state.
- Optional modes: Repeater (see page 4)

Toggle Mode Link Procedure

1. Apply power to RIB.
2. Press and hold LRN button on RIB for ½ second. LED will blink slowly.
3. Press and hold LRN button on RIB for 3 seconds until LED pattern changes to FLASH, FLASH, OFF (2 flashes).
4. Press and hold LRN button on RIB for 3 seconds until LED pattern changes again, to FLASH, FLASH, FLASH, OFF (3 flashes).
5. Press and release the button on the switch you are learning three times quickly.
6. LED on RIB will stay ON for 4 seconds indicating telegram reception.
7. To learn another switch, repeat steps 2-6.

Occupancy Detection

Continued on Page 4

A. Manual ON–Auto OFF: *RIB receiving from both an Occupancy Sensor and a wall switch WWS-EN3*

- Relay activates when Rocker ON is pressed. Relay deactivates when Rocker OFF is pressed or 30 minutes after last detection of Occupancy.
- It may take up to 2 minutes for the RIB to respond to the Occupancy Sensor immediately following Link.
- Optional modes: Repeater (see page 4)

Manual ON – Auto OFF Learn Procedure

1. Be sure the Occupancy Sensor is charged
2. Apply power to RIB.
3. Press and hold LRN button on RIB for ½ second. LED will blink slowly.
4. Trigger a Teach telegram from the Occupancy Sensor per Manufacturer's instructions.
5. LED on RIB will stay ON for 4 seconds acknowledging telegram reception.
6. Press and hold LRN button on RIB for ½ second. LED will blink slowly.
7. Press and release rocker switch three times quickly.
8. LED on RIB will stay ON for 4 seconds acknowledging telegram reception.
9. To learn another switch, repeat steps 6-8.

B. Auto On: RIB and an Occupancy Sensor

- Relay activates when occupancy is detected and deactivates 30 minutes after last detection of occupancy.
- It may take up to 2 minutes for the RIB to respond to the Occupancy Sensor immediately following Link.
- Optional modes: Repeater (see page 4)

Occupancy Sensor Only Learn Procedure

1. Charge the Occupancy Sensor per Manufacturer's instructions.
2. Apply power to RIB.
3. Press and hold LRN button on RIB for 1/2 second. LED will blink slowly.
4. Trigger a Teach telegram from the Occupancy Sensor per Manufacturer's Instructions.
5. LED on RIB will stay ON for 4 seconds acknowledging telegram reception.
6. Repeat steps 3-5 for additional occupancy sensors.

Optional Modes

Repeater Mode

- Activating Repeater Mode allows relay to repeat signals from other EnOcean devices within range. The relay "hears" the signal and echoes it but will not respond to it unless it has been linked to the transmitting device.
- Relay will allow a signal to be repeated up to two times.

Enabling Repeater Mode

1. Apply power to RIB.
2. Press and hold LRN button on RIB for 1/2 second. LED will flash slowly.
3. Press and hold the CLR button for 3 seconds until LED blinks *twice* indicating Repeater Mode is enabled.

Disabling Repeater Mode

1. Apply power to RIB.
2. Press and hold LRN button on RIB for 1/2 second. LED will flash slowly.
3. Press and hold the CLR button for 3 seconds until LED blinks *three* times indicating Repeater Mode is disabled.

Alarm Mode

- Activating Alarm Mode requires all learned contact switches, such as WDWS-EN3 or RIBWxxxB-EN3, to transmit a CLOSED telegram before relay will activate. Relay will deactivate if any contact switch transmits an OPEN telegram.

Enabling Alarm Mode

1. Apply power to RIB.
2. Press and hold LRN button on RIB for 1/2 second. LED will flash slowly.
3. Press and hold LRN button on RIB for 3 seconds until LED pattern changes to FLASH, FLASH, OFF (2 flashes).
4. Press and hold the CLR button for 3 seconds until LED blinks *twice* indicating Alarm Mode is enabled.

Disabling Alarm Mode

1. Apply power to RIB.
2. Press and hold LRN button on RIB for 1/2 second. LED will flash slowly.
3. Press and hold LRN button on RIB for 3 seconds until LED pattern changes to FLASH, FLASH, OFF (2 flashes).
4. Press and hold the CLR button for 3 seconds until LED blinks *three* times indicating Alarm Mode is disabled.

Delay Mode

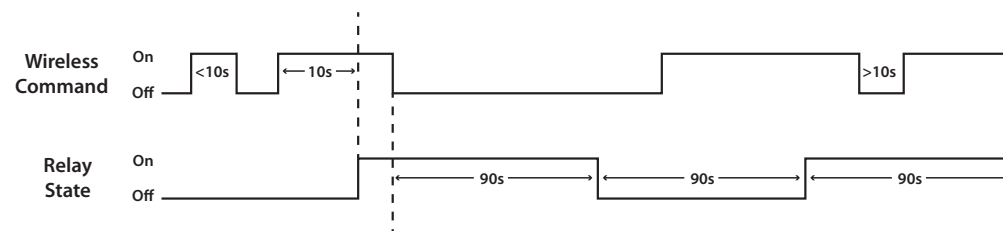

- Typically used with Hotel Room Energy Control (see page 5).
- Activating Delay Mode allows the relay to ignore *temporary* changes in switch states.
- The Delay Mode causes a delay of 10 seconds before relay will turn ON and a delay of 90 seconds before it will turn OFF. It also prevents the relay from activating following a deactivation for 90 seconds (see Figure 4, below).
- The OFF delay allows the load to continue to run while the switch or transmitter is temporarily open. This is helpful when monitoring window and door contacts that may be briefly opened and then closed. If the contact remains open for longer than 90 seconds the relay will deactivate.
- The ON delay prevents the relay from immediately responding to a closed contact.
- The 90 second OFF to ON delay is intended specifically for HVAC units so that they will not short cycle.

Enabling Delay Mode

1. Apply power to RIB.
2. Press and hold LRN button on RIB for 1/2 second. LED will flash slowly.
3. Press and hold LRN button on RIB for 3 seconds until LED pattern changes to FLASH, FLASH, OFF (2 flashes).
4. Press and hold LRN button on RIB for 3 seconds until LED pattern changes again, to FLASH, FLASH, FLASH, OFF (3 flashes).
5. Press and hold the CLR button for 3 seconds until LED blinks *twice* indicating Delay Mode is enabled.

Disabling Delay Mode

1. Apply power to RIB.
2. Press and hold LRN button on RIB for 1/2 second. LED will flash slowly.
3. Press and hold LRN button on RIB for 3 seconds until LED pattern changes to FLASH, FLASH, OFF (2 flashes).
4. Press and hold LRN button on RIB for 3 seconds until LED pattern changes again, to FLASH, FLASH, FLASH, OFF (3 flashes).
5. Press and hold the CLR button for 3 seconds until LED blinks *three* times indicating Delay Mode is disabled.

Clearing ID's from Memory

Global Clear (Reset to default settings)

Clears all linked devices, disables optional modes, and turns relay OFF.

Performing Global Clear

1. Press and hold CLR button on RIB for 3 seconds until LED begins slowly blinking.
 - a. Clear Mode will time out and exit in 30 seconds.

Single Device Clear

- Allows the user to Un-link a single transmitter from RIB receiver.
- Maintains all optional mode settings.

Performing Single Device Clear

1. Repeating the Link procedure for a currently Linked device will Un-link that device.

Energy Saving Applications

RIB with Door/Window Sensor(s) WDWS-EN3

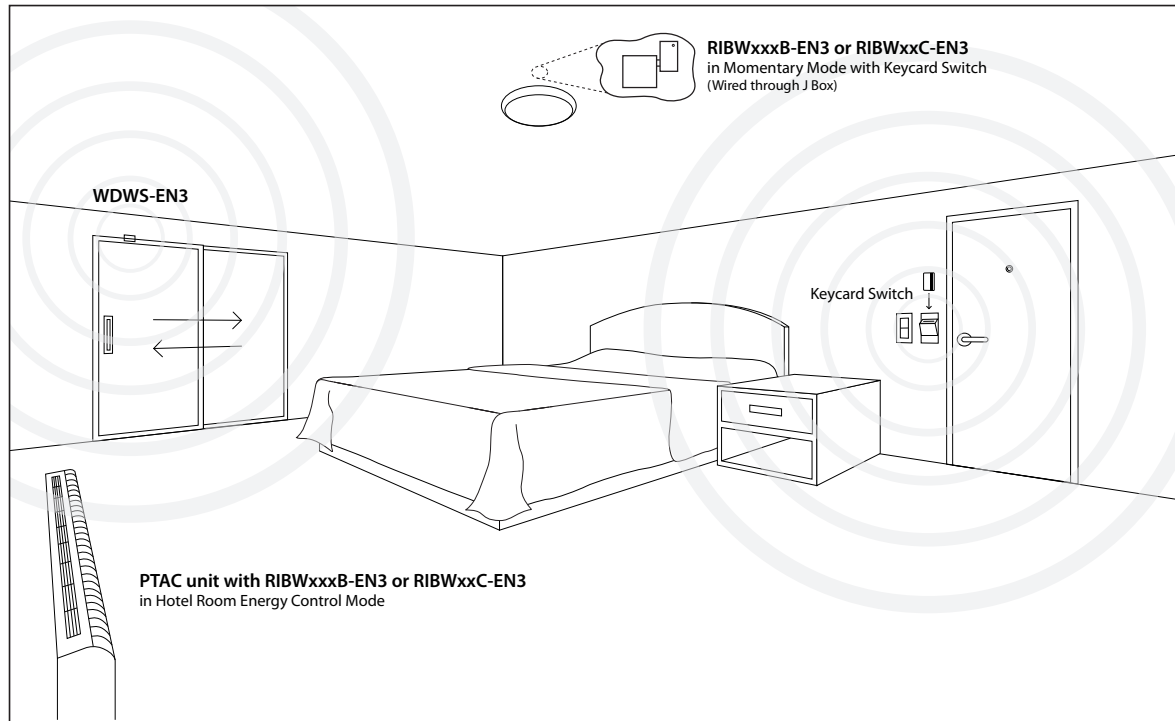

- RIB activates with closed command from WDWS-EN3 and deactivates with open command.
- WDWS-EN3 retransmits contact state every 20-30 minutes.
- Optional modes: Repeater, Alarm, Delay (see pages 4)

WDWS-EN3 Link Procedure

1. Charge the WDWS-EN3 per Instructions provided with unit.
2. Apply power to RIB.
3. Press and hold LRN button on RIB for ½ second. LED will blink slowly.
4. Press and release Link button on WDWS-EN3 to transmit Teach telegram.
5. LED on RIB will stay ON for 4 seconds acknowledging telegram reception.
6. To learn more WDWS-EN3, repeat steps 3-5.

Hotel Room Energy Control RIB with WDWS-EN3 and a Keycard Switch

Consult factory.

Other Common Applications

Unidirectional Control with a BAS System

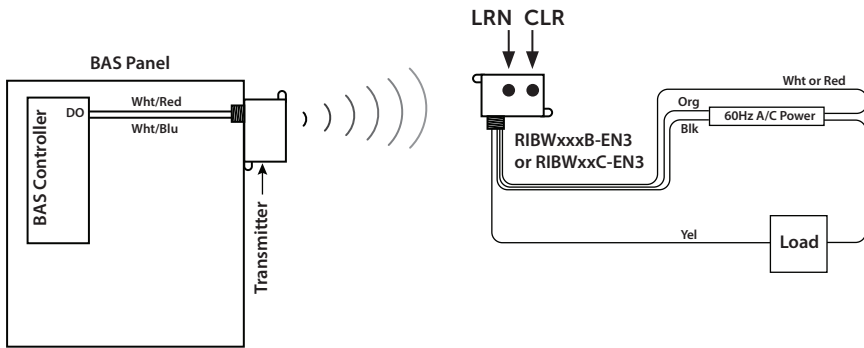

In this application the BAS system dry-contact output controls the transmitter and a RIBWxxxB-EN3 or RIBWxxC-EN3 is the receiver.

Unidirectional Control with a Thermostat

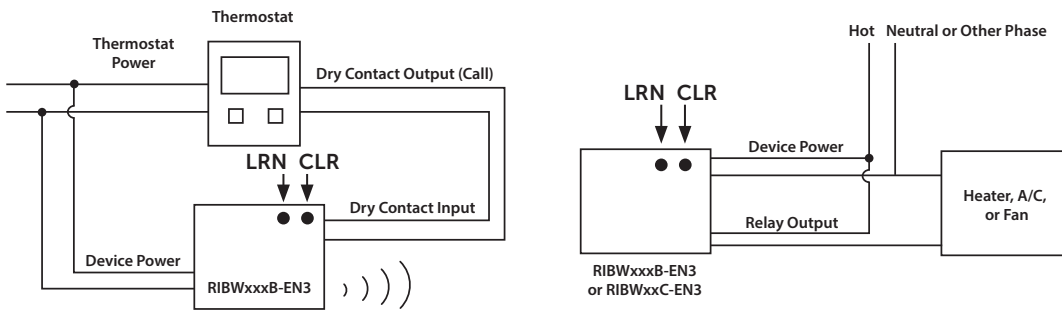

In this application the thermostat dry-contact output controls the transmitter and a RIBWxxxB-EN3 or RIBWxxC-EN3 is the receiver.

Bidirectional Control with a BAS System

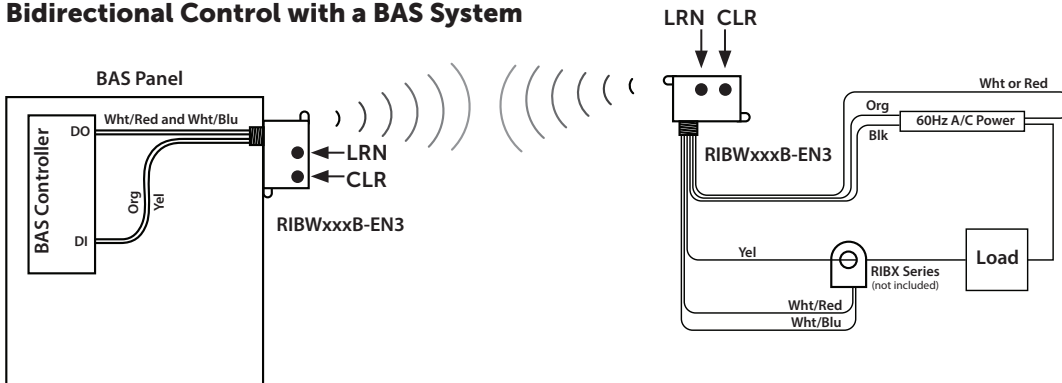

In this application the BAS system dry-contact output controls the transmitter on a RIBWxxxB-EN3. A second RIBWxxxB-EN3 receives the signal and activates its relay. A current switch detects current flow through the load and closes the dry-contact input on the second RIBWxxxB-EN3. The first RIBWxxxB-EN3 receives the transmission and closes its relay. This contact closure to the BAS system lets the controller know the load status.